

MODEL CD280 2-STRAND CHAIN DRAG CONVEYOR

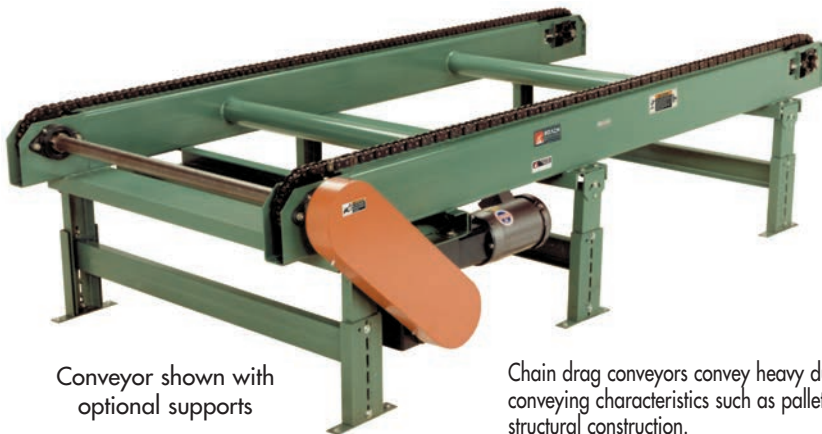

Conveyor shown with optional supports

Chain drag conveyors convey heavy duty unit loads and often are suited for products with unusual conveying characteristics such as pallets or specialty tote pans. Unit shown features OPTIONAL structural construction.

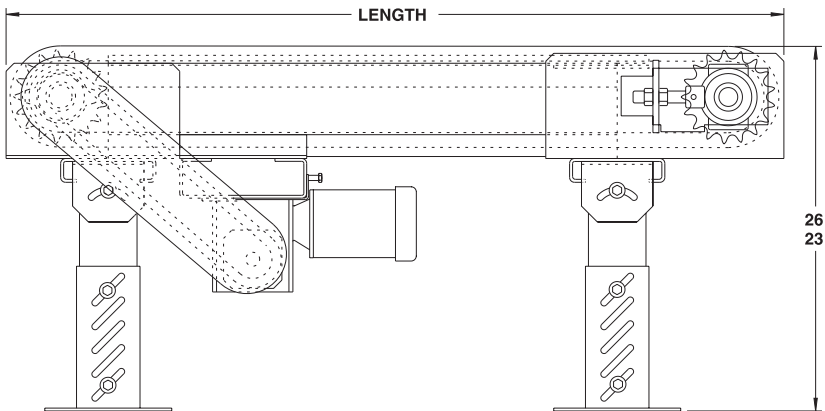
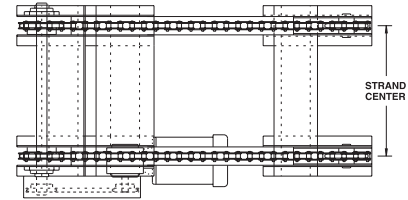

Length	WT. (lbs.)	Length	WT. (lbs.)
3'	377	7'	484
4'	409	8'	516
5'	420	9'	548
6'	452	10'	580

SPECIFICATIONS

FRAME: 7 ga. formed boxed channel.

CARRIER CHAIN: No. 80 (model CD280) or no. 60 (model CD260) riveted roller chain.

WEAR STRIP: UHMW long lasting wear strip, upper and lower.

CHAIN CENTERS: 18"

CHAIN TAKE-UP: Screw type located at tail end.

END DRIVE: Allows one-direction (unit) operation; add optional center drive for reversible application.

CHAIN SPEED: 35 FPM constant.

BEARINGS: Heavy duty, lubricated, ball bearing unit with cast iron housings.

CAPACITY: Unit load not to exceed 3000 lbs.

MOTOR DRIVE: 1/2 HP, 230/460/3, 60 cycle, ODP right angle gear motor.

ELECTRICAL CONTROLS: Optional.

OPTIONAL EQUIPMENT

STRANDS: 3, 4 or more.

CONSTRUCTION: Durable structural frame.

CHAIN CENTER: 12", 24" or as required by application.

FLOOR SUPPORTS: Supports available. See Conveyor Accessories.

CHAIN SPEED: 35-120 FPM, constant speed (specify). Other constant or variable speed available. **NOTE: CAPACITY CHANGES WITH SPEED.**

MOTORS: Available through 3 HP in TEFC, explosion proof, dirty duty, 115/230/1, 575/3, etc.

ELECTRICAL CONTROLS: Manual start/stop push button switch; magnetic starter; photo eye; limit switch; photo relay; others available.

■ 4 week shipment