

MODEL PPF

SERIES 900 FLAT TOP PLASTIC BELT PARTS CONV. W/ FLIGHTS

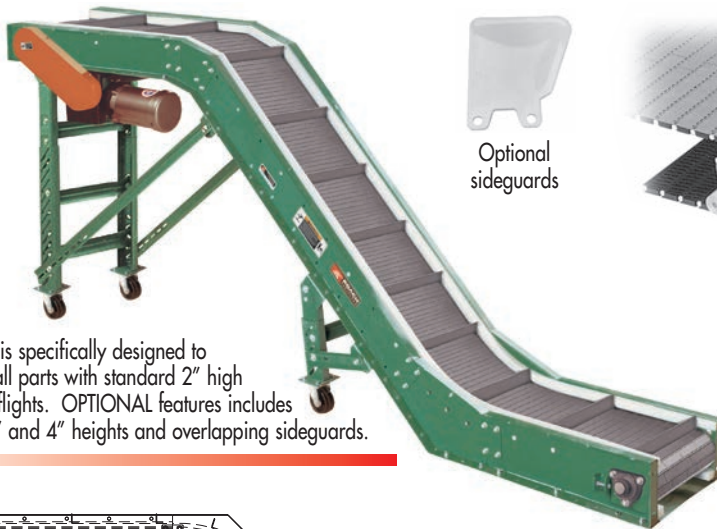

Model PPF is specifically designed to convey small parts with standard 2" high streamline flights. OPTIONAL features includes flights in 1" and 4" heights and overlapping sideguards.

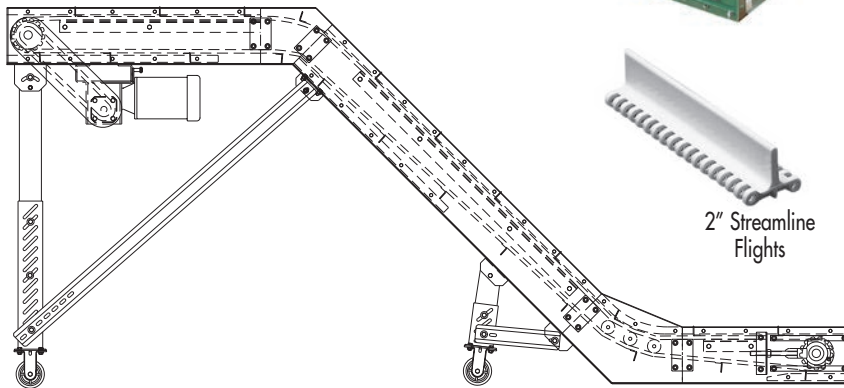
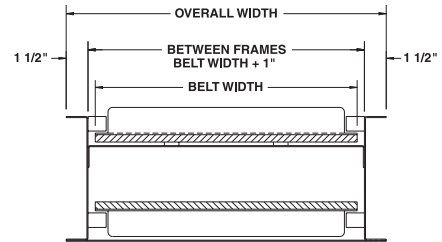
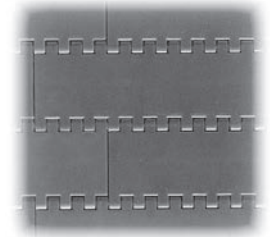
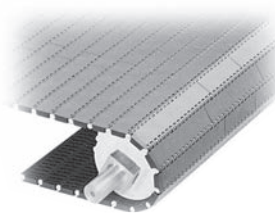

SPECIFICATIONS

BELTING: Series 900 flat top gray polypropylene belt with 2" high streamline flights on 11.9" centers, FDA approved belting.

DRIVE SPROCKETS: 4.1" pitch dia. with 1.5" square bore.

TAIL SPROCKETS: 4.1" pitch dia. with 1.5" square bore.

END DRIVE: Allows one-direction (unit) operation.

TAKE-UP: Catenary type, underneath mounted.

BELT SPEED: 35 FPM, constant.

BEARINGS: Drive shaft bearings are precision, heavy duty, lubricated, ball bearing units with cast iron housings.

BED: 9" deep x 10 ga. enclosed box type construction with UHMW wearstrips mounted to 14 ga. steel belt return pan.

INCLINE: 30, 36 and 45° (specify).

PORTABLE SUPPORT: Adjustable floor supports with 4" dia. casters & bracing.

ROLLER CHAIN: No. 50 chain provided at drive shaft. Chain take-up provided on motor base.

MOTOR DRIVE: 1/3 HP, 230/460/3, 60 cycle, ODP right angle gear motor.

ELECTRICAL CONTROLS: Optional.

PPF AVAILABLE WIDTHS		
BELT WIDTH	BF	OAW
6"	7"	10"
12"	13"	16"
18"	19"	22"
24"	25"	28"

WARNING

Prevent pinch points that exist when belt conveyors are permanently attached to other conveyors or equipment!

OPTIONAL EQUIPMENT

BELTING: Available with 1" and 4" high streamline flights and sideguards for integral guard rail.

DRIVE/TAILO SPROCKETS: 5.8" pitch dia. sprockets with 1.5" square bore; 6.1" & 6.8" pitch dia. sprockets w/ 1.5" or 2.5" square bore.

BELT SPEED: Constant speed 10 to 60 FPM; DC variable speed; AC inverter variable speed. Other constant or variable speeds available. NOTE: CAPACITY CHANGES WITH SPEED.

MOTORS: Available through 1 HP in TEFC, explosion proof, dirty duty, 115/230/1, 575/3, etc.

ELECTRICAL CONTROLS: Magnetic starter; manual starter; momentary start/stop push button station; mounting and pre-wiring for units 12'-0" long and under; limit switch; photo relay; others available.

■ 3 week shipment