

# MODEL 700SBW WIRE MESH BELT CONVEYOR

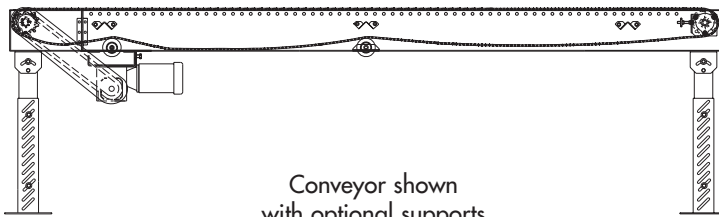

Conveyor shown with optional supports

Roach wire mesh belt conveyors can be used in a variety of conditions to convey hot, cold or oily products in oven, cooling or other special conditions.



Conveyor shown with optional supports

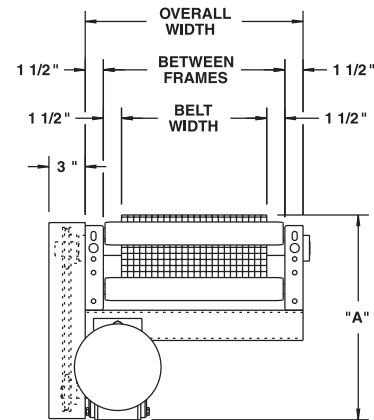

**BELTING:** 1/2" x 1" x 11 ga. clinched edge, galvanized wire mesh belt.

**DRIVE SPROCKETS:** 4" dia. sprocket with 1-3/16" dia. shaft or 8" dia. sprocket with 1-7/16" dia. shaft.

**TAIL SPROCKETS:** 4" dia. sprocket with 1-3/16" dia. shaft.

**END DRIVE:** One-direction unit operation.

**TAKE-UP:** Screw type unit at tail end provides 12" belt take-up.

**RETURN ROLLERS:** 1.9" dia. x 16ga. steel, model 196S, adjustable.

**BED:** 7" x 1-1/2" x 12 ga. formed channel frame with UHMW wear strips.

**BEARINGS:** Drive and tail shaft bearings are precision, heavy duty, lubricated, ball bearing units with cast iron housings.

**BELT SPEED:** 60 FPM, constant.

**MOTOR DRIVE:** 1/3 HP, 230/460/3, 60 cycle, ODP right angle gear motor.

**ROLLER CHAIN:** Drive shaft is driven by No. 50 roller chain for 1-1/2 HP or less and No. 60 chain on larger drives. Chain take-up provided on motor base.

HP @ 60FPM	"A" MAX		"B" MAX	
	4" DRV.	8" DRV.	4" DRV.	8" DRV.
1/3	16-5/8"	16-5/8"	27-3/32"	33-3/32"
1/2	16-5/8"	16-5/8"	27-3/32"	33-3/32"
3/4	17"	17"	27-23/32"	33-23/32"
1	17-1/4"	17-1/4"	28-15/32"	34-15/32"
1-1/2	18-1/8"	18-1/8"	31-3/32"	37-3/32"
2	19"	19"	32-3/32"	38-3/32"

### ⚠ WARNING

Prevent pinch points that exist when belt conveyors are permanently attached to other conveyors or equipment!

### OPTIONAL EQUIPMENT

**BELTING:** High carbon, stainless steel, others available. Consult factory.

**SPEED:** Constant speed 1.5-60 FPM; DC variable speed; AC inverter variable speed. Other constant or variable speeds available. NOTE: CAPACITY CHANGES WITH SPEED.

**MOTORS:** Available through 2 HP in TEFC, explosion proof, dirty duty, 115/230/1, 575/3, etc.

**FLOOR SUPPORTS:** Supports, knee braces, casters, and polytier supports available. See Conveyor Accessories.

### ELECTRICAL CONTROLS:

Magnetic or manual starter; limit switch; others available.

■ 4 week shipment