

# MODEL CT380/CT360 90° 3-STRAND CHAIN TRANSFER

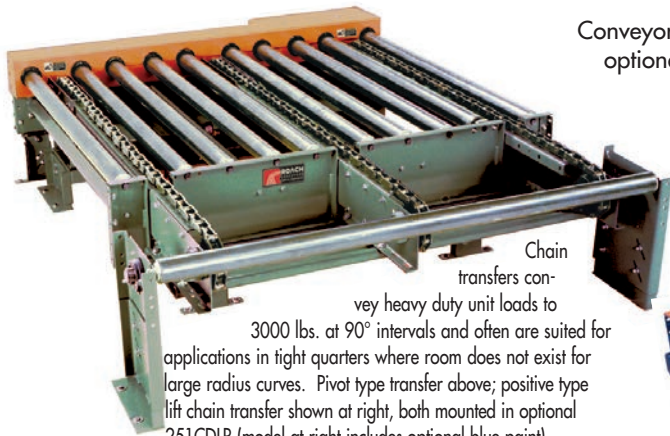

Conveyors shown with optional supports

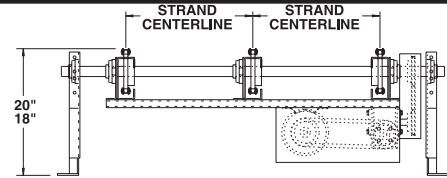

Chain transfers convey heavy duty unit loads to 3000 lbs. at 90° intervals and often are suited for applications in tight quarters where room does not exist for large radius curves. Pivot type transfer above; positive type lift chain transfer shown at right, both mounted in optional 251CDLR (model at right includes optional blue paint).

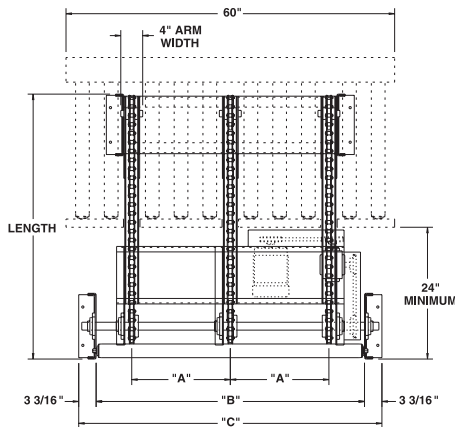

## SPECIFICATIONS

TRANSFER ARM: 7 ga. formed channel.

TRANSFER CHAIN: No. 80 flat side bar (model CT380) or No. 60 flat side bar (model CT360) chain.

STANDARD LENGTHS: 3', 4', 5', 6', 7' and 8' unit lengths.

CHAIN CENTERS: 18"

CHAIN TAKE-UP: Screw Type.

END DRIVE: Allows one-direction (unit) operation; add optional center drive for reversible application.

LIFT: Pivot type.

BEARINGS: Heavy duty, lubricated, ball bearing unit with cast iron housings.

CHAIN SPEED: 35 FPM constant.

MOTOR DRIVE: 1/2 HP, 230/460/3, 60 cycle, ODP right angle gear motor.

CAPACITY: 3000 lbs.

AIR CONTROLS: Air bag(s) with single solenoid valve. (60-80) psi required.

CUTOUTS: Required through conveyor frame transfer mounts in when using end drive; may be required by application for center drive transfers also.

ELECTRICAL CONTROLS: Optional.

LENGTH	MODEL CT360/CT380 WTS. (lbs.)			
	END DRIVE-PIVOT LIFT		CENTER DRIVE-PIVOT LIFT	
	CT360	CT380	CT360	CT380
3'	398	410	433	451
4'	444	460	479	501
5'	490	510	525	551
6'	536	560	571	601
7'	584	612	619	653
8'	631	663	665	704

## OPTIONAL EQUIPMENT

STRANDS: 2, 4 or more.

POSITIVE LIFT: Allows reversible drive and decreased overall length.

FRL: Filter, regulator, lubricator with 3/8" ports.

FLOOR SUPPORTS: See Conveyor Accessories for various elevations and types.

CHAIN CENTER: 12", 24" or as required by application.

CHAIN SPEED: 35-120 FPM, constant speed (specify). Other constant or variable speed available. NOTE: CAPACITY CHANGES WITH SPEED.

MOTORS: Available through 2 HP in TEFC, explosion proof, dirty duty, 115/230/1, 575/3, etc.

ELECTRICAL CONTROLS: Optional.

"A"	"B"	"C"
12"	37"	43-3/8"
18"	49"	55-3/8"
24"	61"	67-3/8"

■ 4 week shipment