

MODEL 700PB SERIES 900 FLAT FRICTION TOP PLASTIC BELT CONVEYOR

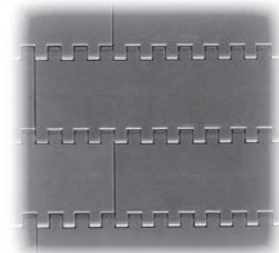

Conveyor shown with optional supports

Ideal for general goods transportation in applications such as packing, testing, inspecting and various assembly line operations. Belt tracking problems are eliminated with model 700PB.

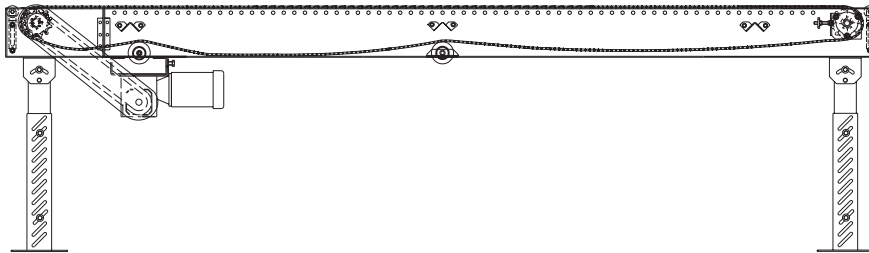
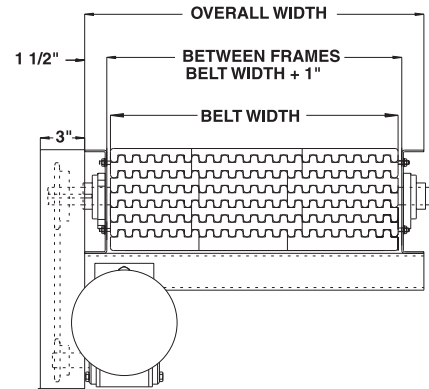

SPECIFICATIONS

BELTING: Series 900 flat top gray polypropylene belt, FDA approved belt.

DRIVE SPROCKETS: 4.1" pitch dia. with 1.5" square bore. Available with OPTIONAL 6.1" or 6.8" pitch dia. sprockets with 1.5" or 2.5" square bore.

TAIL SPROCKETS: 4.1" pitch dia. with 1.5" square bore. Available with OPTIONAL 6.1" or 6.8" pitch dia. sprockets with 1.5" or 2.5" square bore.

BEARINGS: Drive and tail shaft bearings are precision, heavy duty, lubricated, ball bearing units with cast iron housings.

END DRIVE: Allows one-direction (unit) operation.

BED: 7" x 1-1/2" x 10 ga. channel frame with open style bed construction and UHMW wearstrips mounted to longitudinal channels.

TAKE-UP: Catenary type located at discharge end.

RETURN ROLLERS: 1.9" dia. x 16 ga. steel, model 196S, adjustable with rubber sleeves.

BELT SPEED: 60 FPM, constant.

FLOOR SUPPORTS: See Conveyor Accessories.

MOTOR DRIVE: 1/3 HP, 230/460/3, 60 cycle, ODP right angle gear motor.

ROLLER CHAIN: Drive shaft is driven by No. 50 roller chain for 1-1/2 HP or less and No. 60 chain on larger drives. Chain take-up provided on motor base.

ELECTRICAL CONTROLS: Optional.

WARNING

Prevent pinch points that exist when belt conveyors are permanently attached to other conveyors or equipment!

■ 3 week shipment