

ALL STEEL CONSTRUCTION. THE STRONGEST CONVEYORS IN THE WORLD.

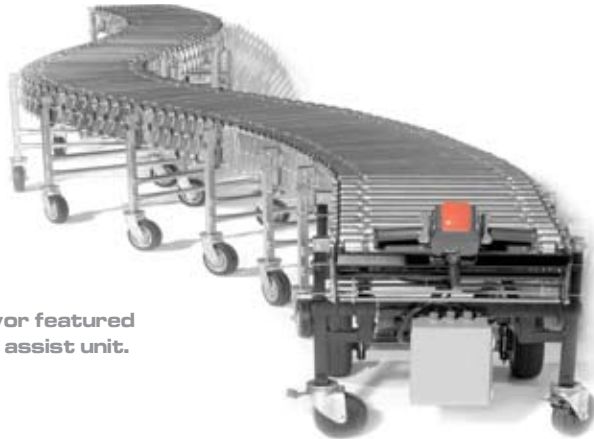

SMART DESIGNS COME FROM SMART SOLUTIONS.



Power roller conveyor featured with optional power assist unit.

NESTAFLEX®
FLEXIBLE CONVEYORS

1.6



ALL POWER ROLLER CONVEYOR

The NESTAFLEX 1.6 POWER ELITE all roller power conveyor has a capacity of 100 pounds per lineal foot (level surface). It operates on DC drive motors with a 120VAC converter, delivering variable speeds of 0-120 feet per minute PLUS standard reversible action.

The POWER ELITE with its innovative design, requires less storage space when fully retracted, and with its ALL-BOLTED construction and durable design, this conveyor is the smart solution for distribution centers where there is high volume cross docking, loading and unloading applications. With features such as built in impact conveyor, electronic indexing, zero pressure accumulation, and power assist, the POWER ELITE is the next step in automating your application.

The 1.6 is also a smart solution in packaging and manufacturing applications allowing greater product control and maximizing worker efficiency. Like all NESTAFLEX conveyors, the 1.6 POWER ELITE is portable, expandable and can be configured to meet specific material handling needs. **The all roller power conveyor is also available as the 1.9 POWER PLUS HD using 1.9 diameter steel rollers.**

CONVEYOR OPTIONS



Impact Conveyor



Power Truck Loader with Guide Track and Herringbone transition



Zero Pressure Accumulation



Power Assist Unit

ALL STEEL CONSTRUCTION. THE STRONGEST CONVEYORS IN THE WORLD.



SMART DESIGNS COME FROM SMART SOLUTIONS.

SPECIFICATIONS

Model Length	1.6 Power Elite 18" Widths	1.6 Power Elite 24" Widths	1.6 Power Elite 30" Widths	1.6 Roller Contracted Length	1.9 Roller Contracted Length	3" Axle Centers Extended Length	4" Axle Centers Extended Length	5 1/4" Axle Centers Extended Length
12	pRL18012S1201.6	pRL24012S1201.6	pRL30012S1201.6	4' 2"	5' 2"	6' 11"	9' 2"	12' 0"
16	pRL18016S1201.6	pRL24016S1201.6	pRL30016S1201.6	5' 4"	6' 7"	8' 11"	11' 10"	15' 5"
19	pRL18019S1201.6	pRL24019S1201.6	pRL30019S1201.6	6' 9"	8' 4"	11' 2"	14' 9"	19' 3"
23	pRL18023S1201.6	pRL24023S1201.6	pRL30023S1201.6	7' 11"	9' 10"	13' 2"	17' 5"	22' 9"
26	pRL18026S1201.6	pRL24026S1201.6	pRL30026S1201.6	9' 2"	11' 3"	15' 2"	20' 1"	26' 3"
30	pRL18030S1201.6	pRL24030S1201.6	pRL30030S1201.6	10' 4"	12' 8"	17' 2"	22' 9"	29' 9"
33	pRL18033S1201.6	pRL24033S1201.6	pRL30033S1201.6	11' 9"	14' 5"	19' 5"	25' 8"	33' 6"
37	pRL18037S1201.6	pRL24037S1201.6	pRL30037S1201.6	12' 11"	15' 10"	21' 5"	28' 4"	37' 0"
40	pRL18040S1201.6	pRL24040S1201.6	pRL30040S1201.6	14' 1"	17' 4"	23' 5"	31' 0"	40' 6"
51	pRL18051S1201.6	pRL24051S1201.6	pRL30051S1201.6	16' 9"	20' 6"	27' 8"	36' 7"	47' 9"
54	pRL18054S1201.6	pRL24054S1201.6	pRL30054S1201.6	17' 11"	21' 11"	29' 8"	39' 3"	51' 3"
58	pRL18058S1201.6	pRL24058S1201.6	pRL30058S1201.6	19' 1"	23' 5"	31' 8"	41' 11"	54' 9"
61	pRL18061S1201.6	pRL24061S1201.6	pRL30061S1201.6	20' 4"	24' 10"	33' 8"	44' 7"	58' 3"
65	pRL18065S1201.6	pRL24065S1201.6	pRL30065S1201.6	21' 9"	26' 7"	35' 11"	47' 6"	62' 0"
68	pRL18068S1201.6	pRL24068S1201.6	pRL30068S1201.6	22' 11"	28' 0"	37' 11"	50' 2"	65' 6"
72	pRL18072S1201.6	pRL24072S1201.6	pRL30072S1201.6	24' 4"	29' 9"	40' 2"	53' 1"	69' 3"
75	pRL18075S1201.6	pRL24075S1201.6	pRL30075S1201.6	25' 6"	31' 2"	42' 2"	55' 9"	72' 9"
				26' 11"	32' 11"	44' 5"	58' 8"	76' 6"

NESTAFLEX 1.6 STANDARD FEATURES AND OPTIONS

NESTAFLEX
FLEXIBLE CONVEYORS

1.6

ALL POWER ROLLER CONVEYOR
Other Options Available

We encourage you to take advantage of our free application analysis to determine the operational efficiencies that can be gained from the Nestaflex 1.6 and the flexible material handling—smart solutions team.

CONSTRUCTION

All-steel BOLTED construction.

CONVEYOR FORMATS

Available in 18", 24" and 30" widths. Lengths can be tailored to your specific application.

CAPACITY

100 pounds per linear foot—level capacity. On 3 degree incline—50 pounds per linear foot.

LEGS

Legs are made from heavy-duty steel tubing and have welded, double horizontal cross braces.

SIDE LINKS

1.72" wide side links are made from steel and feature all bolted construction.

HEAVY DUTY CASTERS

Standard 6" x 2" swivel casters. Optional 8" x 2" casters available. Both have steel foot brake that locks wheel and swivel simultaneously.

AXLES

Standard axle centers are 5 1/4". Optional 4" and 3" axle centers are available to convey small cartons.

PACKAGE STOP

Electronic/mechanical package stop is optional.

HEAVY-DUTY ROLLERS

1.6" diameter rollers (1.9" on the 1.9 model) are made from 16-gauge steel and have precision bearings and a 1/4" diameter polyurethane drive belt.

WARRANTY

One-year factory warranty.