

# MODEL 700SB MEDIUM DUTY SLIDER BED BELT CONVEYOR

24 HOUR SHIPMENTS INCLUDE ALL 1-FOOT INCREMENTS 5'-0" TO 100'-0"



Conveyor shown with optional supports

Slider bed belt conveyors remain the most popular of all powered conveyors, providing an economical means of transporting goods for packing, testing, inspecting and various assembly line operations

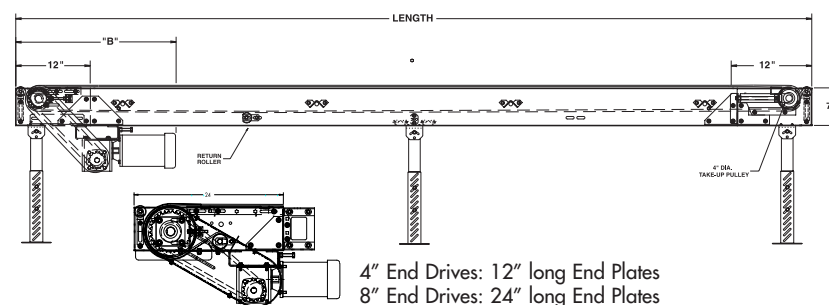
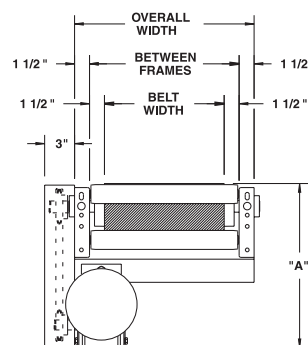

4" End Drives: 12" long End Plates  
8" End Drives: 24" long End Plates

HP@ 60 FPM	"A" MAX		"B" MAX	
	4" DRV.	8" DRV.	4" DRV.	8" DRV.
1/3	16-5/8"	16-5/8"	27-3/32"	33-3/32"
1/2	16-5/8"	16-5/8"	27-3/32"	33-3/32"
3/4	17"	17"	27-23/32"	33-23/32"
1	17-1/4"	17-1/4"	28-15/32"	34-15/32"
1-1/2	18-1/8"	18-1/8"	31-3/32"	37-3/32"
2	19"	19"	32-3/32"	38-3/32"

## SPECIFICATIONS

**BELTING:** PVC-120 black.

**DRIVE PULLEY:** 4" dia. with 1-3/16" dia. shaft or 8" dia. with 1-7/16" dia. shaft, both machine crowned and fully lagged.

**TAIL PULLEY:** 4" dia., machine crowned, with 1-3/16" dia. shaft.

**END DRIVE:** Allows one-direction (unit) operation; add optional center drive for reversible application.

**TAKE-UP:** Screw type unit at tail pulley provides 12" belt take-up.

**SAFETY POP-OUT ROLLER:** Standard on both ends, 1.9" dia. x 16 ga. steel roller, model 196S.

**BEARINGS:** All pulley bearings are precision, heavy duty, lubricated, ball bearing units with cast iron housings.

**BED:** 7" x 1-1/2" x 12 ga. channel frame with 14 ga. slider bed.

**BELT SPEED:** 60 FPM, constant.

**MOTOR DRIVE:** 1/3 HP, 230/460/3, 60 cycle, ODP right angle gear motor.

**ROLLER CHAIN:** Drive pulley is driven by No. 50 roller chain for 1-1/2 HP or less and No. 60 chain on larger drives. Chain take-up provided on motor base.

**RETURN ROLLERS:** 1.9" dia. x 16 ga. steel, model 196S, adjustable.

**ELECTRICAL CONTROLS:** Optional.

## WARNING

Prevent pinch points that exist when belt conveyors are permanently attached to other conveyors or equipment!

## SPECIFICATION TABLE

50'-0" lengths and under are equipped with 4" dia. drive pulley; over 50'-0" includes 8" dia. drive pulley

■ 24 hour shipment ■ 2 week shipment

CONVEYOR LENGTH	10'	20'	30'	40'	50'	60'	70'	80'	90'	100'	DEDUCT	
BELT	UNIT WEIGHTS (lbs.)										PER FOOT	
6"	9"	260	389	518	647	776	904	1033	1162	1291	1420	13
12"	15"	315	482	650	818	986	1154	1322	1490	1657	1825	17
18"	21"	369	576	783	990	1196	1403	1610	1817	2024	2230	21
24"	27"	424	670	915	1161	1407	1653	1898	2144	2390	2636	25
30"	33"	478	763	1048	1333	1617	1902	2187	2471	2756	3041	29
36"	39"	533	857	1180	1504	1828	2151	2475	2799	3122	3446	32

## OPTIONAL EQUIPMENT

**BELTING:** Black PVC ruff-top; 3-ply brown neoprene ruff-top; PVC-120 white food grade COS; PVC-150 black COS; 3-ply CN 40 urethane cover. Consult factory for other belting.

**CENTER DRIVE:** Reversible drive with integral belt take-up of 24". Specify location. Center drive option available on units 6'-0" long and above.

**SIDE MOUNTED END DRIVE:** Provides minimum conveyor height of 10" TOB (4" dia. drive pulley); 12" TOB (8" dia. drive pulley).

**OVERHEAD END DRIVE:** Provides minimum conveyor height of 8" TOB (4" dia. drive pulley); 10" TOB (8" dia. drive pulley).

**NOSE-OVER:** Provides smooth transition from incline to horizontal position. Single nose-over adjusts 0-20°; double nose-over adjusts 0-35°. Feeders also available. See Power Accessories.

**AUXILIARY TAKE-UP:** Provides 24" of belt take-up. Specify location. See Power Accessories.

**SIDE TABLES:** Available in 9", 15" and 21" widths (14 ga.) one or both sides. See Power Accessories.

**UNDERTRUSSED BED:** Available to provide clearance underneath unit at bed joint locations. Specify location for undertrussing and desired clearance underneath unit. Consult factory.

**CEILING HANGERS:** 5/8" dia. threaded rod with hardware to attach rods to conveyor. Provides 6' clearance between ceiling and TOB (furnished in place of floor supports). See Conveyor Accessories.

**BELT SPEED:** Constant speed 10-120 FPM; DC variable speed; AC inverter variable speed. Other constant or variable speeds available.

**NOTE:** CAPACITY CHANGES WITH SPEED.

**FLOOR SUPPORTS:** Supports, knee braces, casters and polytier supports available. See Conveyor Accessories.

**GUARD RAILS:** 1-3/4" x 1" formed channel (model GC), adjusts horizontally to 10" wider than belt and vertically to 6" above belt; formed steel fixed (model FSG in 2", 4", 6", 8", 12", and 18" heights; fixed channel (model FC); 1-1/2" angle (model GA1-1/2). See Conveyor Accessories.

**MOTORS:** Available through 3 HP in TEFC, explosion proof, dirty duty, brake motor, 115/230/1, 575/3, etc.

**ELECTRICAL CONTROLS:** Magnetic starter (one direction or reversible); One direction manual starter; Momentary start/stop push button station; Forward/reversing /stop push button station. Mounting and pre-wiring for units up to 12' long.



OPTIONAL DC VARIABLE SPEED CONTROLLER



OPTIONAL CENTER DRIVE