

MODEL SZ796LSZ W/PHOTOEYE CONTROLLED SMART ZONE® LINE SHAFT ZERO PRESSURE ACCUMULATOR

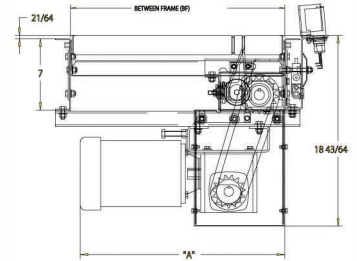

Conveyor shown with optional supports

SZ796LSZ SMART ZONE® quietly accumulates a wide variety of product sizes and features NO minimum weight limitations. SMART ZONE® eliminates sensor rollers and replaces with photo electric sensors to accumulate products with previously difficult minimal weight restrictions. This zero pressure line shaft driven accumulator is ideal for numerous light to medium duty applications since curves, spurs and other modules may be driven by a single drive.



SMART ZONE:
Retroreflective photo eyes include a 24V DC power supply operated by a 110V AC input.

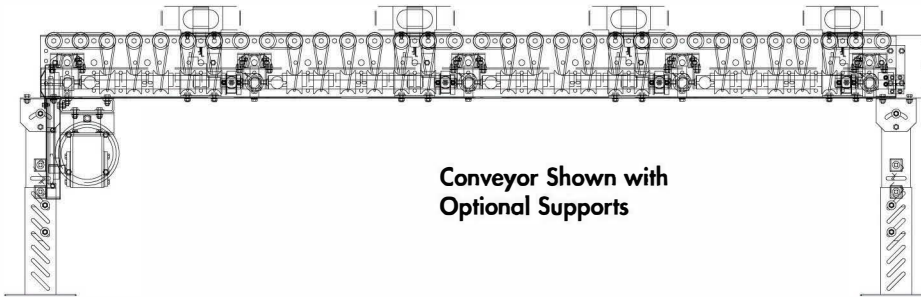

Conveyor Shown with
Optional Supports

HP@ 60 FPM	"A" MAX
1/3, 1/2	21"
3/4, 1	22"
1-1/2, 2	23"

SPECIFICATIONS

TREAD ROLLERS: 1.9" dia. x 16 ga. steel, model 196S grooved.

DRIVE BELT: 3/16" dia., polyurethane belts. Nominal 15 lbs. per roller drive.

DRIVE SHAFT: 1" dia. C1018 cold rolled steel shaft.

COUPLINGS: Couplings located both ends (type "A"), one end only (type "B" or "C") or none (type "D"). See 'line shaft coupling chart' opposite page, and specify.

CENTER DRIVE: Located approximately 16-1/2" from end of bed section on 4" RC; 18" on 3" and 6" RC.

SPEED: 60 FPM, constant.

ACCUMULATION: Zone singulation operation; 2'-0" zone length; zones are pneumatically actuated using photo electric sensors.

BEARINGS: All bearings are precision, lubricated, ball bearing units with composite housings.

BED: 7" x 1-1/2" x 12 ga. formed steel channel frame. Bed sections attached with splice plates and floor supports.

FRL: Unit is provided with filter, regulator, lubricator with 1/4" ports.

PNEUMATIC ACTUATION: Maximum air line pressure should not exceed 30 PSI.

MOTOR DRIVE: 1/3 HP, 230/460/3, 60 cycle, ODP right angle gear motor.

ROLLER CHAIN: Drive shaft is driven by No. 50 chain. Chain take-up provided on motor base.

CAPACITY: See technical section for load capacity rating.

*Roach Conveyors- Thomas Conveyor and Equipment
28 Hillside Avenue- Hillside- IL- 60162- www.tceconveyors.com*

SPECIFICATION TABLE

■ 3 week shipment

CONVEYOR LENGTH		10'	20'	30'	40'	50'	60'	70'	80'	90'	100'	Deduct
BF	OAW	UNIT WEIGHTS (lbs.) with 3" Roller Centers (For other centers, deduct weights below)										Per Foot
15"	18"	551	928	1306	1683	2061	2438	2816	3193	3571	3948	38
19"	21"	589	1003	1417	1831	2244	2658	3072	3486	3900	4313	41
21"	24"	612	1049	1486	1923	2360	2797	3234	3671	4108	4545	44
25"	28"	646	1130	1613	2096	2580	3063	3546	4029	4513	4996	48
27"	30"	672	1178	1684	2191	2697	3203	3710	4216	4722	5229	51
33"	36"	724	1300	1876	2452	3027	3603	4179	4755	5331	5906	58
39"	42"	788	1504	2079	2724	3369	4015	4660	5305	5950	6595	72

Deduct the following weights (lbs.) for other than 3" centers

Tread Roller Centers	15" BF		19" BF		21" BF		25" BF		27" BF		33" BF		39" BF	
	Per 5'	Per 10'	Per 5'	Per 10'	Per 5'	Per 10'	Per 5'	Per 10'	Per 5'	Per 10'	Per 5'	Per 10'	Per 5'	Per 10'
4"	-14	-28	-17	-34	-19	-37	-21	-42	-23	-45	-27	-53	-31	-62
6"	-18		-34	-68	-37			-84	-45	-90	-53	-106	-62	-124

OPTIONAL EQUIPMENT

SIDE MOUNTED DRIVE: Provides overall conveyor height of 10".

ACCUMULATION ZONES: 18" and 30" long zones available, depending on roller centers.

FLOOR SUPPORTS: Supports, knee braces, casters and polytier supports available. See Conveyor Accessories.

CEILING HANGERS: 5/8" dia. threaded rod with hardware to attach rods to conveyor. Provides 6' clearance between ceiling and TOR (furnished in place of floor supports). See Conveyor Accessories.

CONVEYOR SPEED: Constant speed 15-120 FPM; DC variable speed; AC inverter variable speed. MINIMUM operating speed for line shaft conveyor is 30 FPM.

SLUG RELEASE: Products may be slug released rather than individual product release in normal zone singulation; accumulation mode will not be disturbed when slug release option utilized.

GALVANIZED ROLLERS: Tread rollers available in galvanized steel, model 196G grooved.

MOTORS: Available through 2 HP in TEFC, explosion proof, dirty duty, 115/230/1, 575/3, etc.

DEFUSED SMARTZONE: Photoeyes mounted below tread rollers.

LINE SHAFT COUPLING CHART

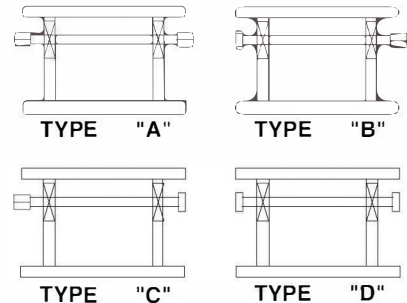

PHOTO SENSOR MOUNT



LINE SHAFT BEARING HOUSING