

MODEL SZ196ZPA SMART ZONE® MEDIUM DUTY ZERO PRESSURE LIVE ROLLER ACCUMULATOR



Conveyor shown with optional supports

Roach SZ196ZPA SMART ZONE® safely accumulates packages with zero back pressure utilizing zone singulation operation. Loads up to 125 lbs./ft. may be effectively handled with its unique design. This conveyor features NO minimum weight limitations. Roach SMART ZONE® replaces sensor rollers with photo electric sensors to accumulate products with previously difficult minimal weight restrictions and is easy to install.

SMART ZONE:

Retroflective photo eyes include a 24V DC power supply operated by a 110V AC input.

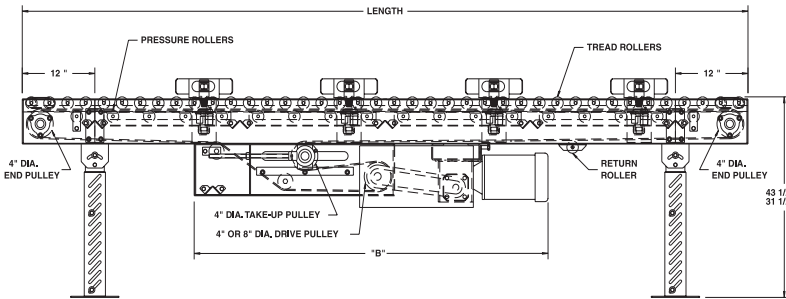
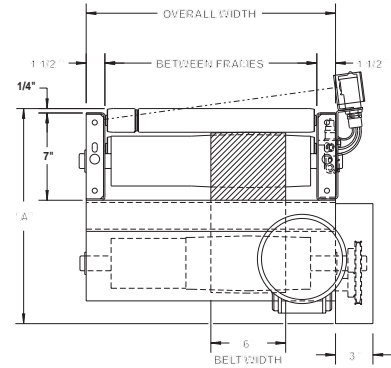

HP@ 60 FPM	"A" MAX		"B" MAX	
	4" DRV.	8" DRV.	4" DRV.	8" DRV.
1/3	16-5/8"	17-5/8"	58-5/32"	58-5/32"
1/2	16-5/8"	17-5/8"	58-5/32"	58-5/32"
3/4	17"	17-5/8"	58-25/32"	58-25/32"
1	17-1/4"	17-5/8"	59-17/32"	59-17/32"
1-1/2	18-1/8"	18-1/8"	61-21/32"	61-21/32"
2	19"	19"	62-21/32"	62-21/32"

SPECIFICATIONS

TREAD ROLLERS: 1.9" dia. x 16 ga. steel, model 196S.

PRESSURE ROLLERS: 1.9" dia. x 16 ga. steel, model 196S; 8" BF with 6" wide belt.

BELTING: 6" wide black PVC-120 COS.

DRIVE PULLEY: 4" dia. with 1-3/16" dia. shaft or 8" dia. with 1-7/16" dia. shaft, both crowned and fully lagged.

END PULLEY: 4" dia., crowned, with 1-3/16" dia. shaft.

RETURN ROLLERS: 1.9" dia. x 16 ga. steel, model 196S, adjustable.

BEARINGS: All pulley bearings are precision, heavy duty, lubricated, ball bearing units with cast iron housings.

SPEED: 60 FPM, constant.

ACCUMULATION: Zone singulation operation; 2'-0" long zones. 1'-0" of live roller over end plates at each end of conveyor remains "live" during operation (# of zones x zone length + 2' = overall conveyor length). Zones are pneumatically actuated using photo electric sensors.

BED: 7" x 1-1/2" x 12 ga. channel frame slotted for tread rollers to pop-out. When unit is installed at 7'-0" elevation or higher, rollers must be retained in conveyor frame. Specify desired elevation. Bed sections attached with couplings and floor supports.

FRL: Unit is provided with filter, 1 regulator, lubricator with 1/4" ports.

PNEUMATIC ACTUATION: Maximum air line pressure should not exceed 30 PSI.

SQUARING RODS: Adjustable rods on underside of bed allow frame to be squared for improved belt tracking and are standard on all units over 30'.

MOTOR DRIVE: 1/3 HP, 230/460/3, 60 cycle, ODP right angle gear motor.

ROLLER CHAIN: Drive pulley is driven by No. 50 roller chain for 1-1/2 HP or less and No. 60 chain on larger drives. Chain take-up provided on motor base.



WARNING

Pop-out rollers should be retained in frame if unit is elevated to 7'-0" and above.
www.tceconveyors.com (708) 449-2100

SPECIFICATION TABLE

50'-0" lengths and under are equipped with 4" dia. drive pulley; over 50'-0" includes 8" dia. drive pulley

■ 3 week shipment

CONVEYOR LENGTH			10'	20'	30'	40'	50'	60'	70'	80'	90'	100'	Deduct
BF	OAW	BELT	UNIT WEIGHTS (lbs.) with 3" Roller Centers (For other centers, deduct weights below)										Per Foot
15"	18"	6"	520	824	1127	1431	1734	2038	2341	2645	2948	3252	30
19"	22"	6"	576	912	1248	1584	1920	2255	2591	2927	3263	3599	34
21"	24"	6"	605	956	1308	1660	2012	2364	2716	3068	3420	3772	35
25"	28"	6"	661	1045	1429	1813	2198	2582	2966	3350	3734	4119	38
27"	30"	6"	689	1089	1490	1890	2290	2691	3091	3491	3892	4292	40
33"	36"	6"	774	1222	1671	2120	2568	3017	3466	3915	4363	4812	45
39"	42"	6"	858	1355	1852	2349	2846	3344	3841	4338	4835	5332	50

Deduct the following weights (lbs.) for other than 3" centers

Tread Roller Centers	15" BF		19" BF		21" BF		25" BF		27" BF		33" BF		39" BF	
	Per 5'	Per 10'	Per 5'	Per 10'	Per 5'	Per 10'	Per 5'	Per 10'	Per 5'	Per 10'	Per 5'	Per 10'	Per 5'	Per 10'
4"	-23	-45	-28	-55	-30	-60	-35	-69	-37	-75	-45	-90	-53	-105
6"	-45	-90	-54	-108	-60	-120	-69	-138	-75	-150	-90	-180	-105	-210

OPTIONAL EQUIPMENT

ACCUMULATION: 30" and 60" zones available in 3" and 6" roller centers; 40" and 60" zones available in 4" roller centers.

SLUG RELEASE: Products may be slug released rather than individual product release in normal zone singulation; accumulation mode will not be disturbed when slug release option utilized.

BELTING: 6" wide black PVC-150; 12" wide PVC-120.

END DRIVE: Mounted underneath conveyor. Minimum possible height is 20" TOR for underneath mounted end drive. Belt take-up required for end drive (if substituting end drive for center drive).

AUXILIARY TAKE-UP: Provides 24" of belt take-up; specify location. See Power Accessories.

FLOOR SUPPORTS: Supports, knee braces, casters and polytier supports available. See Conveyor Accessories.

CEILING HANGERS: 5/8" dia. threaded rod with hardware to attach rods to conveyor. Provides 6' clearance between ceiling and TOR (furnished in place of floor supports). See Conveyor Accessories.

GALVANIZED ROLLERS: Both tread and pressure rollers available in galvanized steel, model 196G. Specify tread only or both tread and pressure rollers.

192S TREAD ROLLERS: 1.9" dia. x 12 ga. steel tread rollers, model 192S, available in model SZ192ZPA SMART ZONE®.

SPEED: Constant speed 15-120 FPM; DC variable speed; AC inverter variable speed. Other constant or variable speeds available. **NOTE: CAPACITY CHANGES WITH SPEED.**

MOTORS: Available through 3 HP in TEFC, explosion proof, dirty duty, brake motor, 115/230/1, 575/3, etc.

DEFUSED SMARTZONE: Photoeyes mounted below tread rollers.



PHOTO SENSOR MOUNT

