

MODEL 192CDLRC MEDIUM DUTY CHAIN DRIVEN LIVE ROLLER CURVE



Conveyor shown with optional supports

SPECIFY MODEL NUMBER PER EXAMPLE
192CDLRC-27-45-L
192CDLRC-(between frames)-(degree)-(left or right)

Roach 192CDLRC is a medium duty chain driven live roller curve, designed to transport medium duty loads such as castings or drums. **NOTE:** When conveying medium duty pallet loads, use model 254TCDLRC, opposite page, to maintain product orientation.

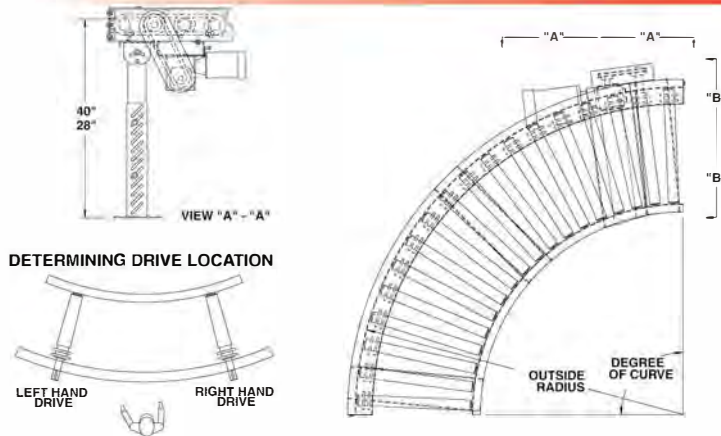
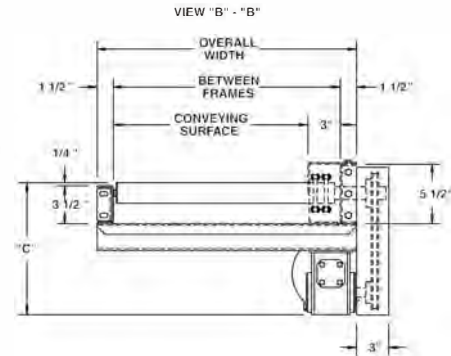

UNIT			90°		45°	
BF	CONV. SURFACE	OUTSIDE RADIUS	QTY. RLRS.	WT. (lbs.)	QTY. RLRS.	WT. (lbs.)
15"	12"	4'-10-3/4"	18	339	9	265
21"	18"	4'-10-3/4"	18	374	9	277
27"	24"	4'-10-3/4"	18	409	9	292
33"	30"	8'-15/16"	30	543	15	313
39"	36"	8'-15/16"	30	586	15	337
45"	42"	8'-15/16"	30	633	15	364
51"	48"	8'-15/16"	30	681	15	391

CHAIN DRIVEN LIVE ROLLERS

SPECIFICATIONS

TREAD ROLLERS: 1.9" dia. x 12 ga. steel, model 192S with sprockets.*

CHAIN DRIVE: Roller to roller with No. 40 circular roller chain.

END DRIVE: Reversible drive either side mounted or underside (specify). Main drive roller is supported by precision, heavy duty, lubricated, ball bearing units.

CHAIN GUARD: Chain drive is enclosed, top and bottom, along entire length of conveyor.

BED: 5-1/2" x 1-1/2" x 10 ga. and 3-1/2" x 1-1/2" x 10 ga. formed steel channel frame.

BEARINGS: Removable type, heavy duty bearings, zinc plated, grease packed, labyrinth sealed.

MOTOR DRIVE: 1/3 HP, 230/460/3, 60 cycle, ODP right angle gear motor.

SPEED: 45 FPM, constant.

DRIVE LOCATION: Drive located on outside of curve. Specify right hand drive or left hand drive (drive hand determined with reference point located at outside of curve).

ROLLER CENTERS: 5" RC measured at outside radius of curve.

ELECTRICAL CONTROLS: Optional.

HP @ 45FPM	"C"
1/3, 1/2	13-1/8"
3/4	13-1/2"
1	13-3/4"
1-1/2	14-5/8"
2	15-1/2"

OPTIONAL EQUIPMENT

SPEED: Constant speed 1.5-60 FPM; DC variable speed; AC inverter variable speed. Other constant or variable speeds available.

NOTE: CAPACITY CHANGES WITH SPEED. 100 FPM MAX. WITH ROLLER-TO-ROLLER CHAIN DRIVE.

MOTORS: Available through 3 HP in TEFC, explosion proof, dirty duty, 115/230/1, 575/3, etc.

FLOOR SUPPORTS: Supports, knee braces, casters, ceiling hangers and polytier supports available. See Conveyor Accessories.

ELECTRICAL CONTROLS: Magnetic or manual starter; limit switch; others available.

*NOTE: Orientation of product may be affected because of straight rollers in curve. To maintain orientation, use tapered roller curve.

THOMAS CONVEYOR
and Equipment Company, Inc.
28 Hillside Avenue • Hillside, IL 60162-0736

Roach Conveyors-Thomas Conveyor and Equipment
28 Hillside Avenue- Hillside- IL- 60162- www.tceconveyors.com

■ 4 week shipment