



Toll Free 844-220-0086

RYSON

Product Spotlight

Narrow Trak Spiral Conveyor

“A super compact vertical conveyor for handling small loads”

This super compact Narrow Trak Spiral is designed to handle small loads and has an outside diameter of only 45". It will be a great space saver in addition to enabling high throughput.

This new NT 1000-120 model builds on Ryson's already proven quality and spiral technology that our customers have come to expect from us. Our modular design concept makes it easy to custom configure the spirals and meet the customers' specific requirements. It offers a significantly larger elevation change capacity than what is currently available in the small package marketplace today.

A new 5" wide slat has the capability to end-transfer small cartons and packages, or side-transfer small bottles and containers in a single file or in mass.

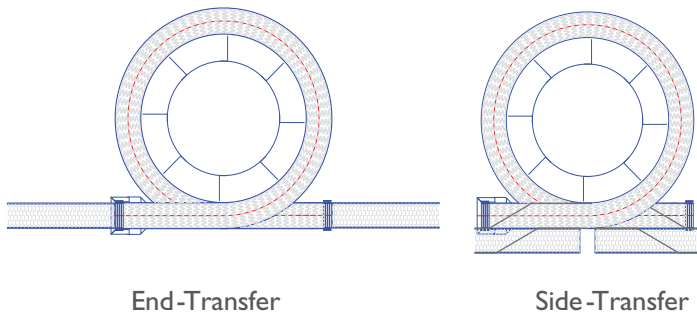

This compact unit is equipped with the Ryson proprietary low friction chain slat arrangement which assures high capacity, high speed, low energy consumption, low maintenance and long life. This new model will be especially beneficial for the pharmaceutical, nutraceutical, personal care and food products companies.

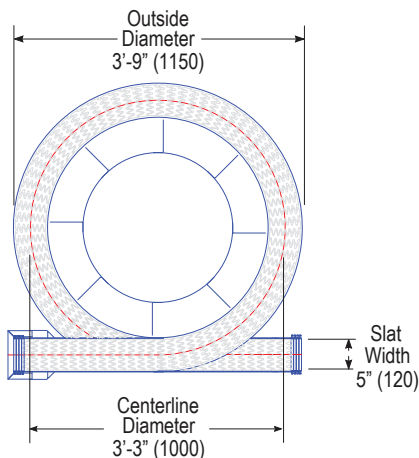

Modular Design:

The Ryson modular design makes our spirals easy to configure and customize. All our spirals are made to order and are available in three basic configurations as it relates to the position of the in and outfeed tangents as shown, (A, B, and C) The angle of the tangents can also be customized to meet specific layout requirements (B-MA for example) All configurations can operate up or down and in a clockwise or counterclockwise rotation.

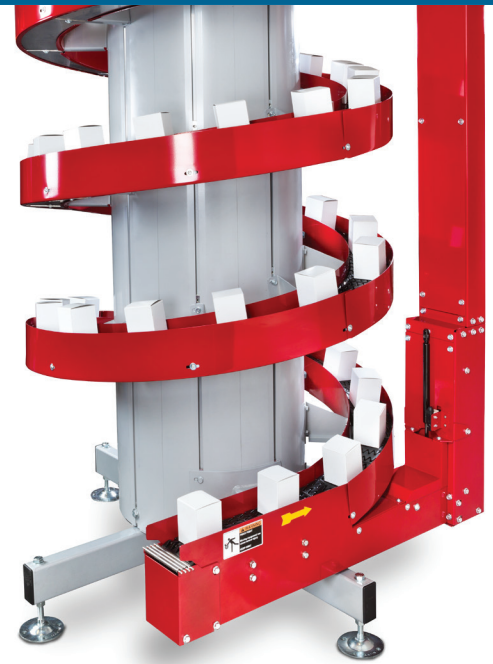
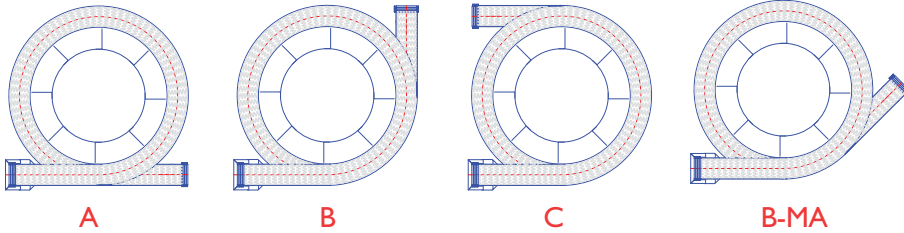

One Drive:

Only one drive motor is required, resulting in substantial savings in energy, controls and systems integration.

Overlapping Slats:

The 5" wide overlapping slats provide a smooth conveying surface and can be used for end-transfer or side-transfer. Friction inserts can be added when additional grip is required.

Built-in Protection:

The Narrow Trak Spiral includes an automatic chain tensioner and a built-in overload protection device.

Easy to Install:

The Narrow Trak Spirals ship in once piece, pre-assembled and pre-tested, reducing the time and cost of installation.

Low Maintenance:

All Ryson Spirals are designed for low maintenance and long life. Only high quality components are used throughout. All bearings are sealed for life and need no further lubrication. The chain is of heavy duty nickel plated construction and needs only infrequent lubrication. The slats need no maintenance and can easily be replaced as single components without the use of special tools.

Controls and Integration:

Each spiral includes an inverter duty gear motor and two proximity switches, one to sense a slack chain and one to sense any overload. Several pre-wiring and controls options are available.

All Ryson Spirals are thoroughly shop tested prior to shipment, but depend on proper integration with the overall conveyor system for optimum performance. Spiral integration instructions are available on www.ryson.com or give us a call to request a copy.



RYSON
INTERNATIONAL, INC

VERTICAL CONVEYING SOLUTIONS

Ryson is the number one Spiral Conveyor manufacturer in the USA.
For application assistance or more information, give us a call or visit www.ryson.com