

DEKKA®

EoL

END OF
LINE

DEKKA 100 SEMI-AUTOMATIC CASE SEALER



Perfect for light manufacturers operating a low-speed automated packaging line

The DEKKA 100 is a pressure sensitive, bottom belt, semi-automatic case sealer. It is designed to be the perfect pairing for the Dekka tape head, providing an economic and reliable case sealing solution.

The DEKKA 100 is able to handle a wide range of case sizes and can easily be changed to adapt different cases with a quick 2 point size change over. The machine is simple and easy to use with on machine infographic guides. The machine was designed with maintenance in mind with easy access to belt and tape head changes.

FEATURES AND BENEFITS

- Entry level case sealer is ideal for applications looking to upgrade from manual case sealing
- Compact machine footprint for applications with minimal floor space
- Reliable case sealing with the use of DEKKA E tape head
- Quick and easy size change with on machine pictorial guides and only 2 changeover points
- Deepest service support network across all of North America

DEKKA **DEKKA 100 SEMI-AUTOMATIC CASE SEALER**

SPECIFICATIONS

| | |
|-------------------|-----------------------------------|
| Weight | 300 lbs / 136 kg |
| Length | 39" / 990mm |
| Width | 25" / 635mm |
| Height | 50.5" / 1285mm |
| Electrical | 115VAC, 60 cycle, 1-phase, 4 amps |

CASE SIZE RANGE

| | Length | Width | Height |
|----------------|---------------|--------------|---------------|
| Minimum | 6" / 152mm | 6" / 152mm | 4" / 102mm |
| Maximum | Unlimited | 23" / 584mm | 20" / 508mm |

CONFIGURATION

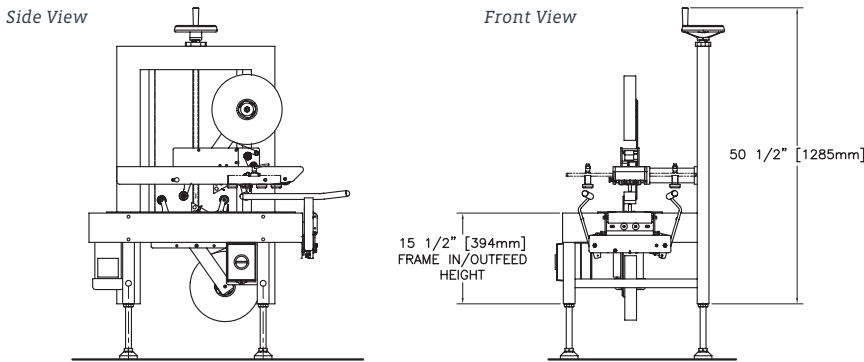

OPTIONS AND ACCESSORIES

- In/outfeed roller conveyor
- In/outfeed table
- Locking casters
- DEKKA SE stainless steel tape head
- KDF box stand
- DEKKA 100 spare parts kit

FEATURES



Color coded size change labels with pictorial guides



Bottom belt Uni-Drive system, allowing for a consistent seal over long term use



Quick size change with top wheel and tilting guide rails

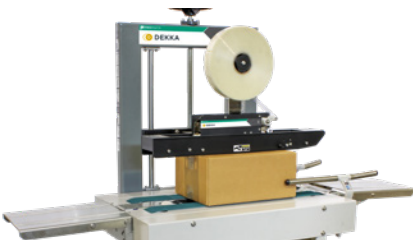

North American designed and developed with heavy duty quality and space saving construction

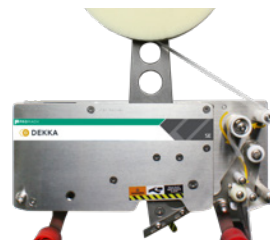

Utilizes industry leading DEKKA E tape head with an open design, making it easy to refill tape

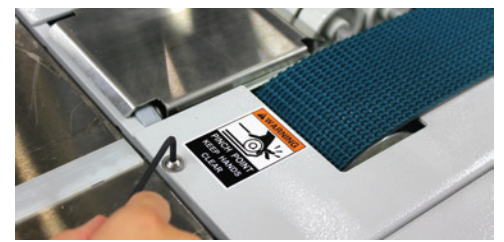

Access to belt and tape head changes for quick maintenance. Dekka has a deep support network all across North America