



OWNER'S MANUAL



Line Shaft Conveyors

Model 738LS • 738LSC • 796LS • 796LSC

DO NOT OPERATE BEFORE READING THIS HANDBOOK
KEEP IN A SAFE PLACE – DO NOT DISCARD

TECH HANDBOOK FOR LINE SHAFT CONVEYORS

TABLE OF CONTENTS

LINE SHAFT CONVEYOR TECH HANDBOOK	2	-Recommended Lubricants.....	14
-Caution Labels.....	2	-Report on Miscellaneous Maintenance Performed.....	14
CAUTIONS, WARNINGS AND HAZARDS	3	TROUBLE SHOOTING AND REPLACEMENT PARTS	15
-Introduction.....	3	-Trouble Shooting / Serial Plate.....	15
-Cautions, Warnings and Hazards.....	3	PARTS LISTS FOR LINE SHAFT CONVEYORS	16
SAFETY INFORMATION, ABOUT LINE SHAFT CONV.	4	-Parts List for 796LS with Underneath Mounted Drive.....	16
-Important Safety Guidelines.....	4	-Parts List for Intermediate 796LSI Bed Section.....	17
-About Line Shaft Conveyor.....	4	-Parts List for 738LS with Underneath Mounted Drive.....	18
RECEIVING AND INSPECTION	5	-Parts List for Intermediate 738LSI Bed Section.....	19
-Shortages, Damages and Return Authorizations.....	5	-Parts List for 796LSC 30° Curve Module.....	20
-Uncrating.....	5	-Parts for 796LSC 45° Curve Module.....	21
GENERAL INSTALLATION INFORMATION	6	-Parts List for 796LSC 60° Curve Module.....	22
-Coupling/Shaft End Cover Allocation.....	6	-Parts List for 796LSC 90° Curve Module.....	23
-Preparing for Setup.....	6	-Parts List for 796LSC 180° Curve Module 13-27BF.....	24
-Attaching Bed Sections and Shaft Couplings.....	7	-Parts List for 796LSC 180° Curve Module 31-39BF.....	25
-Identifying / Installing Permanent Floor Supports.....	8	-Parts List for 796LSS Spur Module.....	26
-Installation of Polytier Supports.....	8	-Parts List for 796LSSO Spur Only.....	27
-Installing Knee braces and Casters.....	9	-Parts List for 796LSSOX Spur Only with Crossover.....	27
-Installation of Ceiling Hangers.....	9	-Parts List for 796LSG Gate Module.....	28
START-UP PROCEDURES	10	-Parts List for 796LSX Crossover Module.....	29
-Drive Chain and Sprocket Alignment.....	10	-Parts List for 796LSXI Crossover Intermediate Module.....	30
-Drive Chain and Sprocket Tension.....	10	WARRANTY	31
-Gear Reducer with Posivent®.....	11		
-Preparing for Initial Start-Up.....	11		
MAINTENANCE SAFETY PRECAUTIONS	12		
-Before Performing Maintenance.....	12		
-Maintenance and Follow-Up Details.....	12		
MAINTENANCE AND LUBRICATION	13		
-Periodic Maintenance Schedule.....	13		

CAUTION LABELS



ABOVE: Label attached to all protective guards (drives, spool guards, etc.)

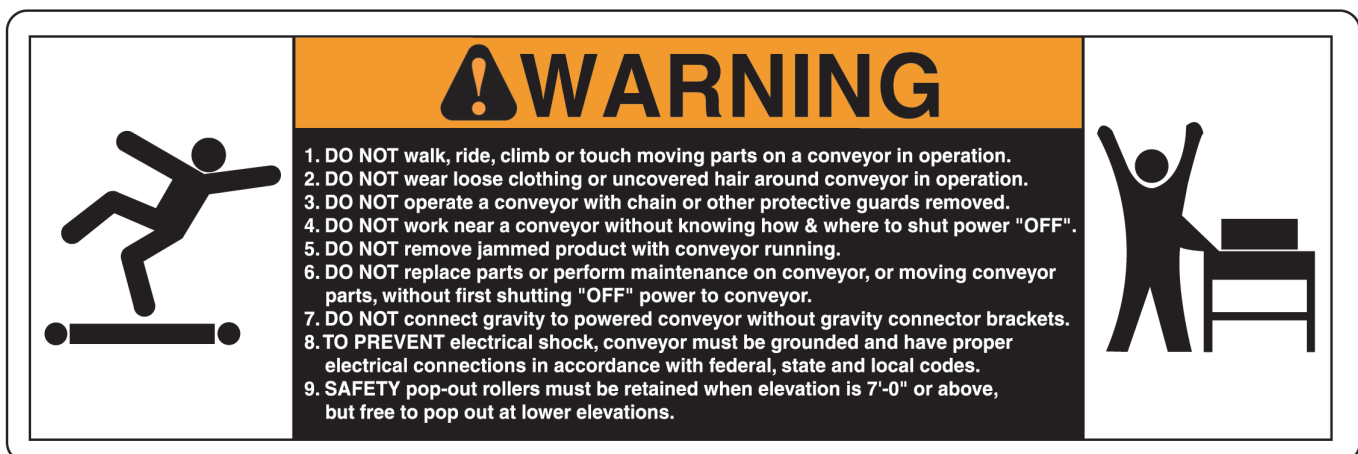

ABOVE: Label placed near all drive assemblies and at 30' intervals

This manual was prepared as a “how-to-guide” for installers, end-users and maintenance personnel. It is also intended to educate both owner (purchaser) and all individuals working around the unit, of potential hazards.

With proper installation and maintenance, conveyors are essential for achieving a variety of functions essential in today’s industrial marketplace. By following a simple, periodic maintenance schedule, the life of a typical conveyor (or, most any type of machinery--including our automobiles!) will increase when compared to a similar

unit in an application receiving little or no maintenance. You may find that a conveyor can become your best workplace friend by following simple safety guidelines. **Failure to follow even the most basic safety suggestions can result in serious personal injury.**

Conveyors contain many moving parts--pulleys, belting, chains, sprockets, shafts, rollers, etc. Therefore, it is imperative to become familiar with basic unit operation and know all points of potential hazards.

Remember, when working around or near conveyors (and **any** industrial machinery) it is **your** responsibility to become familiar with the unit, to know potential hazards (many are noted with caution labels) and to operate unit in strict accordance with the safety guidelines in this manual.

Keep this manual in a safe place for future reference. It should be placed where appropriate personnel may maintain proper maintenance and records.











This manual must be read by all new users before operating or working near this unit.

WARNING

**DO NOT OPERATE BEFORE READING THIS MANUAL!
KEEP IN SAFE PLACE--DO NOT DISCARD!**

CAUTIONS, WARNINGS AND HAZARDS

WARNING

-  NEVER connect belt conveyors directly to gravity conveyors, machinery or fixtures without using connector brackets & pop out roller.
-  ALWAYS anchor permanent supports to floor (or mounting surface). Use 3/8" x 2-1/2" (or longer) wedge anchors for permanent installation in concrete flooring.
-  It is the responsibility of the customer and installation personnel to supply and install net or mesh guarding on overhead mounted conveyors to prevent product and/or debris from falling to floor in areas where required.
-  If belt conveyor pulleys are adjusted during installation or maintenance, nip point guard (at drive end on end drive unit) must be readjusted. Nip point guard (take-up end) is automatically adjusted when take-up pulley is adjusted. Nip point guards at both ends of conveyor (center drive) must be readjusted. Center drive guards **MUST** be replaced after installation or maintenance.
-  Before unit is ready for operation, snub roller guard (cover) must be adjusted to ensure safe unit operation.
-  Belt lacing must be kept in good condition for safe work environment.
-  To check drive sprocket alignment, shut "OFF" and lock out power source before attempting any adjustments.
-  To check drive sprocket tension, shut "OFF" and lock out power source before any adjustments are attempted.
-  Electrical controls must be designed by a qualified electrical engineer to ensure that appropriate safety features (emergency stops, pull cords, switches, etc.) are installed on unit for safe operation. Before conveyor start-up, all operators and other personnel coming in contact with unit must be properly trained and must have read accompanying Tech Handbook.
-  Upon start-up, if belt tracks to one side, turn unit "OFF", lock out power source and confirm that conveyor is square and that all prime tracking components are square with bed. Belt tracking adjustments should be performed by trained personnel **ONLY**. Read section on "Belt Tracking" completely before attempting belt tracking adjustments.
-  Only trained personnel shall perform maintenance functions. Before maintenance operations are performed, shut conveyor "OFF" and lock out power source to prevent unauthorized start-up. When maintenance is completed, only authorized personnel shall be permitted to start conveyor following maintenance or other emergency shut-off.

SAFETY INFORMATION

IMPORTANT SAFETY GUIDELINES

⚠️ WARNING

WARNING: All personnel coming in contact with this conveyor should be aware of the following safety guidelines **BEFORE USING OR WORKING AROUND CONVEYOR**. **NOTE: ALWAYS** notify Roach Manufacturing® whenever any conveyor is used in an application or condition other than was originally intended. Failure to notify Roach® may allow conveyor to be operated in a hazardous operating condition. Injuries resulting from negligence or violation of safety instructions hereby removes responsibility of product liability claims from Roach®.



Do not operate conveyor with protective guards removed. This includes chain guards, belt guards, snub roller guards, center drive guards and any other safety guard.



Do not walk, ride, climb, or touch moving parts on a conveyor in operation.



Do not wear loose clothing or uncovered hair around conveyor.



Do not work near conveyor without knowing how & where to shut power "OFF" and lock out power source.



Do not remove jammed product with conveyor running.



Do not replace parts or perform maintenance on conveyor, or moving conveyor parts, without first shutting "OFF" power to conveyor and locking out power source.



Do not connect gravity to powered conveyor without safety gravity connector brackets.



To prevent electrical shock, conveyor must be grounded, and have proper electrical connections in accordance with federal, state, and local codes.



Safety pop out rollers in conveyors installed above 7'-0" elevation must be retained by guard rail, clips, etc. Safety pop out rollers must be allowed to pop out when

conveyors are installed at or below 7'-0" elevation.



It is the responsibility of conveyor end-user to comply with all safety standards including OSHA and other federal, state, and local codes or regulations. Install protective guarding and other related safety precautionary equipment to eliminate hazardous operating conditions which may exist when two or more vendors supply machinery for related use.



Any violation of above safety instructions hereby removes all product liability claims from Roach Manufacturing Corporation®.

ABOUT LINE SHAFT CONVEYOR

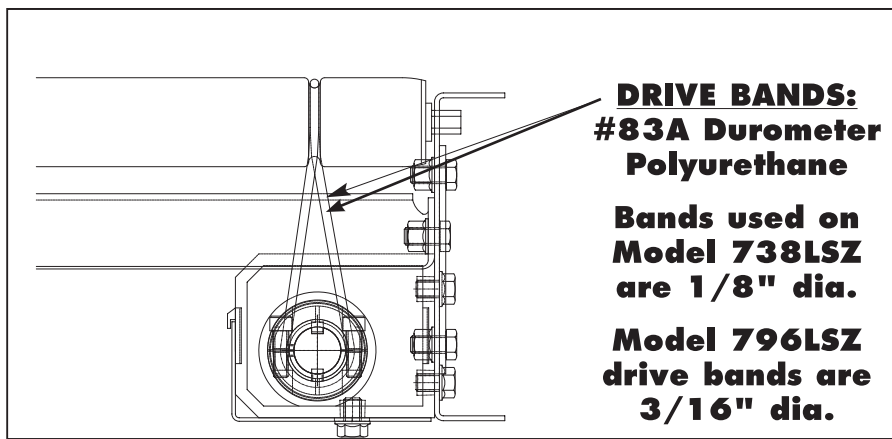

Note: Extra drive bands are installed on the unit at the factory on drive shaft between baring locations allowing future use with minimal installation effort.

Roach line shaft conveyor, when appropriately applied, is one of the most economical and efficient types of powered conveyor to incorporate into your overall material handling system. Numerous accessories and several intermediate sections may be driven with a single drive which eliminates costs from the actual drives and from motor drive component electrical costs.

Extra drive bands are installed on the unit at the factory on drive shaft between bearing locations allowing future use with minimal installation effort.

DO NOT USE LINE SHAFT CONVEYORS:

- When rollers must be skewed (for product positioning) greater than 5 degrees.

If line shaft **MUST** be used, limit skewing to short unit sections and use low friction guard rail.

- When excessive speeds are necessary-- 15 FPM or less OR faster than 120 FPM.
- In oily or wet conditions which impair the frictional driving forces required.
- In corrosive or abrasive applications.
- When the drive bands are exposed to direct ultraviolet rays.

RECEIVING AND INSPECTION SHORTAGES, DAMAGES AND RETURN AUTHORIZATIONS

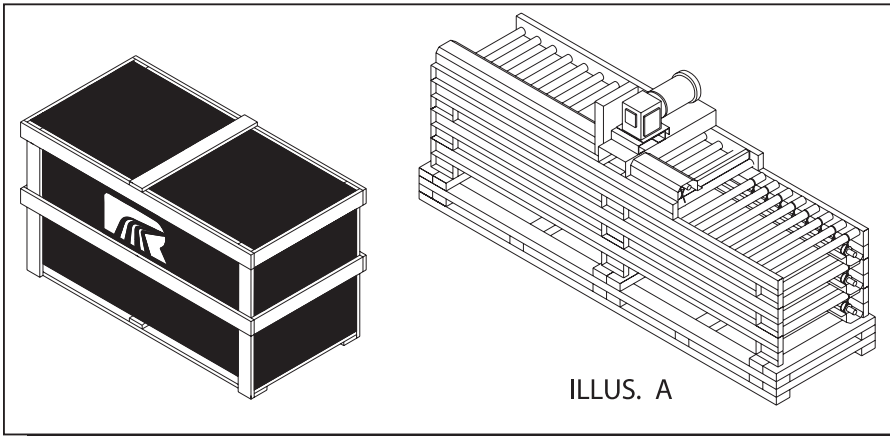

NOTE: Do not return goods to factory without prior, written return authorization. Unauthorized returns are subject to refusal at factory.

Before uncrating, check the quantity of items received against bill of lading to confirm that all material has been received. Examine the condition of the equipment to determine if any damage has occurred.

Also, it is possible that some items may become separated from the original shipment. Therefore, when receiving goods, it is imperative that the bill of lading (or,

accompanying freight documentation) be checked to ensure receipt of ALL units ordered including ALL accessories.

Damage and/or shortage in shipment should be reported immediately to both vendor and carrier. Obtain a signed damage report from carrier agent and send copy to vendor. **Do not repair any damage before obtaining this report.**

For damaged shipments, consult factory to determine if entire shipment must be returned to factory for repair or if an immediate order should enter production to produce a new, replacement shipment.

In illustration A above, model SZ796LSZ is shown palletized, prepared for shipment.

UNCRATING

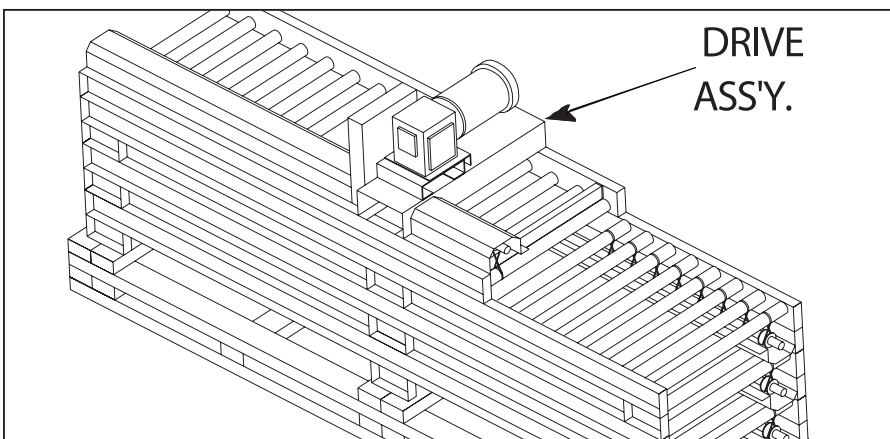

NOTE: Carefully examine shipment during uncrating to ensure that essential components are not discarded. This includes guard rail and other necessary hardware.

After receipt and initial inspection is completed, carefully remove crating and look for essential components and specific accessories that may have been boxed and attached (or 'banded') to crating material. Guard rails and hardware are often pack-

aged and shipped in this manner. Save all hardware for subsequent use by installation personnel.

The drive section will be shipped mounted to its actual operating bed section (see illustration above).

Some items (electric motors, gearbox, etc.) may be shipped direct from their manufacturer to final destination. Thus, the conveyor may consist of two or more separate shipments.

GENERAL INSTALLATION INFORMATION

COUPLING/SHAFT END COVER ALLOCATION

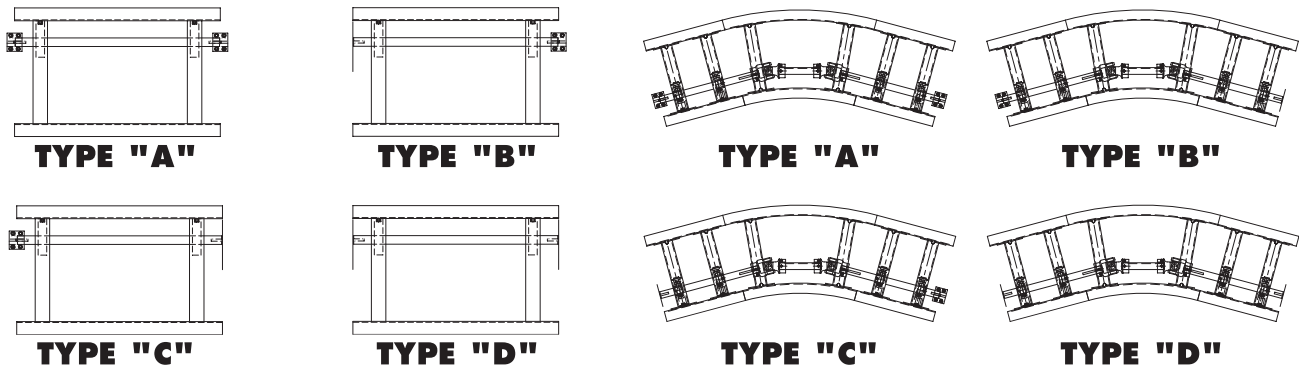

It is only necessary to place a shaft coupling on the end of the drive shaft where it is to connect to another bed section or line shaft unit accessory. Allocation of line shaft Coupling for LS conveyors is illustrated in diagram above. Model LS ships from the factory in one of four configurations above and each unit is marked on its corresponding packing list as either type "A", "B", "C" or "D". This marking procedure

applies to the end drive shaft coupling only at both ends. Therefore, on units **with** motor drive, this applies to the coupling arrangement at each end of the overall unit--not at intermediate bed sections. For units ordered as intermediate bed sections only (without drive), illustration applies to **each** bed section. On Curved sections, model LSC, four coupling configurations are possible with units marked

type "A", "B", "C", or "D". This marking procedure applies to the end drive shaft coupling at both ends of each curved section. Fully tighten and maintain proper shaft alignment if coupling assembly is added or adjusted in the field.

PREPARING FOR SETUP

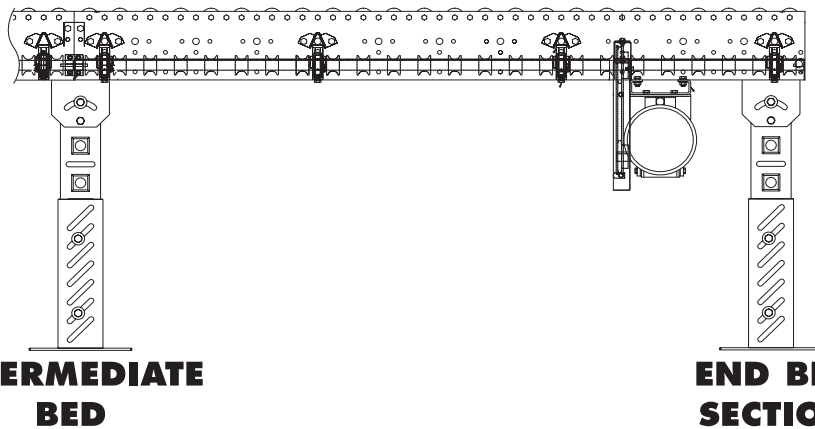

NOTE: When preparing to install conveyor, first locate all component sections in the actual installation area. After uncrating, place bed sections conveying side up.

Conveyors are set up at the factory, unit is test run and receives rigorous quality assurance inspection. At this time unit becomes field-ready. When preparing to install conveyor, first locate all component sections in the actual installation area. After uncrating, place unit bed sections conveying side up. Refer to bed section drawing (supplied with

shipment and packing list) for location of supports and assemble as shown. Create a reference base line on floor by marking a chalk line along the centerline of conveyor. Follow base line when installing unit. Conveyor must be level and square or packages will run off to one side. Check level across width of unit. Then confirm that unit is square. A diagonal

measurement can determine bed section squareness. **Conveyor must be square and level or packages will run off to one side.** Use mechanical hoist (fork truck or other available means) to raise bed sections to approximate installed elevation. Drive shaft and bed sections are now ready to be attached (and adjusted if necessary) as explained in following section.

GENERAL INSTALLATION INFORMATION

ATTACHING BED SECTIONS AND SHAFT COUPLING

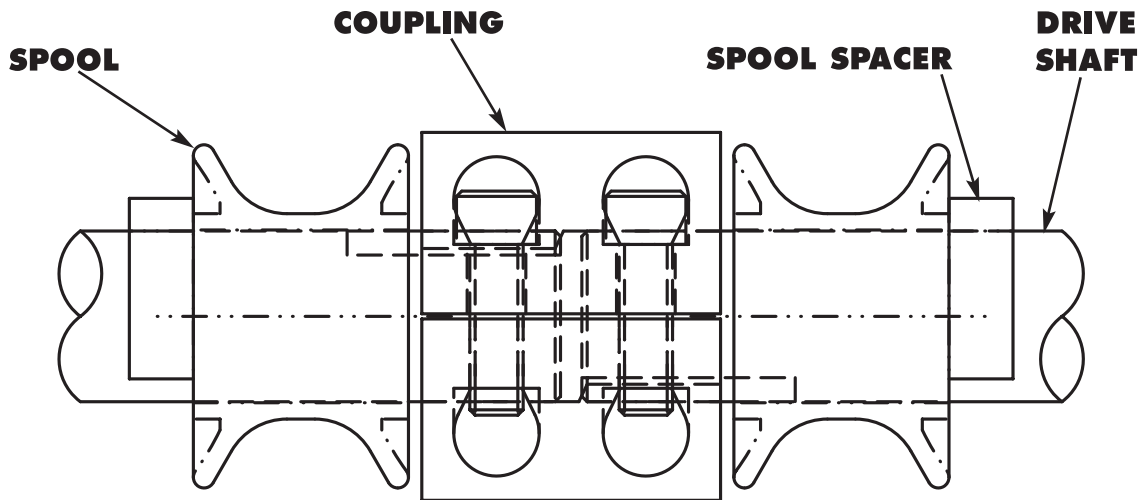

PROPER ALIGNMENT

The following procedure is recommended when installing intermediate line shaft bed sections.

1. Raise the first bed section to the approximate installed elevation and place floor support under each end as shown on page 6.

2. Move the next adjoining bed into position and place on support.

NOTE: Each floor support commonly supports 2 intermediate beds.

3. Next, loosen coupling screws and insert into coupling at end of first bed section.

4. Align coupling assembly and tighten coupling screws.

5. Then attach beds together by connecting splice plates.

6. Securely tighten bolts in splice plates and in floor support top cap assembly.

NOTE: Insert coupling screws from

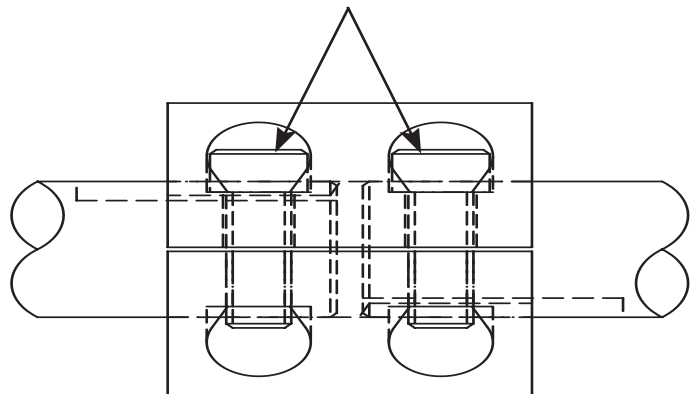

NOTE: Properly seat keys before ... tightening coupling screws.

GENERAL INSTALLATION INFORMATION

IDENTIFYING/INSTALLING PERMANENT FLOOR SUPPORTS

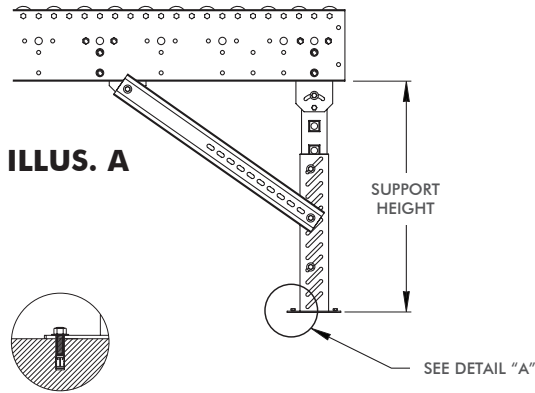

ILLUS. A

Detail "A"

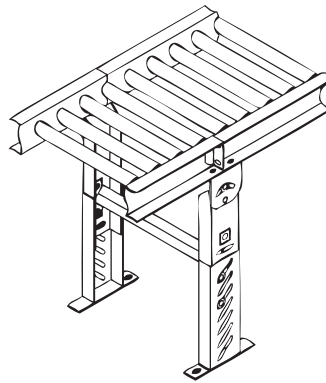

ILLUS. B

⚠ WARNING

Always anchor permanent supports to floor (or mounting surface). Use 3/8" x 2-1/2" (or longer) wedge anchors for permanent installation in concrete flooring.

*MINIMUM/MAXIMUM SUPPORT HEIGHT			
SM-1	7-1/4"—10-1/4"	SM-7	34-1/4"—46-1/4"
SM-2	10-1/4"—13-1/4"	SM-8	46-1/4"—58-1/4"
SM-3	13-1/4"—16-1/4"	SM-9	58-1/4"—70-1/4"
SM-4	16-1/4"—22-1/4"	SM-10	70-1/4"—82-1/4"
SM-5	20-1/4"—26-1/4"	SM-11	80-1/4"—92-1/4"
SM-6	24-1/4"—36-1/4"	SM-12	92-1/4"—104-1/4"

Permanent supports may be installed on conveyors at various locations. However, it is most common to use single tier permanent floor supports at each end of a powered section (see illustration A above) and where intermediate bed sections are adjoined (see illustration B above). Notice intermediate supports have two lag bolts in a diagonal pattern while end (terminal) supports have four lag bolts, one in each of

the four foot plate mounting holes. When two (or more) powered conveyors are placed end-to-end, a single tier permanent support may be used at the end junction commonly supporting both units. Check load rating of support before using this method of installation. Adjust elevation to top of conveyor by loosening bolts in support uprights, raising

or lowering conveyor and fully tightening bolts at desired elevation. Tighten all bolts in supports **before** unit operation. Complete support installation by lagging support attachment plates to floor. Confirm that unit is level across width of conveyor before completing final support height adj. *Supports are normally shipped at minimum support height. See chart above.

INSTALLATION OF POLYTIER SUPPORTS

**MIN. ELEVATION = 11" ELEV.
(3-1/2" + FRAME)**

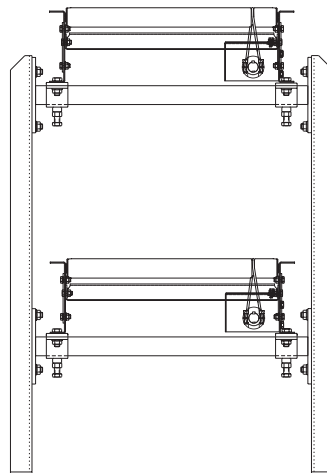

NOTE: To install, raise conveyor to desired elevation, place cross pipe underneath frame, attach cross pipe to upright legs and use U-shaped retainer ("hat") bracket to connect cross pipe to lower conveyor flange.

POLYTIER SUPPORT CHANNEL HEIGHT					
PSM-1	23"	PSM-6	53"	PSM-11	83"
PSM-2	29"	PSM-7	59"	PSM-12	89"
PSM-3	35"	PSM-8	65"	PSM-13	95"
PSM-4	41"	PSM-9	71"	PSM-14	101"
PSM-5	47"	PSM-10	77"	PSM-15	107"

Polytier supports provide convenient installation method for two or more tiers of conveyor. To install, raise conveyor to desired elevation (approximate). Place 1" inside diameter cross pipe underneath lower conveyor flange. Attach cross pipe to upright legs. Use U-shaped retainer ("hat")

bracket with coupling plate to connect cross pipe to conveyor flange. Do not tighten fully at this time. Standard elevation style attachment brackets offer unit elevation of 3-1/2" + frame and includes bracket welded to cross pipe

which is bolted to upright legs during installation. When unit is at operating elevation and unit has been checked across width for level, tighten locking bolts in U-shaped bracket. Add knee braces for unit rigidity.

GENERAL INSTALLATION INFORMATION

INSTALLING KNEE BRACES AND CASTERS

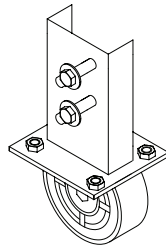
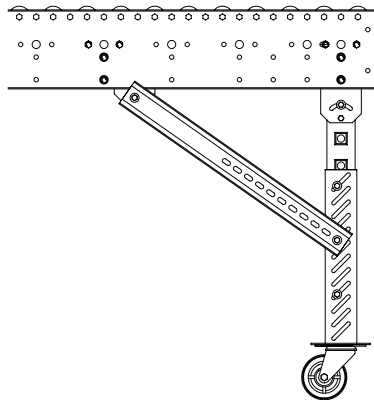

NOTE: Install knee brace (when supplied) after final permanent support installation and elevation adjustment.

Knee braces add strength to permanent supports and stability to units in portable applications. Install knee brace (when supplied) after final permanent support installation and elevation adjustment. Its pivot bracket is bolted to underneath side of lower conveyor flange and slotted end is attached to outer side of support.

Castors (when supplied) are generally installed at the factory. However, when receiving casters direct from their supplier, final attachment to support is necessary. A special slotted pre-punched caster attachment plate is supplied on supports designed for casters.

A standard support is not designed for attachment to casters. Field modification or replacement of outside support assemblies is required.

INSTALLATION OF CEILING HANGERS

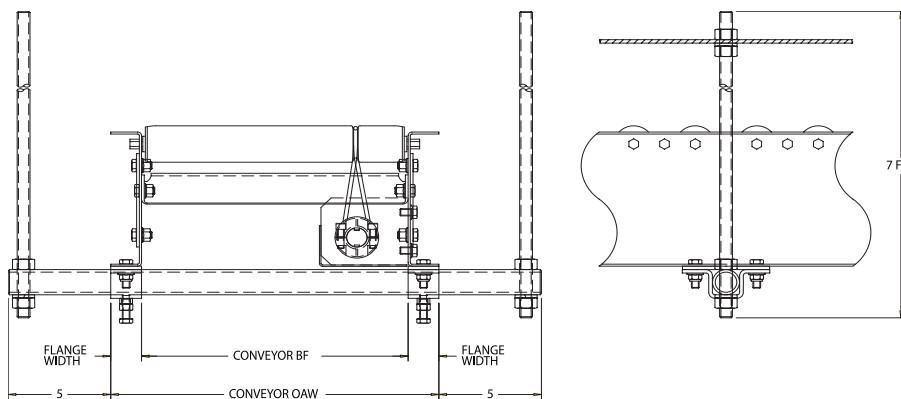

⚠ WARNING

It is the responsibility of the customer and installation personnel to supply and install net or mesh guarding on conveyors mounted overhead to prevent product and/or debris from falling to floor in areas where required.

Ceiling hangers are frequently used in high-elevation applications for suspension from ceiling. The 5/8" diameter (#11 UNC) all threaded rod is supplied to allow infinite vertical adjustment along the length of the suspension rod (see illustration above).

Attach and firmly tighten U-shaped retainer ("hat") bracket with coupling plate to

underneath side of frame with hardware provided to hold cross pipe (1" inside diameter) against underneath side of conveyor.

Do not tighten cross pipe locking bolts (these attach in the bottom of the U-shaped retainer bracket) until threaded suspension rods have been firmly secured to ceiling structure.

To adjust conveyor elevation, tighten or loosen lower nut and jam nut on threaded suspension rods to desired elevation. A lock washer must be used on suspension rods to maintain unit at desired elevation.

When unit is at operating elevation and unit has been levelled across bed width, tighten locking bolts in U-shaped bracket to secure position of cross pipe.

START-UP PROCEDURES

DRIVE CHAIN AND SPROCKET ALIGNMENT

CHAIN GUARD REMOVED FOR CLARITY

WARNING: DO NOT OPERATE CONVEYOR WITH CHAIN GUARD REMOVED

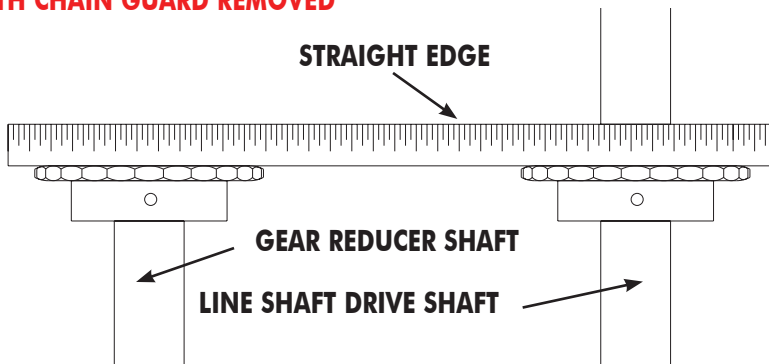

Set up and maintenance of drive sprocket and drive chain alignment is critical. A periodic visual inspection is recommended to confirm alignment of drive components (which includes both drive sprockets and drive chain). Should set screws become loose, drive sprockets are subject to excessive wear and ultimately, to untimely replacement.

To check drive sprocket alignment, it is imperative that conveyor is shut "OFF" and power source is locked out before any adjustments are attempted. Remove chain guard cover and place straight-edge (see illustration above) across face of both drive sprockets. If re-alignment is necessary, loosen set screws and adjust drive

WARNING

To check drive sprocket alignment, it is imperative that conveyor is shut "OFF" and power source is locked any out before any adjustments are attempted.

sprockets as required. **Remember to securely tighten set screws when alignment is complete.**

Before replacing chain guard cover, check drive chain tension as described in following section, "Drive Chain and Sprocket Tension."

DRIVE CHAIN AND SPROCKET TENSION

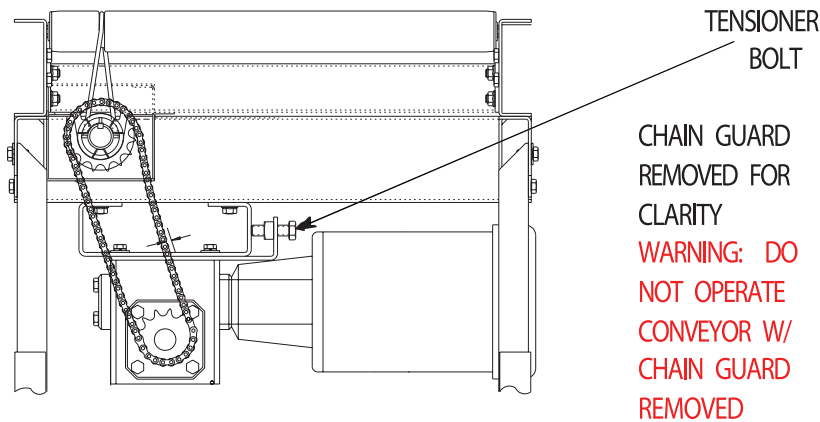

Maintaining proper chain tension is especially important. Again, a periodic visual inspection is recommended to ensure chain tension within a pre-determined operating range.

Remember, before any adjustments are attempted, conveyor must be shut "OFF" and power source locked out.

Before replacing chain guard cover, check

WARNING

To check drive sprocket tension, shut "OFF" and lock out power source before any adjustments are attempted.

To adjust drive chain tension:

- Step 1 - Loosen the (4) bolts that hold the gear reducer to the motor baseplate
- Step 2 - Tension bolt located on reducer push plate should be tightened (rotate clockwise) if chain is too loose and loosen (rotate counter clockwise) if chain is too tight. Tighten until proper operation range is achieved.
- Step - 3 Tighten the (4) bolts that hold the gear reducer to the motor base plate.
- Step - 4 Replace all guards that were removed.

WARNING: Do not operate unit until chain guard cover is replaced. Serious operator or other personal injury could result if protective guarding is not replaced.

START-UP PROCEDURES

GEAR REDUCER WITH POSIVENT[®]

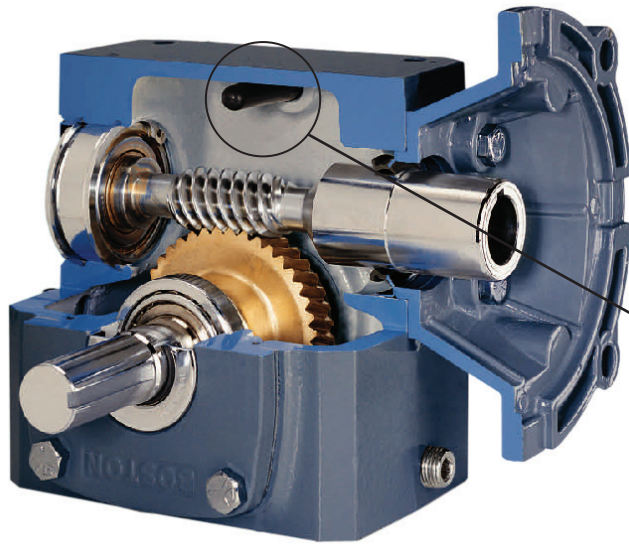

NOTE
The gear reducer is supplied with a "PosiVent[®]". No vent plugs are required.

PosiVent Unique design incorporates a single seam construction. Factory filled with synthetic lubrication for universal mounting. Lubed for life, no oil changes are required.

To expedite the installation and start-up process, all gear reducers are shipped filled with oil. The reducers are sealed and lubed for life and require no oil changes.

PREPARING FOR INITIAL START-UP



⚠ DANGER
WARN ALL PERSONNEL TO KEEP CLEAR OF CONVEYOR DURING UNIT START-UP
Electrical controls must be designed by a qualified electrical engineer to ensure that appropriate safety features (emergency stops, pull cords, switches, etc.) are installed on unit for safe operation. Before conveyor start-up, all operators and other personnel coming in contact with unit must be properly trained and must have read accompanying Tech Handbook.

Before conveyor start-up, all operators and other personnel coming in contact with unit must be properly trained and must have read accompanying Tech Handbook.

Provisions must be in order to instruct all personnel coming in contact with conveyor on the location of emergency stops, pull cords, etc.

A routine maintenance program should be implemented before unit is placed into operation so that fundamental unit components are attended to. This maintenance program should include an inspection to ensure that any dangerous or hazardous operating conditions are noted and IMMEDIATELY corrected, as well as including electrical and mechanical unit inspections and corrections.

Finally, when conveyor is initially started, an immediate visual inspection should include motor, gear reducer, belt tracking (discussed in following section under "Belt Tracking") and related adjustments noted in handbook for unit/component corrections.

MAINTENANCE SAFETY PRECAUTIONS BEFORE PERFORMING MAINTENANCE

WARNING

Only trained personnel shall perform maintenance functions. Before maintenance operations are performed, conveyor must be shut "OFF" and disconnects locked in the "OFF" position to prevent unit from unauthorized start-up.

One of the most important guidelines for maximizing conveyor operation and personnel safety is to implement a regular maintenance schedule and train personnel on the appropriate needs of the specific unit.

Only trained personnel shall perform maintenance functions. Before maintenance operations are performed, conveyor must be shut "OFF" and disconnects locked in the "OFF" position to prevent unit from unauthorized start-up during maintenance. All personnel should be informed of the safety procedures associated with unit maintenance and performance.

Do not perform any work on conveyors or conveyor system while in operation unless it is impossible to otherwise conduct adjustment, lubrication or other maintenance function. Only experienced, trained personnel possessing advanced hazards-training should attempt such critical operations.

MAINTENANCE AND FOLLOW-UP DETAILS

WARNING

Only trained personnel shall perform maintenance functions. When maintenance is completed, only authorized personnel shall be permitted to start conveyor following maintenance or other emergency shut-off.

While performing maintenance do not wear loose clothing. Immediately report any hazardous conditions--sharp edges, pinch (or nip) points or other conditions that may result when several manufacturers supply machinery which may create operating hazards.

When using mechanical aids such as hoists, cables, or cranes exercise extreme caution to prevent damage to conveyors or other integrated machinery which may create a working hazard when maintenance is completed and units are in operation.

Clean up any spilled lubricants or other materials used in the maintenance process or those which may be deposited during unit operation. Eliminating poor housekeeping practices increases unit efficiency while creating safer personnel working conditions.

After maintenance, conduct visual inspection to ensure that all safety devices and guards have been replaced. Confirm that all units are clear of tools, debris or other items. Before starting conveyor, check condition of unit caution labels (see "CAUTION LABELS" at front of handbook). If labels have been destroyed or are not clearly legible, call 870.483.7631 to receive replacement labels. Placement of caution labels is critical to avoid unauthorized unit operation which may result in hazardous working conditions for all related personnel coming in contact with conveyor.

Warn personnel that conveyor is being prepared for start-up and to stay clear of unit. Do not start conveyor until all personnel are clear. When maintenance is completed, only authorized personnel shall be permitted to start conveyor following maintenance or other emergency shut-off.

MAINTENANCE AND LUBRICATION PERIODIC MAINTENANCE SCHEDULE

MODEL NO. _____

WEEKLY RECOMMENDED MAINTENANCE SCHEDULE*	
COMPONENT	DETAIL OF MAINTENANCE
Bearings	Lubricate in dirty, dusty, or moist/wet conditions.
Unit Safety Check	Confirm placement of all guards, pop-out rollers, warning labels & check for loose bolts, nip points & other hazards.

MONTHLY RECOMMENDED MAINTENANCE SCHEDULE*	
COMPONENT	DETAIL OF MAINTENANCE
Gear Reducer	Check for leaks.
V-Belt Drive Belt	Check for proper operating tension & overall wear.
Drive Sheaves	Check & re-tighten set screws & check for overall wear.
Pillow Block / Flange Bearings	Lubricate (normal conditions).
Drive Chain	Check for proper operating tension & overall wear & lubricate.
Drive Sprockets	Check for overall wear & re-tighten set screws.

PERIODIC RECOMMENDED MAINTENANCE SCHEDULE*	
COMPONENT	DETAIL OF MAINTENANCE
Gear Reducer	Check for leaks.
Drive Chain	Clean (brush in solvent) & re-lubricate by applying lubricant to inside of chain with brush or spout can at 2000 hour intervals.
Motor	Check & clear motor ventilation openings at 500 hour intervals Check miscellaneous operating conditions (normal heat & noise).

*All charts are for guidelines in normal operating or 'as noted' conditions. Severe applications may warrant additional maintenance.

TROUBLE SHOOTING AND REPLACEMENT PARTS

TROUBLE SHOOTING / SERIAL PLATE

TROUBLE SHOOTING		
TROUBLE	PROBABLE CAUSE	REMEDY
Motor & gear reducer running excessively hot, or hard to start	A. Lack of lubricant B. Frozen sprocket C. Overload D. Electrical	A. Check for leaks. B. Check and inspect all sprockets and bearings. Replace sprockets failing to rotate or that are difficult to rotate. C. Reduce cause and/or increase motor horsepower. D. Check wiring and circuits, take ampere reading, replace motor if necessary.
Motor & gear reducer makes excessive noise	A. Lack of lubrication B. Damaged Gears C. Faulty Bearing	A. Check for leaks. B. Replace unit. C. Replace bearing.
Drive chain, conveying chain or sprockets experience excessive wear	A. Excessive chain tension B. Sprockets misaligned C. Chain not lubricated D. Damaged sprocket or chain E. Misalignment of chain guard F. Dirty chain	A. Reduce chain tension. B. Realign with straight edge across sprocket faces. C. Lubricated chain with approved lubricant, wipe away excess lubricant. D. Replace Damaged Component. E. Adjust chain guard assembly as necessary. F. Clean thoroughly and lubricate with approved lubricant.
Drive chain, conveying chain or sprockets make excessive noise	A. Insufficient chain tension B. Chain not adequately lubricated C. Sprockets misaligned	A. Adjust chain tension. B. Lubricate chain with approved lubricant, wipe away excess lubricant. C. Realign sprockets with straight edge across sprocket faces.
Pulsating chain	A. Insufficient chain tension B. Misalignment of chain guard C. Overload	A. Adjust chain tension. B. Adjust chain guard assembly as necessary. C. Inspect for obstruction to or drag on conveyor.
Broken chain	A. Frozen bearing or sprocket shaft B. Worn or damaged chain C. Obstructed or jam	A. Inspect for damaged bearings, replace if necessary. Replace links as required. B. Replace chain as required. C. Remove obstruction to clear jam.
Tread roller(s) stalls or does not turn when loaded	A. Product overload B. Drive band broken C. Oil conditions D. Frozen roller bearing	A. Alter product loading to specified load rating. Consult factory. B. Replace drive band. C. Remove oil with recommended cleaner. D. Replace roller.
Sprocket loose on shaft	A. Loose set screws B. Worn or damaged key	A. Realign sprockets with straight edge and tighten set screws. B. Replace with new key.
Excessive slack in chain	A. Normal wear	A. Expect rapid chain growth in first two weeks of operation. B. Adjust chain tension as specified in the manual.

ORDERING REPLACEMENT PARTS



ROACH CONVEYORS
 808 HIGHWAY 463
 TRUMANN, AR 72472
 TEL 870-483-7631

SERIAL NO. 123456

To order any replacement parts or when calling for assistance with any powered conveyor, **ALWAYS** provide the unit serial number. Shown at actual size, this is placed on the conveyor frame near the location of the drive assembly.

To order replacement parts or add-on components, contact the Roach distributor who originally furnished the unit

if possible. If this is not possible, contact the National Sales Office at 870-483-7631 for the name of the authorized Roach distributor in your area. Have unit model number and serial number **BEFORE** calling. Refer to unit drawings (in rear section of handbook) for part numbers if ordering replacement parts.

PARTS LIST FOR LINE SHAFT CONVEYORS 796LS WITH UNDERNEATH MOUNTED DRIVE

ITEM #	DESCRIPTION	ITEM #	DESCRIPTION
1	LS Splice Plate		Chain Guard Top Cover Chain Guard Filler Chain Guard Cover Reducer Push Plate Motorbase Plate Motorbase Stiffener Assembly
2	Mainline Drive Spool Shaft (24"-120" LG)		
3	196 Grooved Roller Assembly (A37089-BF)		
4	Front Drive Spool Guard 3", 4", 6" RC		
5	Drive Spool Guard 3", 6" RC (24"-120" LG) 4" RC (24"-120" LG)	16	Reducer Spacer Channel
6	796LS Frame Crossbrace	17	1/4" SQ x 7/8" LG Keystock
7	Side Channel 3", 4", 6" RC	18	Coupling Assembly (A38222)
8	Lineshaft Pillow Block Bearing (BRW04125)	19	Lineshaft End Kit Assembly End Cover Guard 1/4" X 1/2" Whiz Lock Bolt 1/4" Steel Spring Nut
9	3/8" x 1/2" LG Hex WHFB	20	Motor
10	Lineshaft Spool (BRW04602)	21	Reducer
11	3/8" x 3/4" LG HHCS	22	Drive Sprocket (SPW50172)
12	3/8" Flange Nut	23	Reducer Sprocket
13	Spool Spacer (MCW06447)	24	Drive Chain (SPW00500) Connection Link (SPW10500)
14	3/16" DIA. x 13" Drive Band (VBW71364)		
15	796 Lineshaft Drive Kit Chain Guard Top Cap		

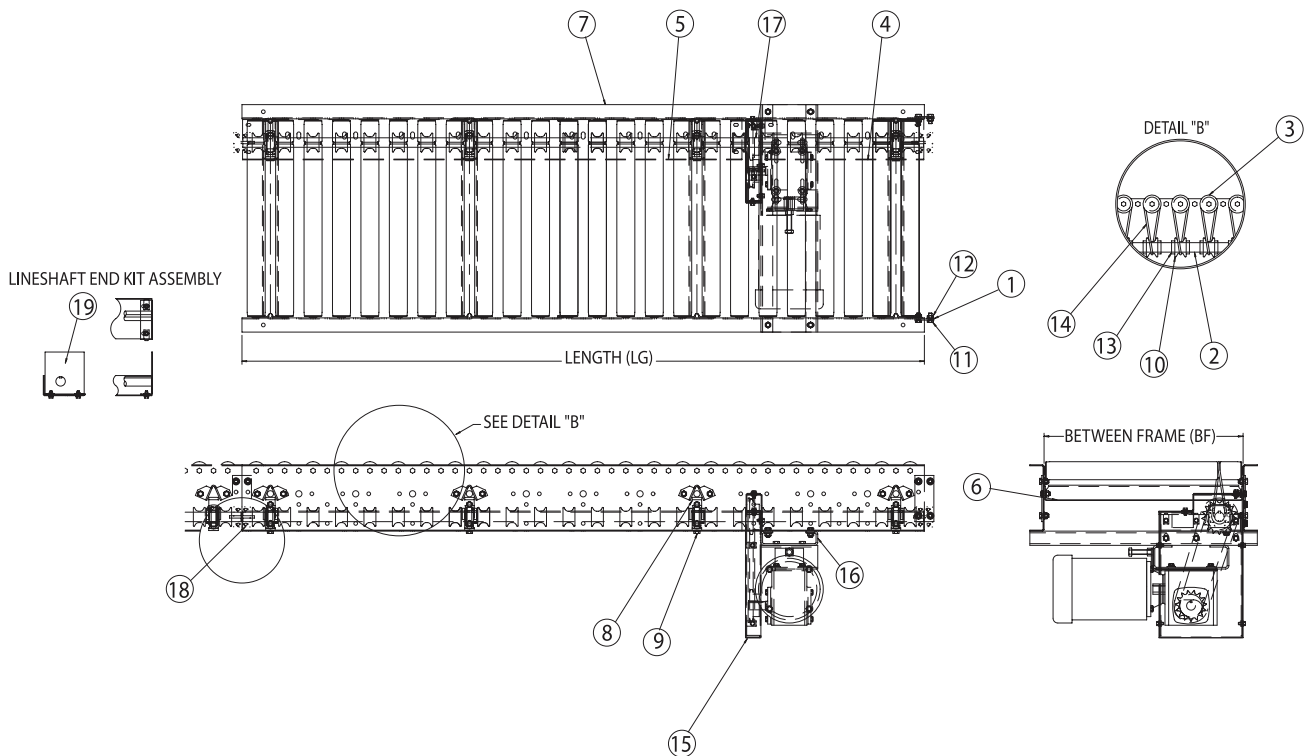

Specify **Unit Serial Number** when ordering replacement parts to ensure proper allocation of components (See Ordering Replacement Parts on page 15).

Recommended Spare Parts are shown in red. Charted are item no. and part description

When ordering use example below.

Example: Need a replacement Motor for 796LS with underneath mounted drive

Part No: SN 123456 - 20 - Motor



ROACH CONVEYORS
808 HIGHWAY 463
TRUMANN, AR 72472
TEL 870-483-7631

SERIAL NO. 123456

PARTS LIST FOR LINE SHAFT CONVEYORS INTERMEDIATE 796LSI BED SECTION

ITEM #	DESCRIPTION	ITEM #	DESCRIPTION
1	LS Splice Plate	8	3/8" x 1/2" LG Hex WHFB
2	Mainline Intermediate Spool Shaft (12"-120")	9	Lineshaft Spool (BRW04602)
3	196 Grooved Roller Assembly (A37089-BF)	10	3/8" x 3/4" LG HHCS
4	Intermediate Spool Guard 3", 6" RC (12"-120") 4" RC (24"-120")	11	3/8" Flange Nut
5	796LS Frame Crossbrace	12	Spool Spacer (MCW06447)
6	Side Channel 3", 4", 6" RC	13	3/16" DIA. x 13" Drive Band (VBW71364)
7	Lineshaft Pillow Block Bearing (BRW04125)	14	Coupling Assembly (A38222)
		15	Lineshaft End Kit Assembly End Cover Guard 1/4" x 1/2" Whiz Lock Bolt 1/4" Steel Spring Nut

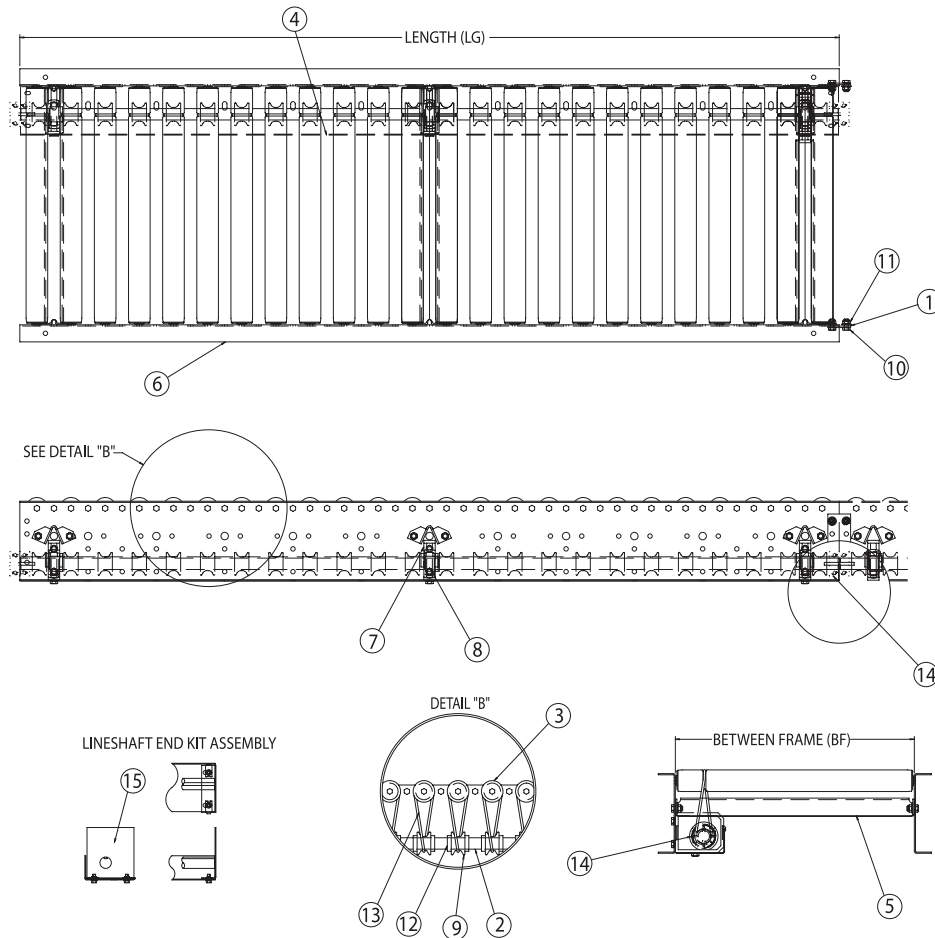

Specify **Unit Serial Number** when ordering replacement parts to ensure proper allocation of components (See Ordering Replacement Parts on page 15).

Recommended Spare Parts are shown in red. Charted are item no. and part description

When ordering use example below.

Example: Need a replacement 196 Grooved Roller Assembly (A37089-BF) for Intermediate 796LSI Bed Section

Part No: SN 123456 - 3 - 196 Grooved Roller Assembly



ROACH CONVEYORS
 808 HIGHWAY 463
 TRUMANN, AR 72472
 TEL. 870-483-7631

SERIAL NO. 123456

PARTS LIST FOR LINE SHAFT CONVEYORS 738LS WITH UNDERNEATH MOUNTED DRIVE

ITEM #	DESCRIPTION	ITEM #	DESCRIPTION
1	LS Splice Plate		Chain Guard Top Cover Chain Guard Filler Chain Guard Cover Reducer Push Plate Motorbase Plate Motorbase Stiffener Assembly
2	Mainline Drive Spool Shaft (24"-120" LG)		
3	138 Grooved Roller Assembly (138G-BF-D-G1A)		
4	Front Drive Spool Guard 1.5", 3" RC		
5	Drive Spool Guard 1.5", 3" RC (24"-120" LG)	16	
6	796LS Frame Crossbrace	17	1/4" SQ x 7/8" LG Keystock
7	Side Channel 1.5", 3", RC	18	Coupling Assembly (A38222)
8	Lineshaft Pillow Block Bearing (BRW04125)	19	Lineshaft End Kit Assembly End Cover Guard 1/4" X 1/2" Whiz Lock Bolt 1/4" Steel Spring Nut
9	3/8" x 1/2" LG Hex WHFB		
10	Lineshaft Spool (BRW04602)		
11	3/8" x 3/4" LG HHCS	20	Motor
12	3/8" Flange Nut	21	Reducer
13	Spool Spacer (MCW06447)	22	Drive Sprocket (SPW50172)
14	1/8" DIA. x 12-3/4" Drive Band (VBW71382)	23	Reducer Sprocket
15	738 Lineshaft Drive Kit	24	Drive Chain (SPW00500) Connection Link (SPW10500)
	Chain Guard Top Cap		

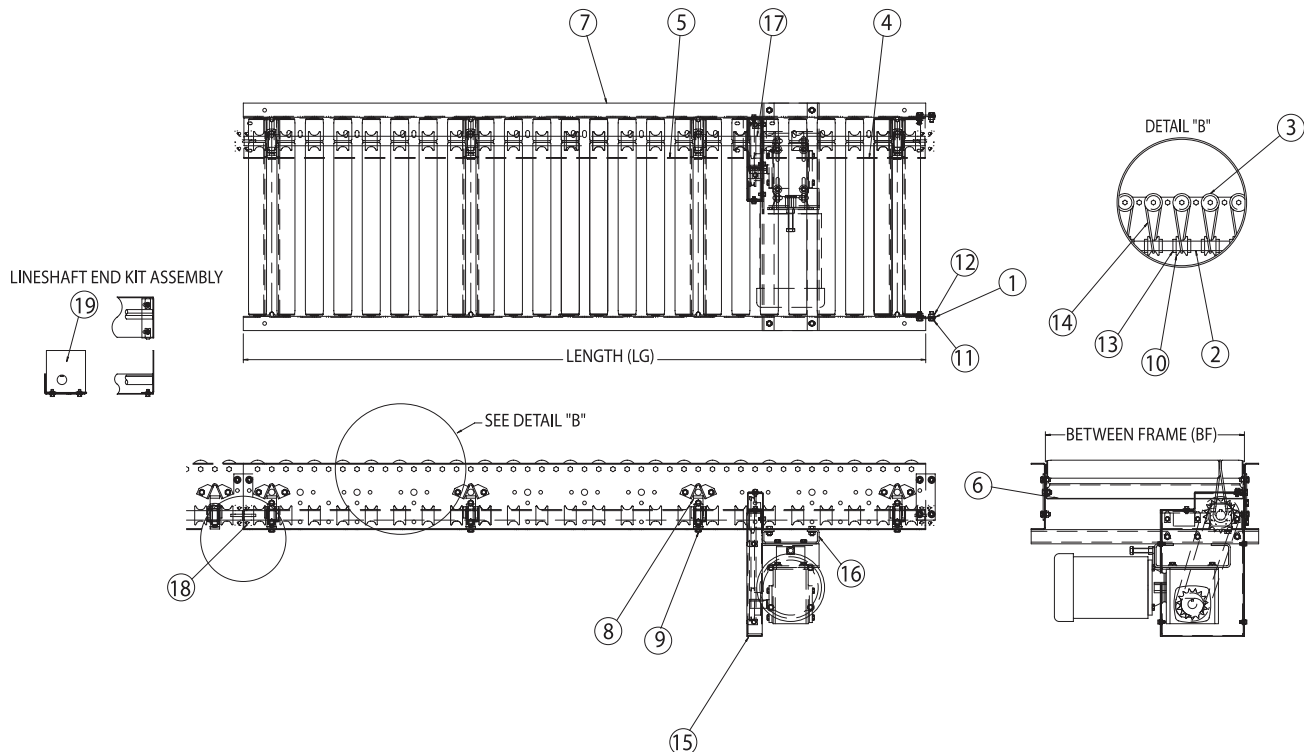

Specify **Unit Serial Number** when ordering replacement parts to ensure proper allocation of components (See Ordering Replacement Parts on page 15).

Recommended Spare Parts are shown in red. Charted are item no. and part description

When ordering use example below.

Example: Need a replacement motor for 738LS With Underneath Mounted Drive

Part No: SN 123456 - 20 - Motor



ROACH CONVEYORS
808 HIGHWAY 463
TRUMANN, AR 72472
TEL 870-483-7631

SERIAL NO. 123456

PARTS LIST FOR LINE SHAFT CONVEYORS INTERMEDIATE 738LSI BED SECTION

ITEM #	DESCRIPTION	ITEM #	DESCRIPTION
1	LS Splice Plate	8	3/8" x 1/2" LG Hex WHFB
2	Mainline Intermediate Spool Shaft (12"-120")	9	Lineshaft Spool (BRW04602)
		10	3/8" x 3/4" LG HHCS
3	138 Grooved Roller Assembly (138G-BF-D-G1A)	11	3/8" Flange Nut
4	Intermediate Spool Guard 1.5", 3" RC (12"-120")	12	Spool SPacer (MCW06447)
		13	1/8" DIA. x 12-3/4" Drive Band (VBW71382)
		14	Coupling Assembly (A38222)
5	796LS Frame Crossbrace	15	Lineshaft End Kit Assembly End Cover Guard 1/4" x 1/2" Whiz Lock Bolt 1/4" Steel Spring Nut
6	Side Channel 1.5", 3" RC		
7	Lineshaft Pillow Block Bearing (BRW04125)		

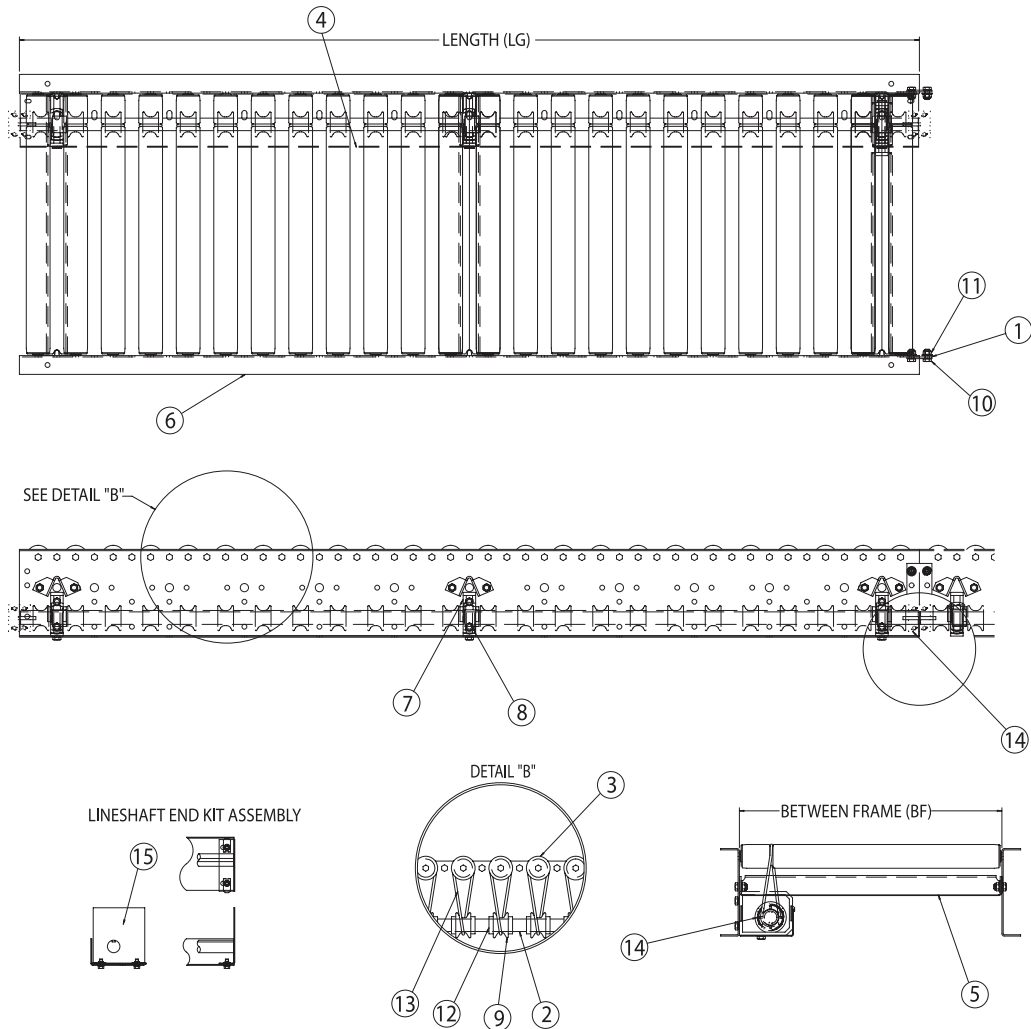

Specify **Unit Serial Number** when ordering replacement parts to ensure proper allocation of components (See Ordering Replacement Parts on page 15).

Recommended Spare Parts are shown in red. Charted are item no. and part description

When ordering use example below.

Example: Need a replacement 138 Grooved Roller Assembly (138G-BF-D-G1A)

Part No: SN 123456 - 3 - 138 Grooved Roller Assembly (138G-BF-D-G1A)



ROACH CONVEYORS
808 HIGHWAY 463
TRUMANN, AR 72472
TEL 870-483-7631

SERIAL NO. 123456

PARTS LIST FOR LINE SHAFT CONVEYORS

796LSC 30° CURVE MODULE

ITEM #	DESCRIPTION	ITEM #	DESCRIPTION
1	U-Joint Cover R.H.	17	LS Bearing PYLSB-9A 1" Bore (BRW04125)
2	U-Joint Cover L.H.	18	3/8"-16 x 1/2" LG. HWHFB
3	Spool Guard Mounting Angle	19	Line shaft Keyed Spool (BRW04604)
4	LS Splice Plate	20	Spool Spacer (MCW06447)
5	End Shaft (Left/Right Hand Side)	21	1/4"-20 x 1/2" Whiz Lock Screw
6	Center Shaft (6-1/4" LG.) Center Shaft (7-5/8" LG.)	22	1/4" Steel Spring Nut
		23	1/4" Flat Washer
7	Curve Spool Guard	24	3/8" x 3/4" LG. HHCS
8	Interm. Spool Guard (Left/Right Hand Side)	25	3/8" Flanged Nylon Insert Nut
9	Double Grooved Tapered Roller (A27057-BF)	26	3/16" Dia. x 13" LG Belt, Clear (VBW71364)
10	196S Single Grooved Roller (A37089-BF)	27	3/16" Dia. x 9-1/4" LG Belt, Blue (VBW71366)
11	LS Frame Crossbrace	28	Line Shaft Spool (BRW04602)
12	Tangent Side Channel (Left/Right Hand Side)	29	Coupling Assembly (A38222)
13	30° Inside Channel 13"-27" 30° Inside Channel 31"-39"	30	Lineshaft End Kit Assembly End Cover Guard 1/4"-20 x 1/2" Whiz Lock Nut 1/4" Steel Spring Nut
14	30° Outside Channel 13"-39"		
15	Universal Joint (MCW06671)		
16	1/4" SQ. x 7/8" LG. Keystock		

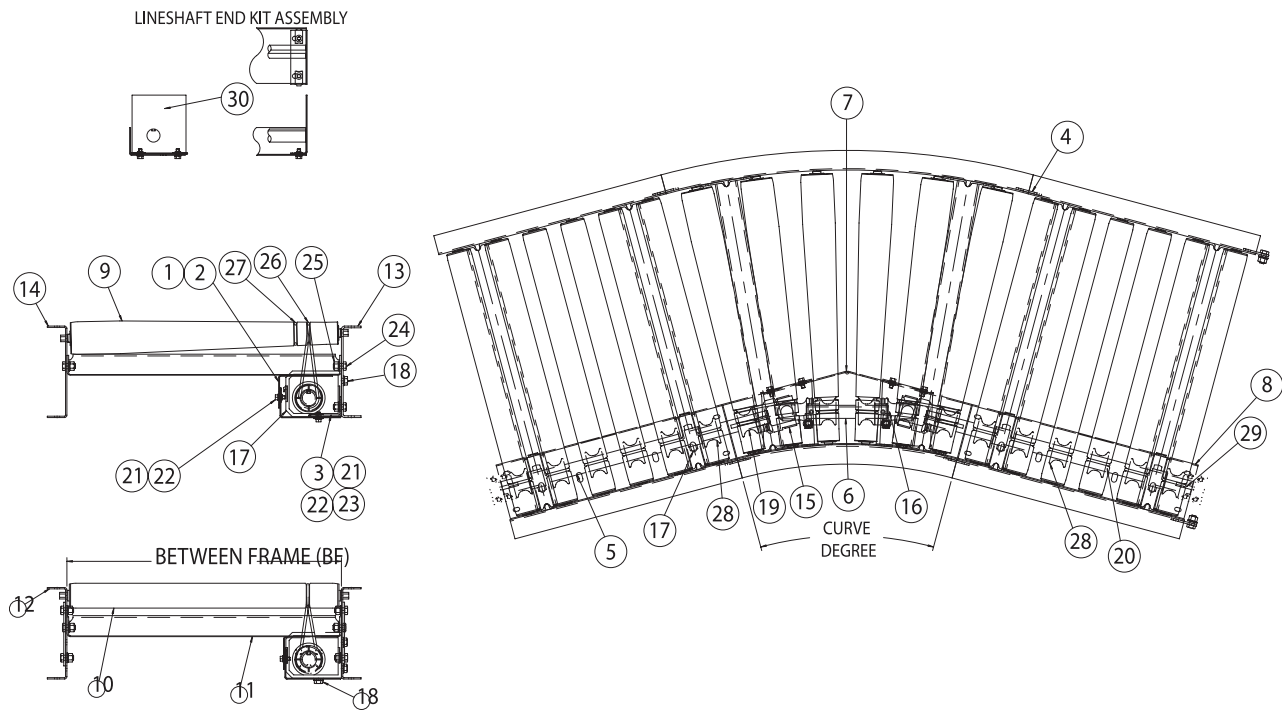

Specify **Unit Serial Number** when ordering replacement parts to ensure proper allocation of components (See Ordering Replacement Parts on page 15).
Recommended Spare Parts are shown in red. Charted are item no. and part description
 When ordering use example below.

Example: Need a replacement End Shaft Left Side for a 796LSC 30° Curve Model
 Part No: SN 123456 - 5 - End Shaft Left Side



ROACH CONVEYORS
808 HIGHWAY 463
TRUMANN, AR 72472
TEL. 870-483-7631

SERIAL NO. 123456

PARTS LIST FOR LINE SHAFT CONVEYORS

796LSC 45° CURVE MODULE

ITEM #	DESCRIPTION	ITEM #	DESCRIPTION
1	U-Joint Cover R.H.	17	LS Bearing PYLSB-9A 1" Bore (BRW04125)
2	U-Joint Cover L.H.	18	3/8"-16 x 1/2" LG. HWHFB
3	Spool Guard Mounting Angle	19	Line shaft Keyed Spool (BRW04604)
4	LS Splice Plate	20	Spool Spacer (MCW06447)
5	End Shaft (Left/Right Hand Side)	21	1/4"-20 x 1/2" Whiz Lock Screw
6	Center Shaft (9-1/2" LG.)	22	1/4" Steel Spring Nut
	Center Shaft (18-3/4" LG.)	23	1/4" Flat Washer
7	Curve Spool Guard	24	3/8" x 3/4" LG. HHCS
8	Interm. Spool Guard (Left/Right Hand Side)	25	3/8" Flanged Nylon Insert Nut
9	Double Grooved Tapered Roller (A27057-BF)	26	3/16" Dia. x 13" LG Belt, Clear (VBW71364)
10	196S Single Grooved Roller (A37089-BF)	27	3/16" Dia. x 9-1/4" LG Belt, Blue (VBW71366)
11	LS Frame Crossbrace	28	Line Shaft Spool (BRW04602)
12	Tangent Side Channel (Left/Right Hand Side)	29	Coupling Assembly (A38222)
13	45° Inside Channel 13"-27"	30	Lineshaft End Kit Assembly End Cover Guard 1/4"-20 x 1/2" Whiz Lock Nut 1/4" Steel Spring Nut
	45° Inside Channel 31"-39"		
14	45° Outside Channel 13"-39"		
15	Universal Joint (MCW06672)		
16	1/4" SQ. x 7/8" LG. Keystock		

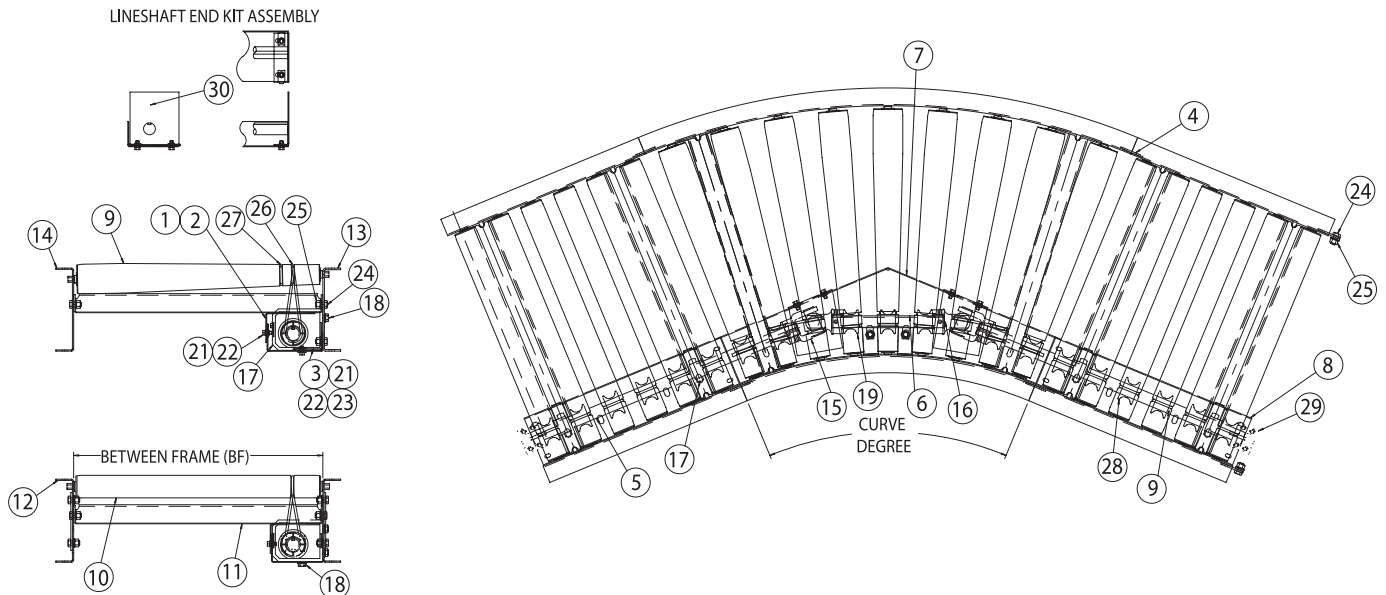

Specify **Unit Serial Number** when ordering replacement parts to ensure proper allocation of components (See Ordering Replacement Parts on page 15).
Recommended Spare Parts are shown in red. Charted are item no. and part description
 When ordering use example below.

Example: Need a replacement End Shaft Right Hand for 796LSC 45° Curve Model
 Part No: SN 123456 - 5 - End Shaft Right Hand



ROACH CONVEYORS
 808 HIGHWAY 463
 TRUMANN, AR 72472
 TEL. 870-483-7631

SERIAL NO. 123456

PARTS LIST FOR LINE SHAFT CONVEYORS

796LSC 60° CURVE MODULE

ITEM #	DESCRIPTION	ITEM #	DESCRIPTION
1	U-Joint Cover R.H.	16	Universal Joint (2 MCW06672)
2	U-Joint Cover L.H.	17	1/4" SQ. x 7/8" LG. Keystock
3	Spool Guard Mounting Angle	18	LS Bearing PYLSB-9A 1" Bore (BRW04125)
4	LS Splice Plate	19	3/8"-16 x 1/2" LG. HWHFB
5	End Shaft (Left/Right Hand Side)	20	Line shaft Keyed Spool (4 BRW04604)
6	Mid Shaft (3-38" LG.) Center Shaft (7-1/8" LG.)	21	Spool Spacer (MCW06447)
		22	1/4"-20 x 1/2" Whiz Lock Screw
7	Center Shaft (12-1/2" LG.) Center Shaft (14-1/2" LG.)	23	1/4" Steel Spring Nut
		24	1/4" Flat Washer
8	Curve Spool Guard	25	3/8" x 3/4" LG. HHCS
9	Interm. Spool Guard (Left/Right Hand Side)	26	3/8" Flanged Nylon Insert Nut
10	Double Grooved Tapered Roller (A27057-BF)	27	3/16" dia. x 13" LG Belt, Clear (VBW71364)
11	196S Single Grooved Roller (A37089-BF)	28	3/16" dia. x 9-1/4" LG Belt, Blue (VBW71366)
12	LS Frame Crossbrace	29	Line Shaft Spool (BRW04602)
13	Tangent Side Channel (Left/Right Hand Side)	30	Coupling Assembly (A38222)
14	60° Inside Channel 13"-27" 60° Inside Channel 31"-39"	31	Lineshaft End Kit Assembly End Cover Guard 1/4"-20 x 1/2" Whiz Lock Nut 1/4" Steel Spring Nut
15	60° Outside Channel 13"-39"		

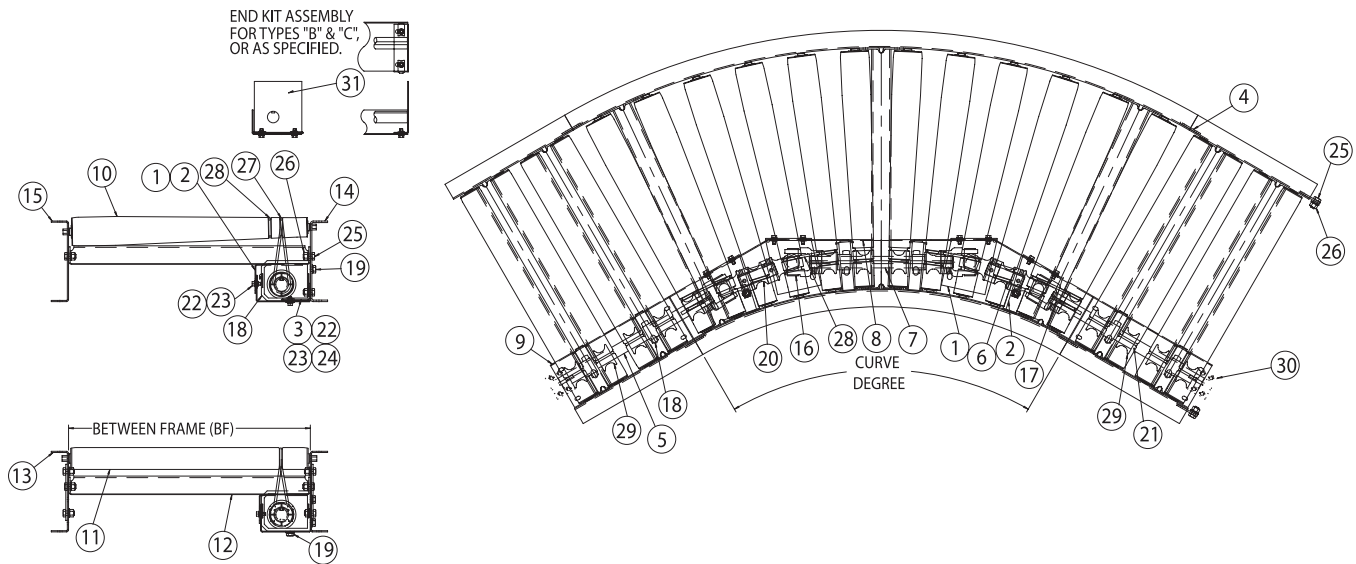

Specify **Unit Serial Number** when ordering replacement parts to ensure proper allocation of components (See Ordering Replacement Parts on page 15).
Recommended Spare Parts are shown in red. Charted are item no. and part description
 When ordering use example below.

Example: Need a replacement End Shaft Right Hand for 796LSC 60°
 Curve Model
 Part No: SN 123456 - 5 - End Shaft Right Hand



ROACH CONVEYORS
 808 HIGHWAY 463
 TRUMANN, AR 72472
 TEL. 870-483-7631

SERIAL NO. 123456

PARTS LIST FOR LINE SHAFT CONVEYORS

796LSC 90° CURVE MODULE

ITEM #	DESCRIPTION	ITEM #	DESCRIPTION
1	U-Joint Cover R.H.	16	Universal Joint (2 MCW06672)
2	U-Joint Cover L.H.	17	1/4" SQ. x 7/8" LG. Keystock
3	Spool Guard Mounting Angle	18	LS Bearing PYLSB-8A 1" Bore (BRW04125)
4	LS Splice Plate	19	3/8"-16 x 1/2" LG. HWHFB
5	End Shaft (Left/Right Hand Side)	20	Line shaft Keyed Spool (4 BRW04604)
6	Mid Shaft (9-1/2" LG.) Center Shaft (16-7/8" LG.)	21	Spool Spacer (7 MCW06447)
		22	1/4"-20 x 1/2" Whiz Lock Screw
7	Center Shaft (12-1/2" LG.) Center Shaft (18-7/8" LG.)	23	1/4" Steel Spring Nut
		24	1/4" Flat Washer
		25	3/8" x 3/4" LG. HHCS
8	Curve Spool Guard	26	3/8" Flanged Nylon Insert Nut
9	Interm. Spool Guard (Left/Right Hand Side)	27	3/16" Dia. x 13" LG Belt, Clear (VBW71364)
10	Double Grooved Tapered Roller (A27057-BF)	28	3/16" Dia. x 9-1/4" LG Belt, Blue (VBW71366)
11	196S Single Grooved Roller (A37089-BF)	29	Line Shaft Spool (VBW71366)
12	LS Frame Crossbrace	30	Coupling Assembly (A38222)
13	Tangent Side Channel (Left/Right Hand Side)	31	Lineshaft End Kit Assembly End Cover Guard 1/4"-20 x 1/2" Whiz Lock Nut 1/4" Steel Spring Nut
14	90° Inside Channel 13"-27" 45° Inside Channel 31"-39"		
15	90° Outside Channel 13"-27" 45° Outside Channel 13"-39"		

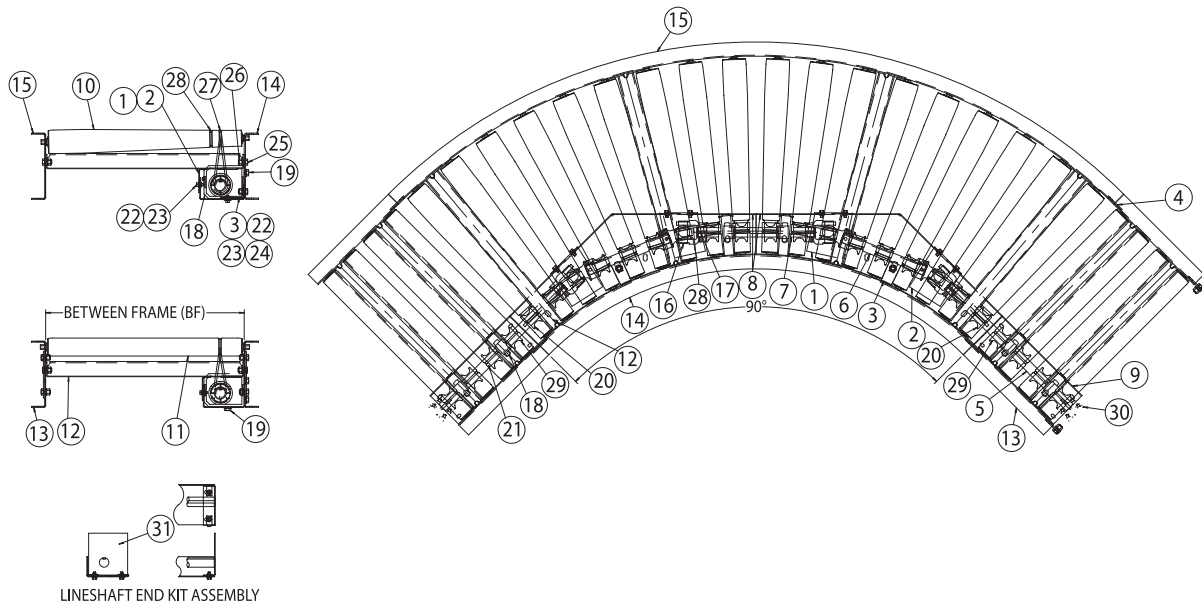

Specify **Unit Serial Number** when ordering replacement parts to ensure proper allocation of components (See Ordering Replacement Parts on page 15).
Recommended Spare Parts are shown in red. Charted are item no. and part description
 When ordering use example below.

Example: Need a replacement End Shaft Left Hand for 796LSC 90° Curve Model
 Part No: SN 123456 - 5 - End Shaft Left Hand

ROACH CONVEYORS
808 HIGHWAY 463
TRUMANN, AR 72472
TEL. 870-483-7631

SERIAL NO. 123456

PARTS LIST FOR LINE SHAFT CONVEYORS

796LSC 180° CURVE MODULE 13-27 BF

ITEM #	DESCRIPTION	ITEM #	DESCRIPTION
1	U-Joint Cover R.H.	19	Universal Joint (MCW06672)
2	U-Joint Cover L.H.	20	1/4" SQ. x 7/8" LG. Keystock
3	Spool Guard Mounting Angle	21	LS Bearing PYLSB-8A 1" Bore
4	LS Splice Plate	22	3/8"-16 x 1/2" LG. HWHFB
5	End Shaft (18-1/4" LG.)	23	Line shaft Keyed Spool (BRW04604)
6	Mid shaft (99-1/2" LG.)	24	Spool Spacer (MCW06447)
7	Mid Shaft of 90° (12-1/2" LG.)	25	1/4"-20 x 1/2" Whiz Lock Screw
8	Center Shaft (12-3/4" LG.)	26	1/4" Steel Spring Nut
	Center Shaft (24-3/4" LG.)	27	1/4" Flat Washer
	Center Shaft (30-3/4" LG.)		
9	Curve Spool Guard	28	3/8" x 3/4" LG. HHCS
10	Interm. Spool Guard 12"	29	3/8" Flanged Nylon Insert Nut
11	Ctr. Intermediate Spool Guard 12" Ctr. Intermediate Spool Guard 18"	30	3/16" Dia. x 13" LG Belt, Clear (VBW71364)
12	Double Grooved Tapered Roller (A27057-BF)	31	3/16" Dia. x 9-1/4" LG Belt, Blue (VBW71366)
13	196S Single Grooved Roller (A37089-BF)	32	Line Shaft Spool (BRW04602)
14	LS Frame Crossbrace	33	Coupling Assembly (A38222)
15	Tangent Side Channel 12" LG	34	Lineshaft End Kit Assembly End Cover Guard 1/4"-20 x 1/2" Whiz Lock Nut 1/4" Steel Spring Nut
16	Ctr. Tangent Side Channel 12" LG. & 18" LG.		
17	90° Inside Channel 13"-27"		
18	90° Outside Channel 13"-27"		

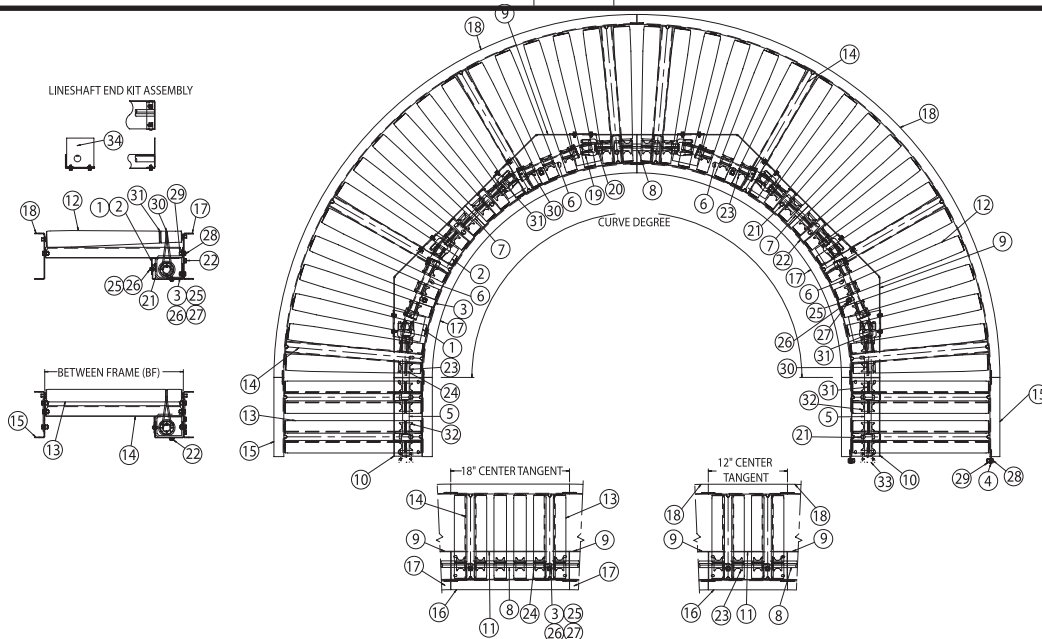

Specify **Unit Serial Number** when ordering replacement parts to ensure proper allocation of components (See Ordering Replacement Parts on page 15).
Recommended Spare Parts are shown in red. Charted are item no. and part description
 When ordering use example below.

Example: Need a replacement End Shaft for 796LSC 180°
 Curve Model 13-27 BF
 Part No: SN 123456 - 5 - End Shaft



ROACH CONVEYORS
 808 HIGHWAY 463
 TRUMANN, AR 72472
 TEL. 870-483-7631

SERIAL NO. 123456

PARTS LIST FOR LINE SHAFT CONVEYORS

796LSC 180° CURVE MODULE 31-39 BF

ITEM #	DESCRIPTION	ITEM #	DESCRIPTION
1	U-Joint Cover R.H.	19	45° Outside Channel 31"-39"
2	U-Joint Cover L.H.	20	Universal Joint (2 MCW06672)
3	Spool Guard Mounting Angle	21	1/4" SQ. x 7/8" LG. Keystock
4	LS Splice Plate	22	1/4" SQ. x 1-1/2" LG. Keystock
5	End Shaft (20" LG.)	23	Modified Shaft Coupling (S12763)
6	Mid shaft 16-7/8" LG.	24	Shipping Angle
7	Mid Shaft of 90° (18-7/8" LG.)	25	Shipping Angle
8	Center Shaft (8" LG.) Right Side	26	LS Bearing PYLSB-8A 1" Bore (BRW04125)
		27	3/8"-16 x 1/2" LG. HWHFB
9	Center Shaft (8" LG.) Left Side Center Shaft (20" LG.) Left Side Center Shaft (26" LG.) Left Side	28	Line shaft Keyed Spool (4 BRW04604)
		29	Spool Spacer (7 MCW06447)
		30	1/4"-20 x 1/2" Whiz Lock Screw
10	Curve Spool Guard	31	1/4" Steel Spring Nut
11	Intermediate Spool Guard 12"	32	1/4" Flat Washer
12	Ctr. Intermediate Spool Guard 12" Ctr. Intermediate Spool Guard 18"	33	3/8" x 3/4" LG. HHCS
		34	3/8" Flanged Nylon Insert Nut
13	Double Grooved Tapered Roller (A27057-BF)	35	3/16" Dia. x 13" LG Belt, Clear (VBW71364)
14	196S Single Grooved Roller (A37089-BF)	36	3/16" Dia. x 9-1/4" LG Belt, Blue (VBW71366)
15	LS Frame Crossbrace	37	Line Shaft Spool (2 BRW04602)
16	Tangent Side Channel 12" LG	38	Coupling Assembly (A38222)
17	Ctr. Tangent Side Channel 12" LG. & 18" LG.	39	Lineshaft End Kit Assembly End Cover Guard 1/4"-20 x 1/2" Whiz Lock Nut 1/4" Steel Spring Nut
18	45° Inside Channel 31"-39"		

Specify **Unit Serial Number** when ordering replacement parts to ensure proper allocation of components (See Ordering Replacement Parts on page 15).
Recommended Spare Parts are shown in red. **Charted** are item no. and part description.

When ordering use example below.

Example: Need a replacement End Shaft for
 796LSC 180° Curve Model 31-39 BF
 Part No: SN 123456 - 5 - End Shaft

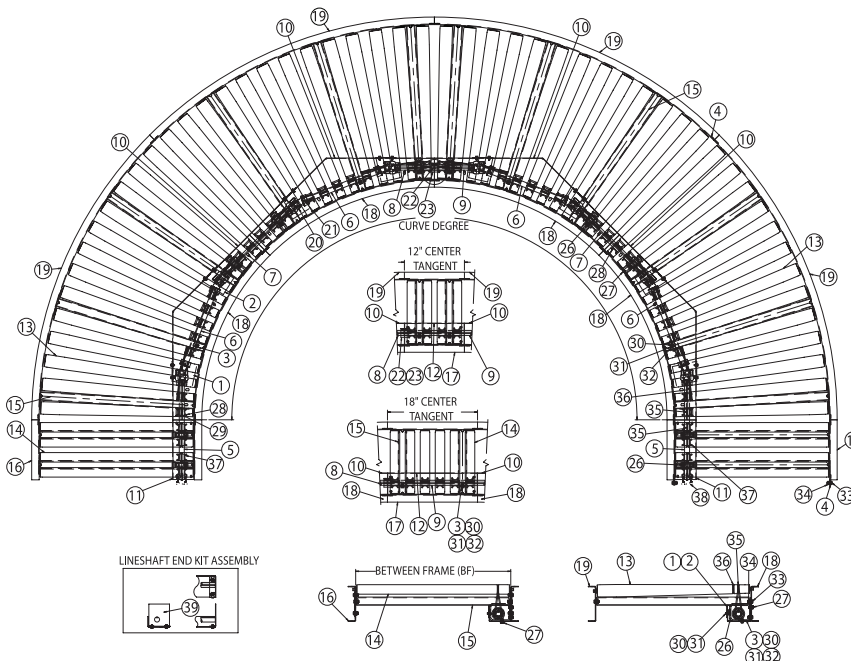

ROACH CONVEYORS
 808 HIGHWAY 463
 TRUMANN, AR 72472
 TEL 870-483-7631

SERIAL NO. 123456

PARTS LIST FOR LINE SHAFT CONVEYORS

796LSS LINE SHAFT SPUR MODULE

ITEM #	DESCRIPTION	ITEM #	DESCRIPTION
1	Side Channel	22	Spool Spacer (MCW06447)
1A	Spur side Channel w/Cutout	23	Mainline Spool Guard
2	Crossbrace	24	U-Joint Bottom Guard
3	196S Grooved Roller (A37089-BF)	25	30° Spur Spool Guard
4	30° Spur Frame Weld Assembly		45° spur Spool Guard
5	30° Roller Retainer Bracket	26	Top Crossover Chain Guard
5A	5/16"-18 x 3/4" Carriage Bolt	27	Bottom Crossover Chain Guard
5B	5/16"-18 Flange Hex Nut	27A	Bottom End Plate
6	30° 196S Shortened Spur Rollers (contact Factory)	28	1/4"-20 x 1/2" Whiz Lock Screw
	196S Pinned Roller (Contact Factory)	29	1/4" Spring nut
	1/8" x 1" Cotter Pin (FSW09957-01)	30	LS Splice Plate
7	45° Spur Frame Weld Assembly	31	3/16" DIA. x 13" Drive Band (VWB71364)
8	45° Roller Retainer Bracket	32	H40B-16 Crossover Sprocket (SPW21616-01)
8A	5/16"-18 x 3/4" Carriage Bolt	33	#40 Roller Chain (SPW00400)
7B	5/16"-18 Flange Hex Nut	34	1/4" square x 7/8" Keystock
9	45° 196S shortened Spur Rollers (contact Factory)	35	1/4" square x 2-1/8" Keystock
	196S Pinned Roller (Contact Factory)	36	3/8"-16 x 3/4" HHCS
	1/8" x 1" Cotter Pin (FSW09957-01)	37	3/8"-16 Flange Nut
10	Spur Mounting Bracket	38	Spool Guard Mounting Angle
11	3/8"-16 x 3/4" Carriage Screw	39	Wearstrip Mounting Angle Chain Wearstrip 1/4"-2 0 x 3/4" FHSMS 1/4" Flange Nut 5/16"-18 x 3/4" Carriage Bolt 5/16"-18 Flange Hex Nut
12	Mainline Shaft (72, 96, 120 OAL)		
13	30° Spur Drive Shaft 45° Spur Drive Shaft		
14	30° Spur Shaft 45° Spur Shaft		
15	Stub Shaft	40	U-Joint Top guard LSS
16	Single Universal Joint (MCW06672)	41	Lineshaft Keyed Spool (BRW04604)
17	PYLSB-8A 1" Bore (BRW04125)	42	Crossover Spool Guard
18	3/8" x 1/2" LG Hex WHFB	43	Coupling Assembly (A38222)
21	Lineshaft Spool (BRW04602)	44	Lineshaft end Kit Assembly End Cover Guard 1/4" x 1/2" Whiz Lock Bolt 1/4" steel Spring Nut

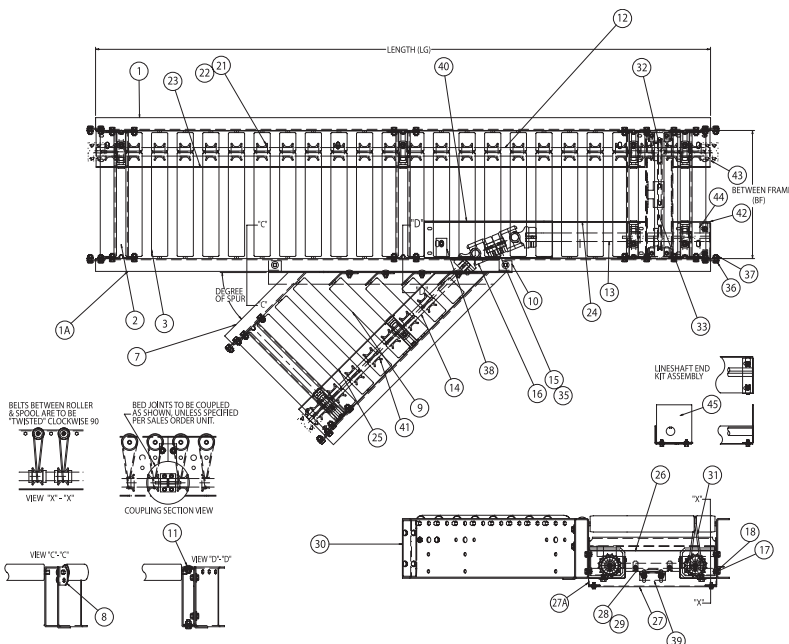

Specify **Unit Serial Number** when ordering replacement parts to ensure proper allocation of components (See Ordering Replacement Parts on page 15).

Recommended Spare Parts are shown in red. Charted are item no. and part description

When ordering use example below.

Example: Need a replacement Side Channel for
796LSS Line Shaft Spur Module
Part No: SN 123456 - 1 - Side Channel



ROACH CONVEYORS
 808 HIGHWAY 463
 TRUMANN, AR 72472
 TEL. 870-483-7631

SERIAL NO. 123456

PARTS LIST FOR LINE SHAFT CONVEYORS

796LSSO LINE SHAFT SPUR ONLY

796LSSOX LINE SHAFT SPUR ONLY WITH CROSS-OVER

ITEM #	DESCRIPTION	ITEM #	DESCRIPTION
1	796LS Crossbrace	20	3/16" dia. x 13" LG Belt, Clear (VBW71364)
2	196S Grooved Roller (A37089-BF)	21	1" I.D. Locking Collar
3	30° Spur Frame Weld Assembly	22	1/4" Square x 7/8" Keystock
4	30° Roller Retainer Bracket	23	H40B-16 Sprocket w/1" Bore
5	5/16"-18 x 3/4" Carriage Bolt	24	#40 Roller Chain (SPW00400)
6	5/16"-18 Flange Hex Nut	25	#40 Roller Chain Connecting Link (SPW10400)
7	30° 196S Shortened Spur Rollers (Contact Factory) 196S Pinned Roller (Contact Factory) 1/8" x 1" Cotter Pin (FSW09957-01)	26	Top Crossover Chain Guard
		27	Bottom Crossover Chain Guard
		28	Bottom End Plate
8	45° Spur Frame Weld Assembly	29	1/4"-20 x 1/2" Whiz Lock Screw
9	45° Roller Retainer Bracket	30	1/4" Spring Nut
10	45° 196S Shortened Spur Rollers (Contact Factory) 196S Pinned Roller (Contact Factory) 1/8" x 1" Cotter Pin (FSW09957-01)	31	Crossover Spool Shaft
		32	Crossover Spool Guard
11	Spur Mounting Bracket	33	Wearstrip Mounting Angle Chain Wearstrip 1/4"-20 x 3/4" FHSMS 5/16"-18 Flange Hex Nut
12	3/8"-16 x 3/4" Carriage Screw		
13	30° Spur Shaft 40° Spur Shaft		
14	PYLSA-8A 1" Bore LS Brg (BRW04125)	34	Spool Guard Mounting Angle 1/4" Flat Washer
15	3/8-16 x 1/2" LG HWH Serr Bolt	35	Coupling Assembly (A38222)
16	Lineshaft Keyed Spool	36	Lineshaft End Kit Assembly End Cover Guard 1/4" x 1/2" Whiz Lock Bolt 1/4" Steel Spring Nut
17	Spool Spacer (MCW06447)		
18	30° Spur Spool Guard 45° Spur Spool Guard		
19	Splice Plates		

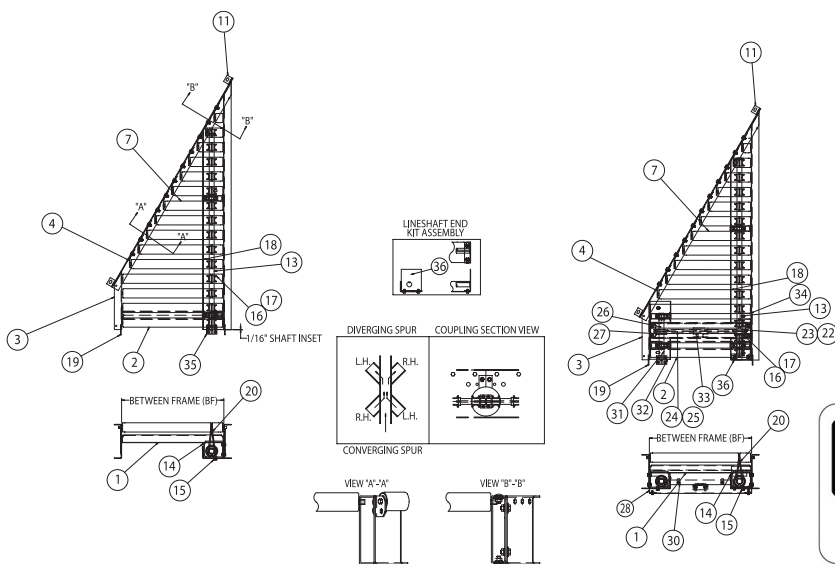

Specify **Unit Serial Number** when ordering replacement parts to ensure proper allocation of components (See Ordering Replacement Parts on page 15).
Recommended Spare Parts are shown in red. Charted are item no. and part description
 When ordering use example below.

Example: Need a replacement 196S Grooved Roller for 796LSS0 Line Shaft Spur Only

Part No: SN 123456 - 2 - 196S Grooved Roller



ROACH CONVEYORS
 808 HIGHWAY 463
 TRUMANN, AR 72472
 TEL 870-483-7631

SERIAL NO. 123456

PARTS LIST FOR LINE SHAFT CONVEYORS

796LSG LINE SHAFT GATE MODULE

ITEM #	DESCRIPTION	ITEM #	DESCRIPTION
1	Outside Hinge Weld Assembly	31	1/4" Square x 7/8" Long Keystock
2	Lineshaft Gate Clutch Shaft Assembly (Specify Length)	32	Chain Tension Wearstrip
3	Gas Spring Support Channel Weld Assembly	33	Stop Strap Bushing
4	196S Center Grooved Roller Assembly (A36947-BF)	34	Stationary Spool Shaft
5	Crossbrace Weld Assembly	35	PB-1 Bearing Insert (BRW04111-01)
6	Gate Crossbrace Weld Assembly	36	PB-1 Housing
7	196S Single Grooved Roller Assembly (A37089-BF)	37	LS Bearing PYLSB-8A 1" Bore (BRW04125)
8	Lineshaft Coupling Assembly (A38222)	38	Line Shaft Spool (BRW04602)
9	Lineshaft End Kit Assembly (A38223)	39	1/4"-20 x 1/2" Whiz Lock Bolt
10	Frame Crossbrace	40	3/8"-16 x 1/2" HHWFB
11	Handle	41	3/8"-16 x 3/4" HHCS
12	Chain Tension Wearstrip Mounting Angle	42	3/8"-16 x 1" HHCS
13	Inside Hinge	43	3/8"-16 x 1-1/2" HHCS
14	Gate Side Channel (Specify length)	44	1/4"-20 x 3/4" FHSMS
15	Stationary Side Channel	45	5/16"-18 x 3/4" Carriage Bolt
16	Hinge Spacer	46	1/4"-20 Flange Nut
17	Support Angle	47	1/4" Flat Washer
18	Gate Spool Guard (Specify Length)	48	5/16"-18 Flange Nut
19	Hinge Guard	49	3/8"-16 Nylon Insert Flanged Nut
20	Stop Strap	50	3/8" Flat Washer
21	Gas Spring Mounting Angle	51	3/8"-16 Jam Nut w/Nylon Insert
22	Short Bottom End Plate	52	1/2" x 1/2" x 3/8"-16 Shoulder Bolt
23	Gas Spring Mounting Bracket	53	1/2" x 3/4" x 3/8"-16 Shoulder Bolt
24	Center Shaft Guard	54	1/4" Spring Nut
25	Stationary Spool Guard	55	1/2" Flat Washer
26	Top Crossover Chain Guard	56	Spool Spacer (MCW06447)
27	Bottom Crossover Chain Guard	57	IGS #14-8-21.66-MBI-MBI- Gas Spring (Contact Factory)
28	Spool Guard Mounting Angle	58	#40 Chain (Crossover)
29	LS Splice Plate	59	#40 Connecting Link
30	Bottom End Plate	60	H40B16 Sprocket (Crossover)
		61	3/16" Dia. x 13" Long Clear Belt (YBW71364)

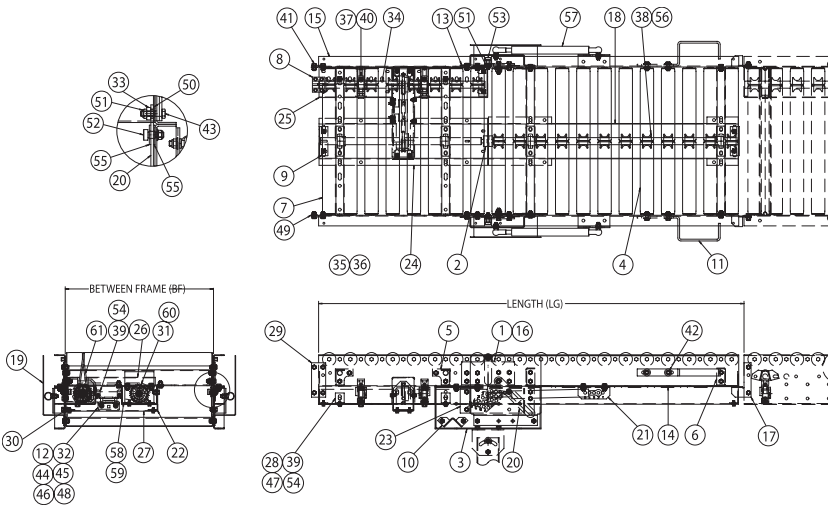

Specify **Unit Serial Number** when ordering replacement parts to ensure proper allocation of components (See Ordering Replacement Parts on page 15).

Recommended Spare Parts are shown in red. Charted are item no. and part description

When ordering use example below.

Example: Need a replacement Spool Spacer (MCW06447) for a 796LSG Line Shaft Gate Module

Part No: SN 123456 - 56 - Spool SPacer



ROACH CONVEYORS
 808 HIGHWAY 463
 TRUMANN, AR 72472
 TEL. 870-483-7631

SERIAL NO. 123456

PARTS LIST FOR LINE SHAFT CONVEYORS

796LSX LINE SHAFT CROSS-OVER MODULE

ITEM #	DESCRIPTION	ITEM #	DESCRIPTION
1	LS Splice Plate	22	Wearstrip Mounting Angle
2	Lineshaft Pillow Block Bearing (BRW04125)	23	Chain Wearstrip 1/4"-20 x 3/4" FHSMS 1/4"-20 Flanged Nut 5/16"-18 x 3/4" Carriage Bolt 5/16"-18 Flanged Nut
3	3/16" Dia. x 13" Drive Band (VBW71364)		
4	Side Channel 3", 4", 6" RC		
5	796LS Frame Crossbrace		
6	Mainline Drive w/Crossover Shaft		
7	Crossover Spool Shaft 3", 4", 6" RC	24	3/8"-16 x 1/2" Hex WHFB
8	Lineshaft Spool	25	796 Lineshaft Drive Kit Chain Guard Top Cap Chain Guard Top Cover Chain Guard Filler Chain Guard Cover Reducer Push Plate Motor Base Plate Motor Base Stiffener Assembly
9	Spool Spacer (MCW06447)		
10	196 Grooved Roller Assembly (A37089-BF)		
11	Crossover Spool Guard 3", 4", 6" RC		
12	Top Crossover Chain Guard		
13	Bottom Crossover Chain Guard		
14	Bottom End Plate		
15	Drive Spool Guard 3", 6" RC 24" OAL SAect. - 120" Sect. Drive Spool Guard 4" RC	26	Reducer Spacer Channel
16	3/8" x 3/4" HHCS	27	Crossover Motorbase Spool Guard 3", 4", 6" RC
17	3/8" Flange Nut	28	1/4" SQ x 7/8" LG. Keystock
18	1/4" x 1/2" Whiz Lock Bolt	29	Coupling Assembly (A38222)
19	1/4" Spring Nut	30	Lineshaft End Kit Assembly End Cover Guard 1/4" x 1/2" Whiz Lock Bolt 1/4" Steel Spring Nut
20	H40B16 Crossover Sprocket (616-01)		
21	#40 Chain (Crossover) (SPW00400)		

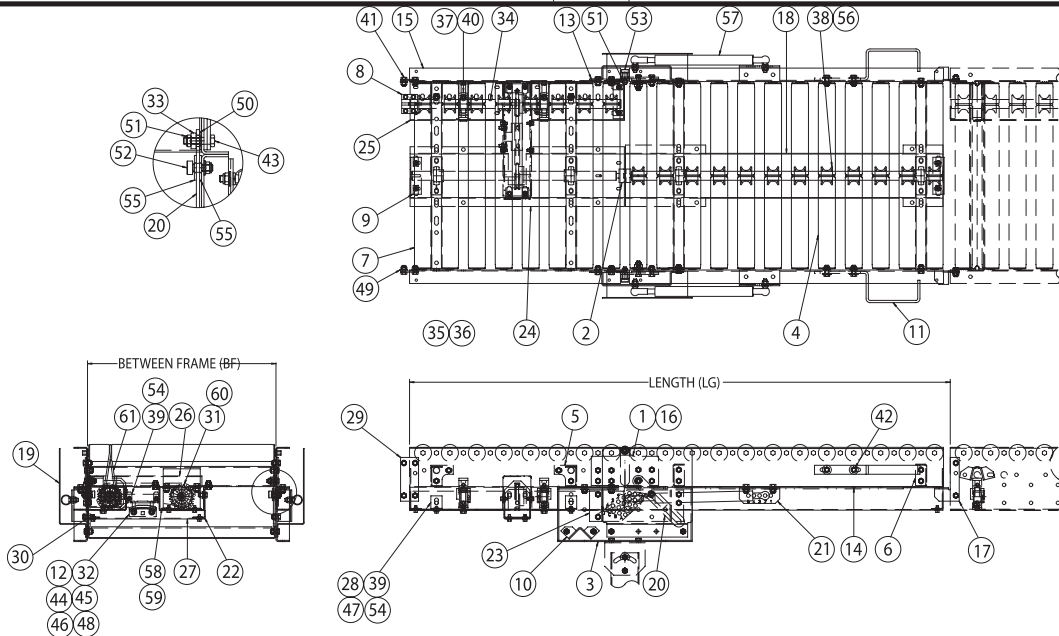

Specify **Unit Serial Number** when ordering replacement parts to ensure proper allocation of components (See Ordering Replacement Parts on page 15).

Recommended Spare Parts are shown in red. Charted are item no. and part description

When ordering use example below.

Example: Need a replacement Coupling Assembly (A38222) for a 796LSX Line Shaft Cross-Over Module

Part No: SN 123456 - 29 - Coupling Assembly



ROACH CONVEYORS
808 HIGHWAY 463
TRUMANN, AR 72472
TEL. 870-483-7631

SERIAL NO. 123456

PARTS LIST FOR LINE SHAFT CONVEYORS

796LSIX LINE SHAFT CROSS-OVER INTERMEDIATE MODULE

ITEM #	DESCRIPTION	ITEM #	DESCRIPTION
1	LS Splice Plate	18	1/4" x 1/2" Whiz Lock Bolt
2	Lineshaft Pillow Block Bearing (BRW04125)	19	1/4" Spring Nut
3	3/16" Dia. X 13" Drive Bank (VBW71364)	20	H40B16 Crossover Sprocket (SPW21616-01)
4	Side Channel 3", 4", 6" RC	21	#40 Chain (Crossover)
5	796LS Frame Crossbrace	22	Spool Guard Mounting Angle
6	Mainline Intermediate Spool Shaft w/Crossover (12"-120" LG)	23	Wearstrip Mounting Angle
7	Crossover Spool Shaft 3", 4", 6" RC	24	Chain Wearstrip 1/4"-20 x 3/4" FHSM 1/4"-20 Flanged nut 5/16"-18 x 3/4" Carriage Bolt 5/16"-18 Flanged Nut
8	Lineshaft Spool (BRW04602)		
9	Spool SPacer (MCW06447)		
10	196 Grooved Roller Assembly (A37089-BF)	25	3/8"-16 x 1/2" Hex WHFB
11	Crossover Spool Guard 3", 4", 6" RC	26	1/4" Flat Washer
12	Top Crossover Chain Guard	27	1/4" SQ. X 7/8" Lg. Keystock
13	Bottom Crossover Chain Guard	28	Coupling Assembly (A38222)
14	Bottom End Plate	29	Lineshaft End Kit Assembly
15	796LSXI Spool Guard 3", 4" 6" RC		End Cover Guard
16	3/8" X 3/4" HHCS		1/4" x 1/2" Whiz Lock Bolt
17	3/8" Flange Nut		1/4" Steel Spring Nut

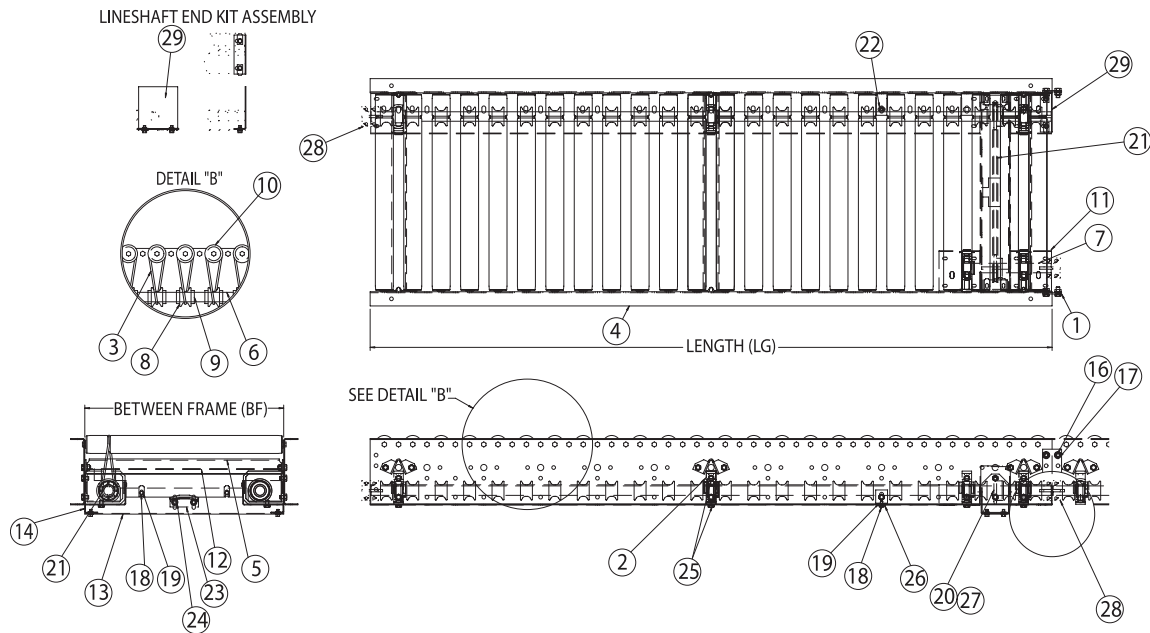

Specify **Unit Serial Number** when ordering replacement parts to ensure proper allocation of components (See Ordering Replacement Parts on page 15).
Recommended Spare Parts are shown in red. Charted are item no. and part description
 When ordering use example below.

Example: Need a replacement LS Splice Plate for 796LSXI Line Shaft Cross-Over Intermediate Module
 Part No: SN 123456 - 1 - LS Splice Plate



ROACH CONVEYORS
808 HIGHWAY 463
TRUMANN, AR 72472
TEL 870-483-7631

SERIAL NO. 123456



ROACH CONVEYORS

WARRANTY

- **Materials used by Roach Conveyors are of good quality.**
- **Any part proving to be defective in materials or workmanship upon Roach inspection, will be replaced at NO cost, FOB, Trumann, Arkansas, for one year. Installation expense will be paid by others.**
- **Roach liability includes furnishing said part or parts; Roach is not liable for consequential damages, such as loss of profit, delays or expenses incurred by failure of said part or parts.**
- **Failure due to abuse, incorrect adjustments, exposure to corrosive or abrasive environment or operation under damp conditions does not constitute failure due to defects in workmanship or materials.**
- **Component parts not manufactured by Roach (motors, gear reducers, etc.) will be repaired or replaced at the option of their manufacturer. Contact nearest authorized service center for all warranty claims.**

NOTE: Motors or gear reducers tampered with before inspection shall be considered free of ALL Warranty Claims.

**--All specifications are subject to change without notice--
--Drawings are intended for illustration ONLY and are not to scale--**

**808 HIGHWAY 463
TRUMANN, ARKANSAS 72472-1310
Tel 870-483-7631 Fax 870-483-7049
info@roachconveyors.com
www.roachconveyors.com**



ROACH
C O N V E Y O R S ®

808 HIGHWAY 463
TRUMANN, ARKANSAS 72472-1310
Tel 870-483-7631 Fax 870-483-7049
info@roachconveyors.com
www.roachconveyors.com