

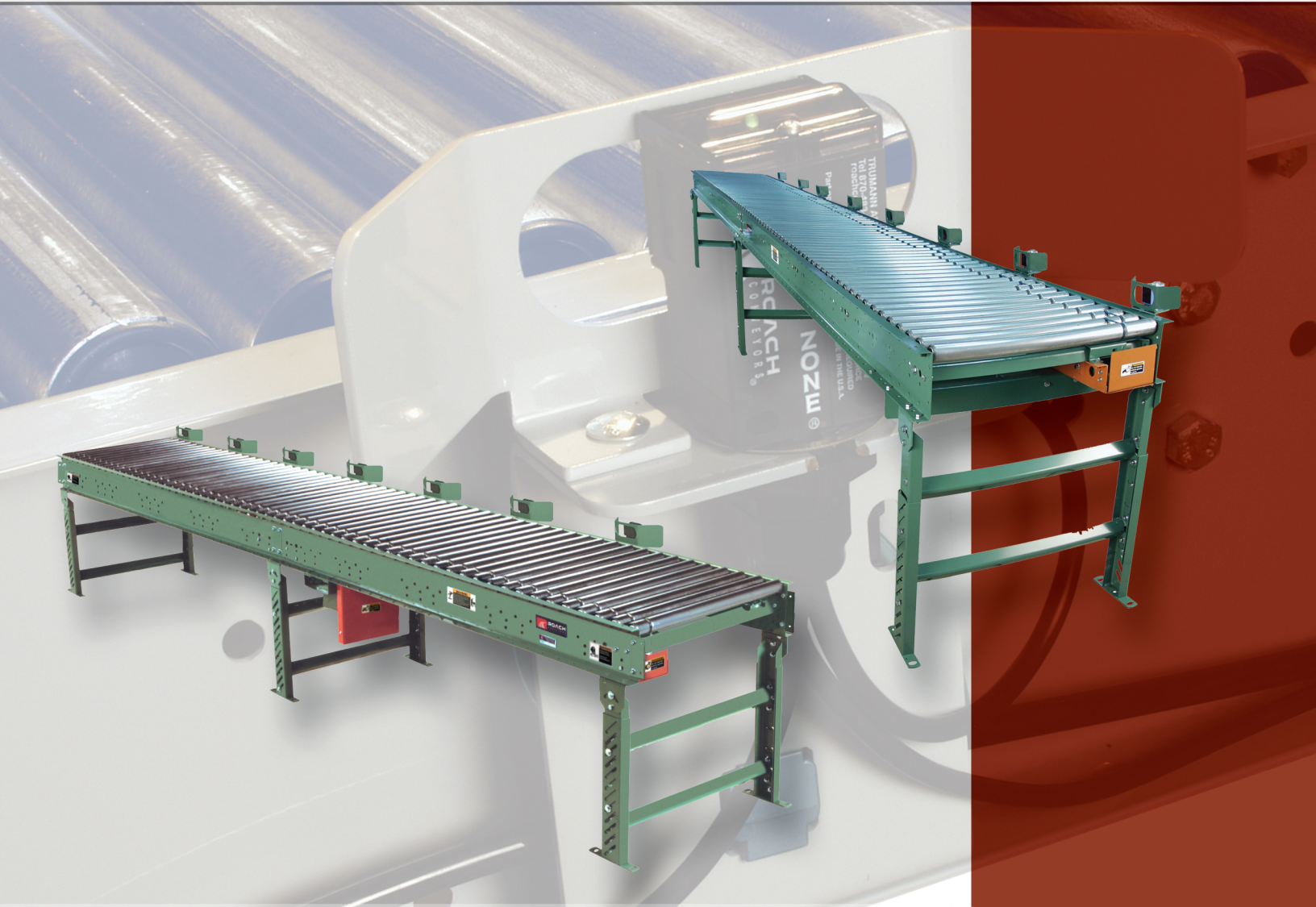

# OWNER'S MANUAL



## Smart Zone<sup>®</sup> Line Shaft Accumulators

Models SZ738LSZ • SZ796LSZ

DO NOT OPERATE BEFORE READING THIS HANDBOOK  
KEEP IN A SAFE PLACE – DO NOT DISCARD

# TECH HANDBOOK FOR LINE SHAFT CONVEYORS

## TABLE OF CONTENTS

LINE SHAFT CONVEYOR TECH HANDBOOK.....	2	-Report on Miscellaneous Maintenance Performed .....	14
-Caution Labels.....	2	TRUBLE SHOOTING AND REPLACEMENT PARTS .....	15
CAUTIONS, WARNINGS AND HAZARDS.....	3	-Trouble Shooting / Serial Plate.....	15
-Introduction .....	3	TECHNICAL - SMART ZONE®.....	16
-Cautions, Warnings and Hazards.....	3	-Smart Zone® Operation .....	16
SAFETY INFORMATION, ABOUT LINE SHAFT CONV.....	4	-Smart Zone® Details.....	16
-Important Safety Guidelines.....	4	-Smart Zone® Offloading.....	17
-About Line Shaft Conveyor.....	4	-Smart Zone® Slug Release Offloading / Slug Loading .....	17
RECEIVING AND INSPECTION.....	5	PARTS LISTS FOR LINE SHAFT CONVEYORS.....	18
-Shortages, Damages and Return Authorizations.....	5	-Parts List for SZ738LSZ Bed Section 1.5" Rollers .....	18
-Uncrating.....	5	-Parts Drawing for SZ738LSZ Bed Section 1.5" Rollers .....	19
GENERAL INSTALLATION INFORMATION.....	6	-Parts List for SZ738LSZ Bed Section 3" Rollers .....	20
-Coupling/Shaft End Cover Allocation.....	6	-Parts Drawing for SZ738LSZ Bed Section 3" Rollers .....	21
-Preparing for Setup .....	6	-Parts List for SZ738LSZI Bed Section 1.5" Rollers.....	22
-Attaching Bed Sections and Shaft Couplings .....	7	-Parts Drawing for SZ738LSZI Bed Section 1.5" Rollers.....	23
-Identifying / Installing Permanent Floor Supports .....	8	-Parts List for SZ738LSZI Bed Section 3" Rollers.....	24
-Installation of Polytier Supports .....	8	-Parts Drawing for SZ738LSZI Bed Section 3" Rollers.....	25
-Installing Knee braces and Casters.....	9	-Parts List for SZ796LSZ Bed.....	26
-Installation of Ceiling Hangers.....	9	-Parts Drawing for SZ796LSZ Bed.....	27
START-UP PROCEDURES .....	10	-Parts List for SZ796LSZI Bed.....	28
-Drive Chain and Sprocket Alignment.....	10	-Parts Drawing for SZ796LSZI Bed.....	29
-Drive Chain and Sprocket Tension .....	10	NOTES .....	30
-Gear Reducer with Posivent® .....	11	WARRANTY .....	31
-Preparing for Initial Start-Up .....	11		
MAINTENANCE SAFETY PRECAUTIONS .....	12		
-Before Performing Maintenance .....	12		
-Maintenance and Follow-Up Details .....	12		
MAINTENANCE AND LUBRICATION .....	13		
-Periodic Maintenance Schedule.....	13		
-Recommended Lubricants .....	14		

## CAUTION LABELS



ABOVE: Label attached to all protective guards (drives, spool guards, etc.)

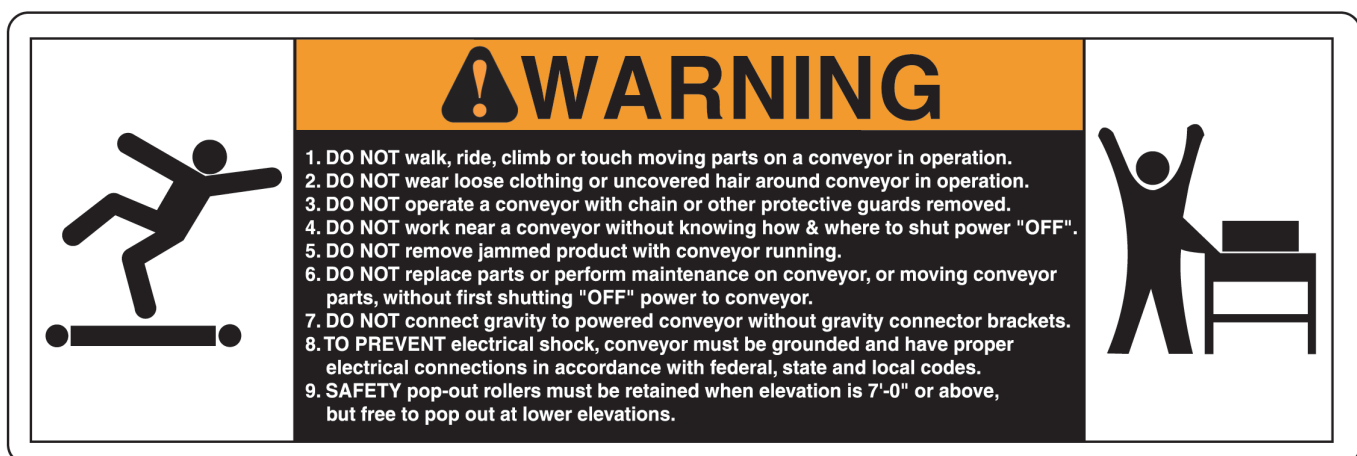

ABOVE: Label placed near all drive assemblies and at 30' intervals

# CAUTIONS, WARNINGS AND HAZARDS INTRODUCTION

This manual was prepared as a “how-to-guide” for installers, end-users and maintenance personnel. It is also intended to educate both owner (purchaser) and all individuals working around the unit, of potential hazards.

With proper installation and maintenance, conveyors are essential for achieving a variety of functions essential in today’s industrial marketplace. By following a simple, periodic maintenance schedule, the life of a typical conveyor (or, most any type of machinery—including our automobiles!) will increase when com-

pared to a similar unit in an application receiving little or no maintenance. You may find that a conveyor can become your best workplace friend by following simple safety guidelines. Failure to follow even the most basic safety suggestions can result in serious personal injury.

Conveyors contain many moving parts—pulleys, belting, chains, sprockets, shafts, rollers, etc. Therefore, it is imperative to become familiar with basic unit operation and know all points of potential hazards.

Remember, when working around or near conveyors (and any industrial machinery)

it is your responsibility to become familiar with the unit, to know potential hazards (many are noted with caution labels) and to operate unit in strict accordance with the safety guidelines in this manual.

Keep this manual in a safe place for future reference. It should be placed where appropriate personnel may maintain proper maintenance and records.

This manual must be read by all new users before operating or working near this unit.

## **WARNING**

**DO NOT OPERATE BEFORE READING THIS MANUAL!  
KEEP IN SAFE PLACE--DO NOT DISCARD!**

# CAUTIONS, WARNINGS AND HAZARDS

## **WARNING**



NEVER connect belt conveyors directly to gravity conveyors, machinery or fixtures without using connector brackets & pop out roller.



ALWAYS anchor permanent supports to floor (or mounting surface). Use 3/8" x 2-1/2" (or longer) wedge anchors for permanent installation in concrete flooring.



It is the responsibility of the customer and installation personnel to supply and install net or mesh guarding on overhead mounted conveyors to prevent product and/or debris from falling to floor in areas where required.



If belt conveyor pulleys are adjusted during installation or maintenance, nip point guard (at drive end on end drive unit) must be readjusted. Nip point guard (take-up end) is automatically adjusted when take-up pulley is adjusted. Nip point guards at both ends of conveyor (center drive) must be readjusted. Center drive guards MUST be replaced after installation or maintenance.



Before unit is ready for operation, snub roller guard (cover) must be adjusted to ensure safe unit operation.



Belt lacing must be kept in good condition for safe work environment.



To check drive sprocket alignment, shut “OFF” and lock out power source before attempting any adjustments.



To check drive sprocket tension, shut “OFF” and lock out power source before any adjustments are attempted.



Electrical controls must be designed by a qualified electrical engineer to ensure that appropriate safety features (emergency stops, pull cords, switches, etc.) are installed on unit for safe operation. Before conveyor start-up, all operators and other personnel coming in contact with unit must be properly trained and must have read accompanying Tech Handbook.



Upon start-up, if belt tracks to one side, turn unit “OFF”, lock out power source and confirm that conveyor is square and that all prime tracking components are square with bed. Belt tracking adjustments should be performed by trained personnel ONLY. Read section on “Belt Tracking” completely before attempting belt tracking adjustments.



Only trained personnel shall perform maintenance functions. Before maintenance operations are performed, shut conveyor “OFF” and lock out power source to prevent unauthorized start-up. When maintenance is completed, only authorized personnel shall be permitted to start conveyor following maintenance or other emergency shut-off.



# ⚠️ WARNING

**WARNING:** All personnel coming in contact with this conveyor should be aware of the following safety guidelines **BEFORE USING OR WORKING AROUND CONVEYOR**. **NOTE:** ALWAYS notify Roach Manufacturing® whenever any conveyor is used in an application or condition other than was originally intended. Failure to notify Roach® may allow conveyor to be operated in a hazardous operating condition. Injuries resulting from negligence or violation of safety instructions hereby removes responsibility of product liability claims from Roach®.

⚠️ Do not operate conveyor with protective guards removed. This includes chain guards, belt guards, snub roller guards, center drive guards and any other safety guard.

⚠️ Do not replace parts or perform maintenance on conveyor, or moving conveyor parts, without first shutting "OFF" power to conveyor and locking out power source.

when conveyors are installed at or below 7'-0" elevation.

⚠️ It is the responsibility of conveyor end-user to comply with all safety standards including OSHA and other federal, state, and local codes or regulations. Install protective guarding and other related safety precautionary equipment to eliminate hazardous operating conditions which may exist when two or more vendors supply machinery for related use.

⚠️ Do not walk, ride, climb, or touch moving parts on a conveyor in operation.

⚠️ Do not connect gravity to powered conveyor without safety gravity connector brackets.

⚠️ Do not wear loose clothing or uncovered hair around conveyor.

⚠️ To prevent electrical shock, conveyor must be grounded, and have proper electrical connections in accordance with federal, state, and local codes.

⚠️ Do not work near conveyor without knowing how & where to shut power "OFF" and lock out power source.

⚠️ Safety pop out rollers in conveyors installed above 7'-0" elevation must be retained by guard rail, clips, etc. Safety pop out rollers must be allowed to pop out

⚠️ Any violation of above safety instructions hereby removes all product liability claims from Roach Manufacturing Corporation®.

⚠️ Do not remove jammed product with conveyor running.

## ABOUT LINE SHAFT CONVEYOR

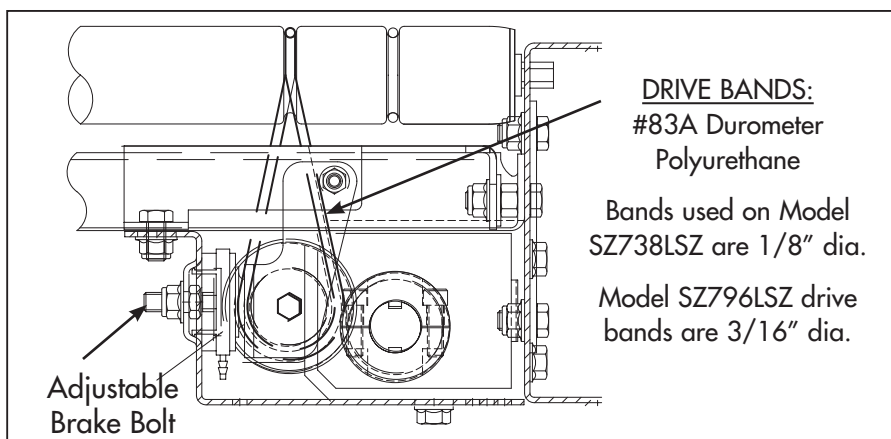

All conveyors will have counterclockwise twist on drive bands standard.

Roach line shaft conveyor, when appropriately applied, is one of the most economical and efficient types of powered conveyor to incorporate into your overall material handling system. Numerous accessories and several intermediate sections may be driven with a single drive which eliminates costs from the actual drives and from motor drive component electrical costs.

Extra drive bands are installed on the unit at the factory on drive shaft between bearing locations allowing future use with minimal installation effort.

### DO NOT USE LINE SHAFT CONVEYORS:

- When rollers must be skewed (for product positioning) greater than 5 degrees.
- If line shaft **MUST** be used, limit skewing to short unit sections and use low friction guard rail.

- When excessive speeds are necessary-15 FPM or less OR faster than 120 FPM.

- In oily or wet conditions which impair the frictional driving forces required.

- In corrosive or abrasive applications.

- When the drive bands are exposed to direct ultraviolet rays.



# RECEIVING AND INSPECTION SHORTAGES, DAMAGES AND RETURN AUTHORIZATIONS

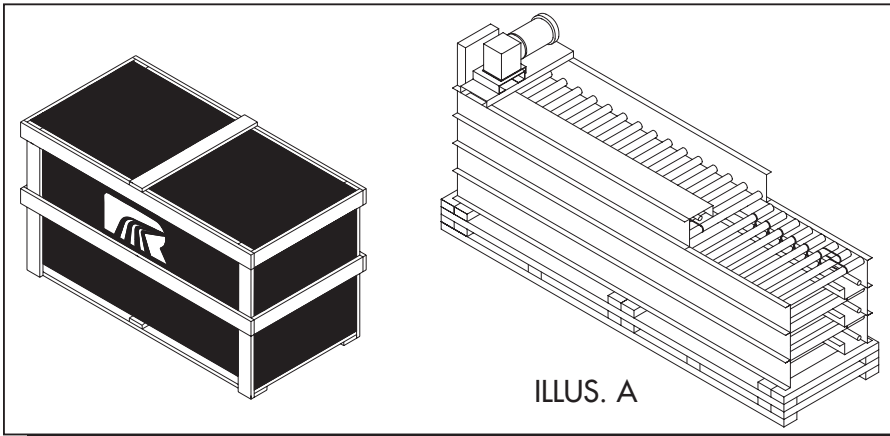

ILLUS. A

NOTE: Do not return goods to factory without prior, written return authorization. Unauthorized returns are subject to refusal at factory.

Before uncrating, check the quantity of items received against bill of lading to confirm that all material has been received. Examine the condition of the equipment to determine if any damage has occurred.

Also, it is possible that some items may become separated from the original shipment. Therefore, when receiving goods,

it is imperative that the bill of lading (or, accompanying freight documentation) be checked to ensure receipt of ALL units ordered including ALL accessories.

Damage and/or shortage in shipment should be reported immediately to both vendor and carrier. Obtain a signed damage report from carrier agent and send copy to vendor. Do not repair any

damage before obtaining this report.

For damaged shipments, consult factory to determine if entire shipment must be returned to factory for repair or if an immediate order should enter production to produce a new, replacement shipment.

In illustration A above, model SZ796LSZ is shown palletized, prepared for shipment.

## UNCRATING

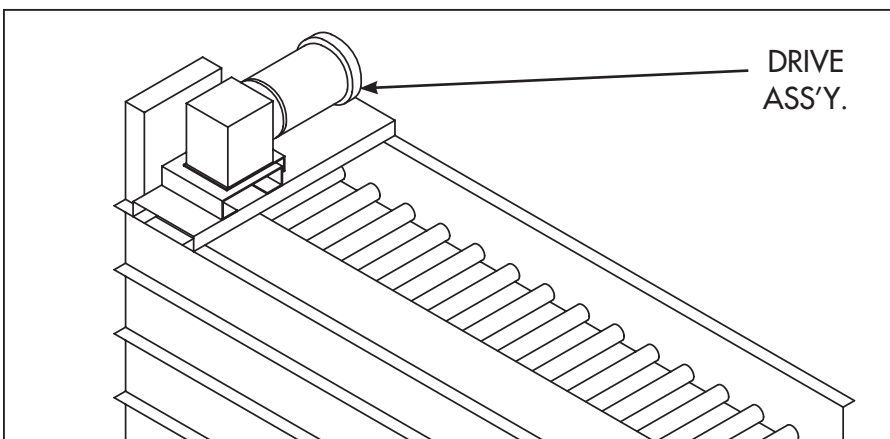

NOTE: Carefully examine shipment during uncrating to ensure that essential components are not discarded. This includes guard rail and other necessary hardware.

After receipt and initial inspection is completed, carefully remove crating and look for essential components and specific accessories that may have been boxed and attached (or 'banded') to crating material. Guard rails and hardware are

often packaged and shipped in this manner. Save all hardware for subsequent use by installation personnel.

The drive section will be shipped mounted to its actual operating bed section (see illustration above).

Some items (electric motors, gearbox, etc.) may be shipped direct from their manufacturer to final destination. Thus, the conveyor may consist of two or more separate shipments.

# GENERAL INSTALLATION INFORMATION

## COUPLING/SHAFT END COVER ALLOCATION

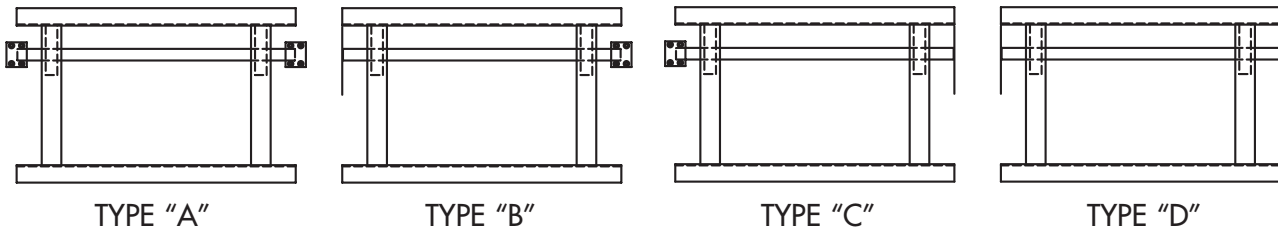

It is only necessary to place a shaft coupling on the end of the drive shaft where it is to connect to another bed section or line shaft unit accessory. Allocation of line shaft Coupling for LSZ conveyors is illustrated in diagram above. Model LSZ ships from the factory in one of four configurations above

and each unit is marked on its corresponding packing list as either type "A", "B", "C" or "D". This marking procedure applies to the end drive shaft coupling only at both ends. Therefore, on units with motor drive, this applies to the coupling arrangement at each end of the overall unit-not at intermedi-

ate bed sections. For units ordered as intermediate bed sections only (without drive), illustration applies to each bed section.

Fully tighten and maintain proper shaft alignment if coupling assembly is added or adjusted in the field.

## PREPARING FOR SETUP

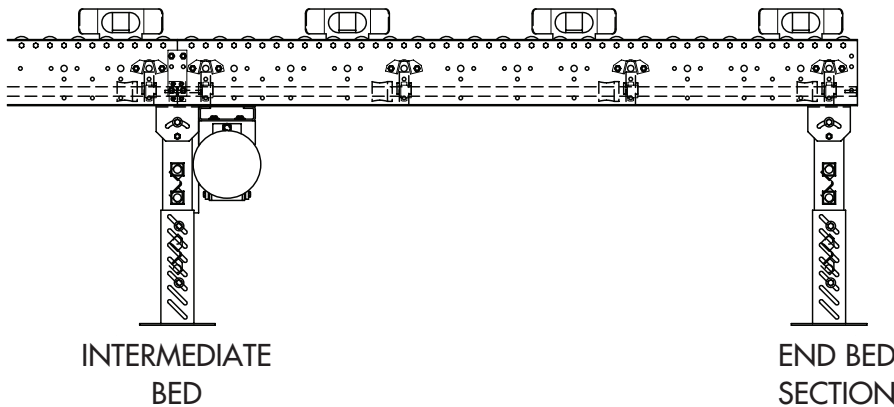

NOTE: When preparing to install conveyor, first locate all component sections in the actual installation area. After uncrating, place bed sections conveying side up.

Conveyors are set up at the factory, unit is test run and receives rigorous quality assurance inspection. At this time unit becomes field-ready.

When preparing to install conveyor, first locate all component sections in the actual installation area. After uncrating, place unit bed sections conveying side up. Refer to bed section drawing (supplied with

shipment and packing list) for location of supports and assemble as shown.

Create a reference base line on floor by marking a chalk line along the centerline of conveyor. Follow base line when installing unit. Conveyor must be level and square or packages will run off to one side. Check level across width of unit. Then confirm that unit is square. A diagonal measurement can determine bed

section squareness. Conveyor must be square and level or packages will run off to one side. Use mechanical hoist (fork truck or other available means) to raise bed sections to approximate installed elevation.

Drive shaft and bed sections are now ready to be attached (and adjusted if necessary) as explained in following section.

# GENERAL INSTALLATION INFORMATION

## ATTACHING BED SECTIONS AND SHAFT COUPLING

The following procedure is recommended when installing intermediate line shaft bed sections.

1. Raise the first bed section to the approximate installed elevation and place floor support under each end as shown on page 6.
2. Move the next adjoining bed into position and place on support.

NOTE: Insert coupling screws from the top.

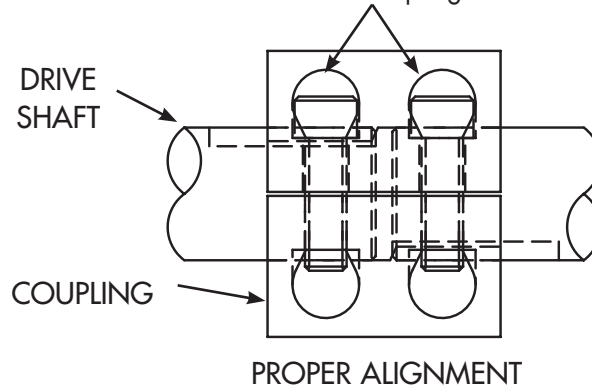

NOTE: Each floor support commonly supports .....2 intermediate beds.

NOTE: Properly seat keys before tightening coupling screws.

3. Next, loosen coupling screws and insert into coupling at end of first bed section.
4. Align coupling assembly and tighten coupling screws.

5. Then attach beds together by connecting splice plates.
6. Securely tighten bolts in splice plates and in floor support top cap assembly.

## OPTIONAL GUARD RAIL

Guard Rail is used to prevent product from falling off conveyor and for maintaining product orientation. Always use when conveyor elevation is above 7 ft. Shown below are Adjustable Channel and Fixed Channel Guard Rail.

Adjustable Channel Guard Rail

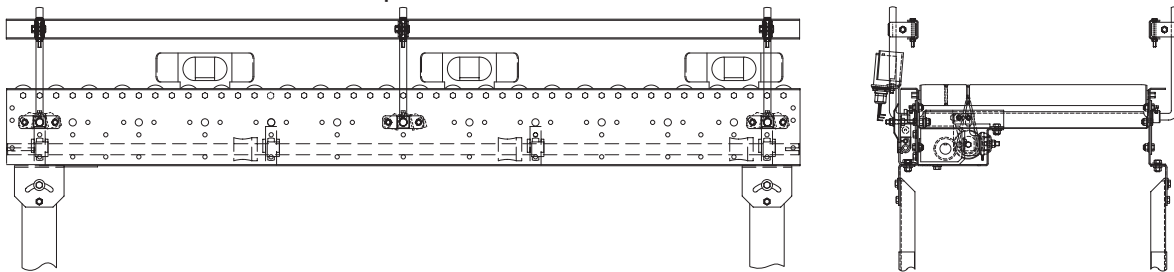

Fixed Channel Guard Rail  
Guard Mounted Above The Photoeye

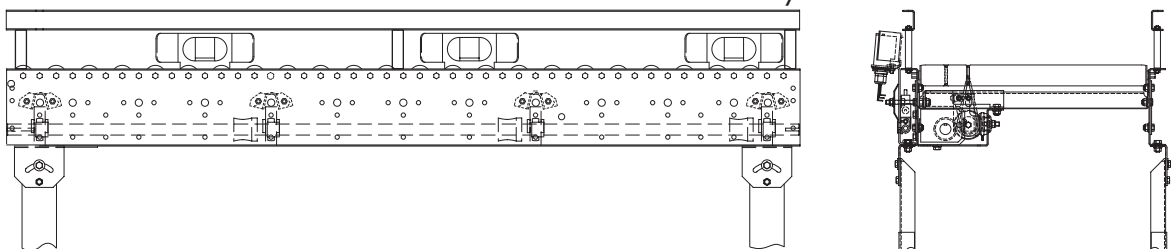



# GENERAL INSTALLATION INFORMATION

## IDENTIFYING/INSTALLING PERMANENT FLOOR SUPPORTS

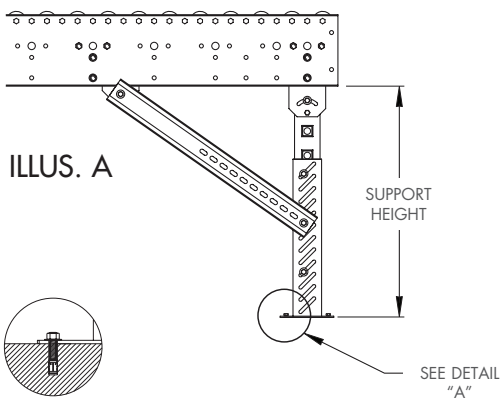

ILLUS. A

Detail "A"

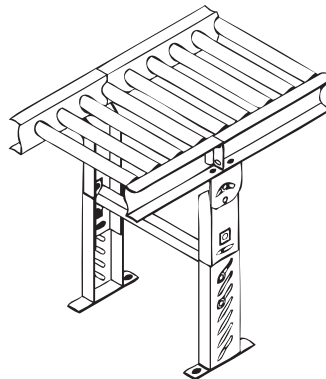

ILLUS. B

**⚠ WARNING**

Always anchor permanent supports to floor (or mounting surface). Use 3/8" x 2-1/2" (or longer) wedge anchors for permanent installation in concrete flooring.

*MINIMUM/MAXIMUM SUPPORT HEIGHT			
SM-1	7-1/4" — 10-1/4"	SM-7	34-1/4" — 46-1/4"
SM-2	10-1/4" — 13-1/4"	SM-8	46-1/4" — 58-1/4"
SM-3	13-1/4" — 16-1/4"	SM-9	58-1/4" — 70-1/4"
SM-4	16-1/4" — 22-1/4"	SM-10	70-1/4" — 82-1/4"
SM-5	20-1/4" — 26-1/4"	SM-11	80-1/4" — 92-1/4"
SM-6	24-1/4" — 36-1/4"	SM-12	92-1/4" — 104-1/4"

Permanent supports may be installed on conveyors at various locations. However, it is most common to use single tier permanent floor supports at each end of a powered section (see illus. A above) and where intermediate bed sections are adjoined (see illus. B above). Notice intermediate supports have two lag bolts in a diagonal pattern while end (terminal) supports have four lag bolts, one in each of the four foot plate mounting holes.

When two (or more) powered conveyors are placed end-to-end, a single tier permanent support may be used at the end junction commonly supporting both units. Check load rating of support before using this method of installation.

Adjust elevation to top of conveyor by loosening bolts in support uprights, raising or lowering conveyor and fully tightening

bolts at desired elevation. Tighten all bolts in supports before unit operation. Complete support installation by lagging support attachment plates to floor. Confirm that unit is level across width of conveyor before completing final support height adj.

\*Supports are normally shipped at minimum support height. See chart above.

## INSTALLATION OF POLYTIER SUPPORTS

MIN. ELEVATION = 11" ELEV.  
(3-1/2" + FRAME)

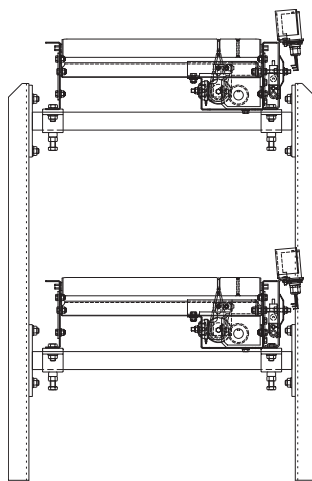

NOTE: To install, raise conveyor to desired elevation, place cross pipe underneath frame, attach cross pipe to upright legs and use U-shaped retainer ("hat") bracket to connect cross pipe to lower conveyor flange.

POLYTIER SUPPORT CHANNEL HEIGHT					
PSM-1	23"	PSM-6	53"	PSM-11	83"
PSM-2	29"	PSM-7	59"	PSM-12	89"
PSM-3	35"	PSM-8	65"	PSM-13	95"
PSM-4	41"	PSM-9	71"	PSM-14	101"
PSM-5	47"	PSM-10	77"	PSM-15	107"

Polytier supports provide convenient installation method for two or more tiers of conveyor. To install, raise conveyor to desired elevation (approximate). Place 1" inside diameter cross pipe underneath lower conveyor flange. Attach cross pipe to upright legs. Use U-shaped retainer

("hat") bracket with coupling plate to connect cross pipe to conveyor flange. Do not tighten fully at this time.

Standard elevation style attachment brackets offer unit elevation of 3-1/2" + frame and includes bracket welded to cross pipe which is bolted to upright legs dur-

ing installation.

When unit is at operating elevation and unit has been checked across width for level, tighten locking bolts in U-shaped bracket. Add knee braces for unit rigidity.

# GENERAL INSTALLATION INFORMATION

## INSTALLING KNEE BRACES AND CASTERS

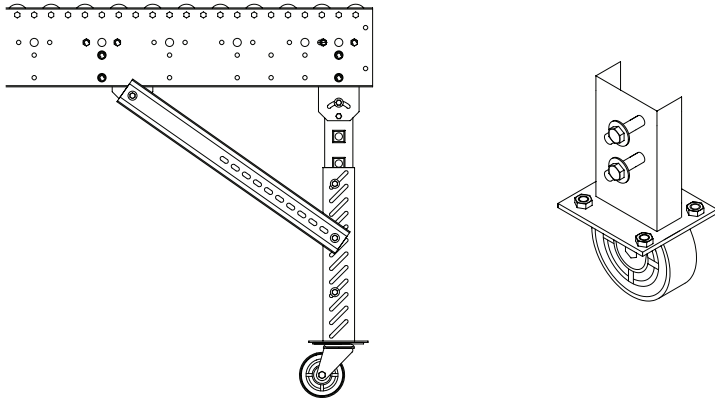

NOTE: Install knee brace (when supplied) after final permanent support installation and elevation adjustment.

Knee braces add strength to permanent supports and stability to units in portable applications. Install knee brace (when supplied) after final permanent support installation and elevation adjustment. Its pivot bracket is bolted to underneath side of lower conveyor flange and slotted end is attached to outer side of support.

Castors (when supplied) are generally installed at the factory. However, when receiving castors direct from their supplier, final attachment to support is necessary. A special slotted pre-punched castor attachment plate is supplied on supports designed for castors.

A standard support is not designed for attachment to castors. Field modification or replacement of outside support assemblies is required.

## INSTALLATION OF CEILING HANGERS

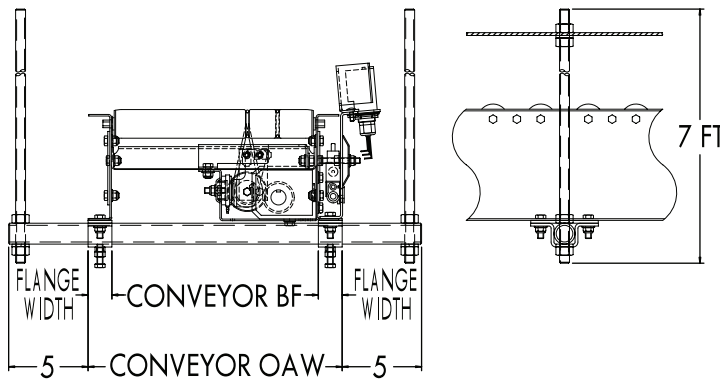

**⚠ WARNING**

It is the responsibility of the customer and installation personnel to supply and install net or mesh guarding on conveyors mounted overhead to prevent product and/or debris from falling to floor in areas where required.

Ceiling hangers are frequently used in high-elevation applications for suspension from ceiling. The 5/8" diameter (#11 UNC) all threaded rod is supplied to allow infinite vertical adjustment along the length of the suspension rod (see illustration above).

Attach and firmly tighten U-shaped retainer ("hat") bracket with coupling

plate to underneath side of frame with hardware provided to hold cross pipe (1" inside diameter) against underneath side of conveyor.

Do not tighten cross pipe locking bolts (these attach in the bottom of the U-shaped retainer bracket) until threaded suspension rods have been firmly secured to ceiling structure.

To adjust conveyor elevation, tighten or loosen lower nut and jam nut on threaded suspension rods to desired elevation. A lock washer must be used on suspension rods to maintain unit at desired elevation.

When unit is at operating elevation and unit has been levelled across bed width, tighten locking bolts in U-shaped bracket to secure position of cross pipe.

# START-UP PROCEDURES

## DRIVE CHAIN AND SPROCKET ALIGNMENT

CHAIN GUARD REMOVED FOR CLARITY

**WARNING: DO NOT OPERATE CONVEYOR WITH CHAIN GUARD REMOVED**

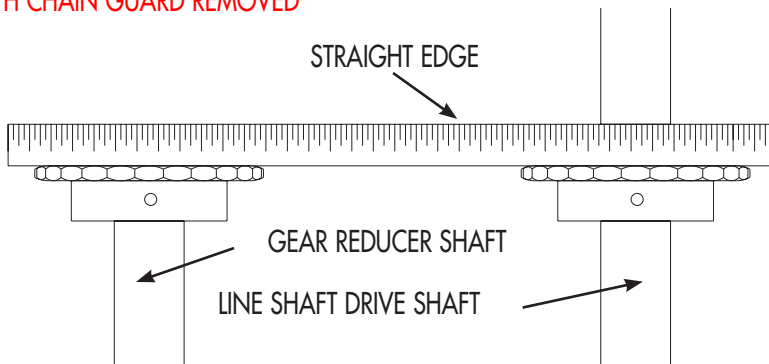

Set up and maintenance of drive sprocket and drive chain alignment is critical. A periodic visual inspection is recommended to confirm alignment of drive components (which includes both drive sprockets and drive chain). Should set screws become loose, drive sprockets are subject to excessive wear and ultimately, to untimely replacement.

To check drive sprocket alignment, it is imperative that conveyor is shut "OFF" and power source is locked out before any adjustments are attempted. Remove chain guard cover and place straight-edge (see illustration above) across face of both drive sprockets. If re-alignment is necessary, loosen set screws and adjust drive sprockets as required. Remember to

**WARNING**

To check drive sprocket alignment, it is imperative that conveyor is shut "OFF" and power source is locked any out before any adjustments are attempted.

securely tighten set screws when alignment is complete.

Before replacing chain guard cover, check drive chain tension as described in following section, "Drive Chain and Sprocket Tension."

## DRIVE CHAIN AND SPROCKET TENSION

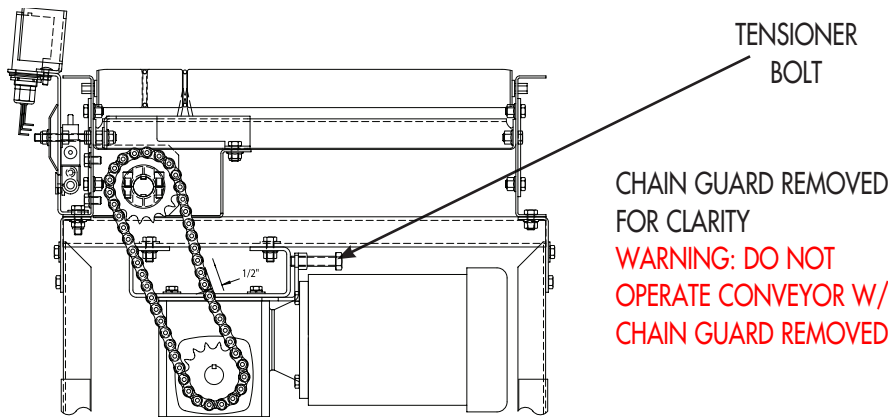

Maintaining proper chain tension is especially important. Again, a periodic visual inspection is recommended to ensure chain tension within a pre-determined operating range.

Remember, before any adjustments are attempted, conveyor must be shut "OFF" and power source locked out.

Before replacing chain guard cover,

**WARNING**

To check drive sprocket tension, shut "OFF" and lock out power source before any adjustments are attempted.

To adjust drive chain tension:

- Step 1 - Loosen the (4) bolts that hold the gear reducer to the motor baseplate
- Step 2 - Tension bolt located on reducer push plate should be tightened (rotate clockwise) if chain is too loose and loosen (rotate counter clockwise) if chain is too tight. Tighten until proper operation range is achieved.
- Step - 3 Tighten the (4) bolts that hold the gear reducer to the motor base plate.
- Step - 4 Replace all guards that were removed.

**WARNING:** Do not operate unit until chain guard cover is replaced. Serious operator or other personal injury could result if protective guarding is not replaced.



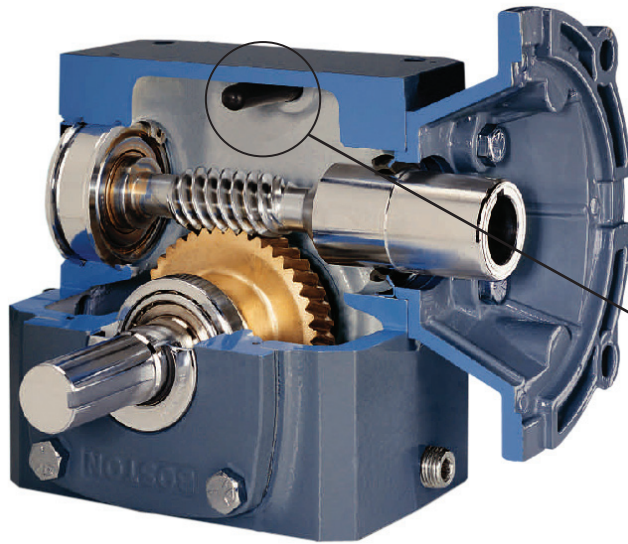

## NOTE

The gear reducer is supplied with a "PosiVent<sup>®</sup>". No vent plugs are required.

PosiVent Unique design incorporates a single seam construction. Factory filled with synthetic lubrication for universal mounting. Lubed for life, no oil changes are required.

To expedite the installation and start-up process, all gear reducers are shipped filled with oil. The reducers are sealed and lubed for life and require no oil changes.

## PREPARING FOR INITIAL START-UP



## **⚠ DANGER**

**WARN ALL PERSONNEL TO KEEP CLEAR OF CONVEYOR DURING UNIT START-UP**

Electrical controls must be designed by a qualified electrical engineer to ensure that appropriate safety features (emergency stops, pull cords, switches, etc.) are installed on unit for safe operation. Before conveyor start-up, all operators and other personnel coming in contact with unit must be properly trained and must have read accompanying Tech Handbook.

Before conveyor start-up, all operators and other personnel coming in contact with unit must be properly trained and must have read accompanying Tech Handbook.

Provisions must be in order to instruct all personnel coming in contact with conveyor on the location of emergency stops, pull cords, etc.

A routine maintenance program should be implemented before unit is placed into operation so that fundamental unit components are attended to. This maintenance program should include an inspection to ensure that any dangerous or hazardous operating conditions are noted and IMMEDIATELY corrected, as well as including electrical and mechanical unit inspections and corrections.

Finally, when conveyor is initially started, an immediate visual inspection should include motor, gear reducer, belt tracking (discussed in following section under "Belt Tracking") and related adjustments noted in handbook for unit/component corrections.

## **WARNING**

Only trained personnel shall perform maintenance functions. Before maintenance operations are performed, conveyor must be shut "OFF" and disconnects locked in the "OFF" position to prevent unit from unauthorized start-up.

One of the most important guidelines for maximizing conveyor operation and personnel safety is to implement a regular maintenance schedule and train personnel on the appropriate needs of the specific unit.

Only trained personnel shall perform maintenance functions. Before maintenance operations are performed, conveyor must be shut "OFF" and disconnects locked in the "OFF" position to prevent unit from unauthorized start-up during maintenance. All personnel should be informed of the safety procedures associated with unit maintenance and performance.

Do not perform any work on conveyors or conveyor system while in operation unless it is impossible to otherwise conduct adjustment, lubrication or other maintenance function. Only experienced, trained personnel possessing advanced hazards-training should attempt such critical operations.

## MAINTENANCE AND FOLLOW-UP DETAILS

### **WARNING**

Only trained personnel shall perform maintenance functions. When maintenance is completed, only authorized personnel shall be permitted to start conveyor following maintenance or other emergency shut-off.

While performing maintenance do not wear loose clothing. Immediately report any hazardous conditions—sharp edges, pinch (or nip) points or other conditions that may result when several manufacturers supply machinery which may create operating hazards.

When using mechanical aids such as hoists, cables, or cranes exercise extreme caution to prevent damage to conveyors or other integrated machinery which may create a working hazard when maintenance is completed and units are in operation.

Clean up any spilled lubricants or other materials used in the maintenance process or those which may be deposited during unit operation. Eliminating poor housekeeping practices increases unit efficiency while creating safer personnel working conditions.

After maintenance, conduct visual inspection to ensure that all safety devices and guards have been replaced. Confirm that all units are clear of tools, debris or other items. Before starting conveyor, check condition of unit caution labels (see "CAUTION LABELS" at front of handbook). If labels have been destroyed or are not clearly legible, call 870.483.7631 to receive replacement labels. Placement of caution labels is critical to avoid unauthorized unit operation which may result in hazardous working conditions for all related personnel coming in contact with conveyor.

Warn personnel that conveyor is being prepared for start-up and to stay clear of unit. Do not start conveyor until all personnel are clear. When maintenance is completed, only authorized personnel shall be permitted to start conveyor following maintenance or other emergency shut-off.

# MAINTENANCE AND LUBRICATION PERIODIC MAINTENANCE SCHEDULE

MODEL NO. \_\_\_\_\_

WEEKLY RECOMMENDED MAINTENANCE SCHEDULE*	
COMPONENT	DETAIL OF MAINTENANCE
Belting	Lubricate in dirty, dusty or moist/wet conditions.
Unit Safety Check	Confirm placement of all guards, warning labels & check for loose bolts, nip points & other hazards.

WEEKLY RECOMMENDED MAINTENANCE SCHEDULE*	
COMPONENT	DETAIL OF MAINTENANCE
Gear Reducer	Check for leaks.
Pillow Block/Flange Bearings	Lubricate (normal conditions)
Drive Chain	Check for proper operating tension & for overall wear & lubricate.
Drive Sprockets	Check for overall wear & re-tighten set screws.

WEEKLY RECOMMENDED MAINTENANCE SCHEDULE*	
COMPONENT	DETAIL OF MAINTENANCE
Gear Reducer	Check for leaks.
Drive Chain	Clean (brush in solvent) & re-lubricate by applying lubricant to inside of chain with brush or spout can at 2000 hour intervals.
Motor	Check & clean motor ventilation openings at 500 hour intervals. Check misc. operating conditions (normal heat & noise)

\*All charts are for guidelines in normal operating or 'as noted' conditions. Severe applications may warrant additional maintenance.





# TROUBLE SHOOTING AND REPLACEMENT PARTS

## TROUBLE SHOOTING / SERIAL PLATE

TROUBLE SHOOTING		
TROUBLE	PROBABLE CAUSE	REMEDY
Motor & gear reducer running excessively hot, repeated stalling or hard to start	A. Frozen sprocket B. Overload C. Electrical	A. Check and inspect all sprockets and bearings. Replace sprockets failing to rotate or that are difficult to rotate. B. Reduce cause and/or increase motor horsepower. C. check wiring and circuits, take ampere reading, replace motor if necessary.
Motor & gear reducer makes excessive noise	A. Damaged gears B. Faulty bearing	A. Replace unit. B. Replace bearing.
Drive chain, conveying chain or sprockets experience excessive wear	A. Excessive chain tension B. Sprockets misaligned C. Chain not lubricated D. Damaged sprocket or chain E. Misalignment of chain guard F. Dirty chain	A. Reduce chain tension. B. Realign with straight edge across sprocket faces. C. Lubricate chain with approved lubricant, wipe away excess lubricant. D. Replace damaged component. E. Adjust chain guard assembly as necessary. F. Clean thoroughly and lubricate with approved lubricant.
Drive chain, conveying chain or sprockets make excessive noise	A. Insufficient chain tension B. Chain not adequately lubricated C. Sprockets misaligned	A. Adjust chain tension. B. Lubricate chain with approved lubricant, wipe away excess lubricant. C. Realign sprockets with straight edge across sprocket faces.
Pulsating chain	A. Insufficient chain tension B. Misalignment of chain guard C. Overload	A. Adjust chain tension. B. Adjust chain guard assembly as necessary. C. Inspect for obstruction to or drag on conveyor.
Broken chain	A. Frozen bearing or sprocket shaft B. Worn or damaged chain C. Obstructed or jam	A. Inspect for damaged bearings, replace if necessary. Replace links as required. B. Replace chain as required. C. Remove obstruction to clear jam.
Tread roller(s) stalls or does not turn when loaded	A. Product overload B. Drive band broken C. Oily conditions D. frozen roller bearing	A. Alter product loading to specified load rating. Consult factory. B. Replace drive band. C. Remove oil with recommended cleaner. D. Replace roller.
Sprocket loose on shaft	A. Loose set screws B. Worn or damaged key	A. Realign sprockets with straight edge and tighten set screws. B. Replace with new key.
Excessive slack in chain	A. Normal wear	A. Expect rapid chain growth in first two weeks of operation. Adjust chain tension.

## ORDERING REPLACEMENT PARTS



**ROACH CONVEYORS**  
808 HIGHWAY 463  
TRUMANN, AR 72472  
TEL. 870-483-7631

SERIAL NO.      123456

To order any replacement parts or when calling for assistance with any powered conveyor, ALWAYS provide the unit serial number. Shown at actual size, this is placed on the conveyor frame near the location of the drive assembly.

To order replacement parts or add-on components, contact the Roach distributor who originally furnished the unit if possible. If this is not possible, contact the National Sales Office at 870-483-7631 for the name of the authorized Roach

distributor in your area. Have unit model number and serial number BEFORE calling. Refer to unit drawings (in rear section of hand-book) for part numbers if ordering replacement parts.

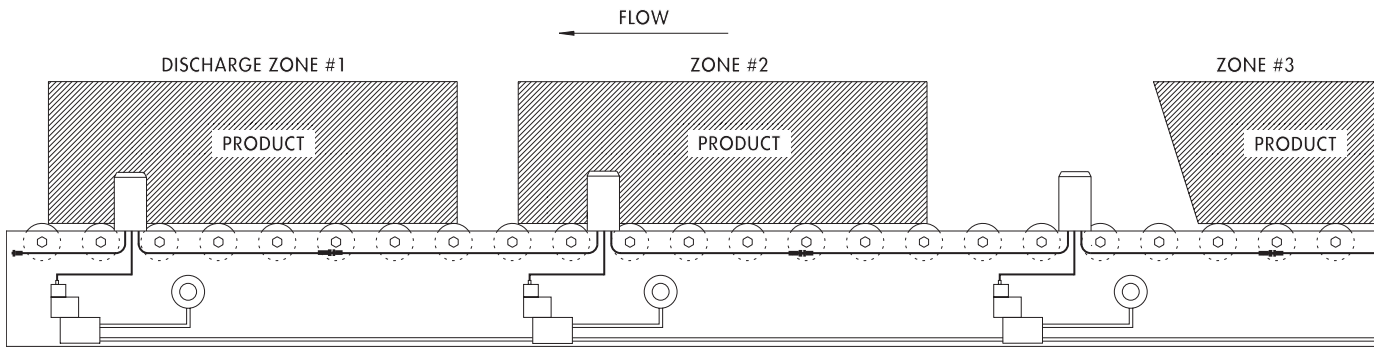

Roach Smart Zone® model SZ796LSZ is a zero pressure accumulation conveyor utilizing photo sensors rather than mechanical sensor rollers to detect presence of product. Each zone requires one photo sensor, reflector, solenoid valve and one pneumatic cylinder per zone. Also, a 24 volt DC power supply with 115/1 input voltage is required per

conveyor, which is capable of powering up to 50 zones. The power supply delivers a low voltage signal to each "daisy-chained" photo sensor located in each accumulating zone.

Since Smart Zone® does not require physical package or carton weight to depress mechanical sensor, minimal weight objects can be accumulated.

Here's how Smart Zone® accumulates. The first package on the conveyor travels until it blocks the photo sensor in discharge zone #1. The next package accumulates in zone #2 when it blocks the photo sensor in zone #2. The next package accumulates in zone #3 and so forth. This process is repeated for all successive zones.

## SMART ZONE® DETAILS

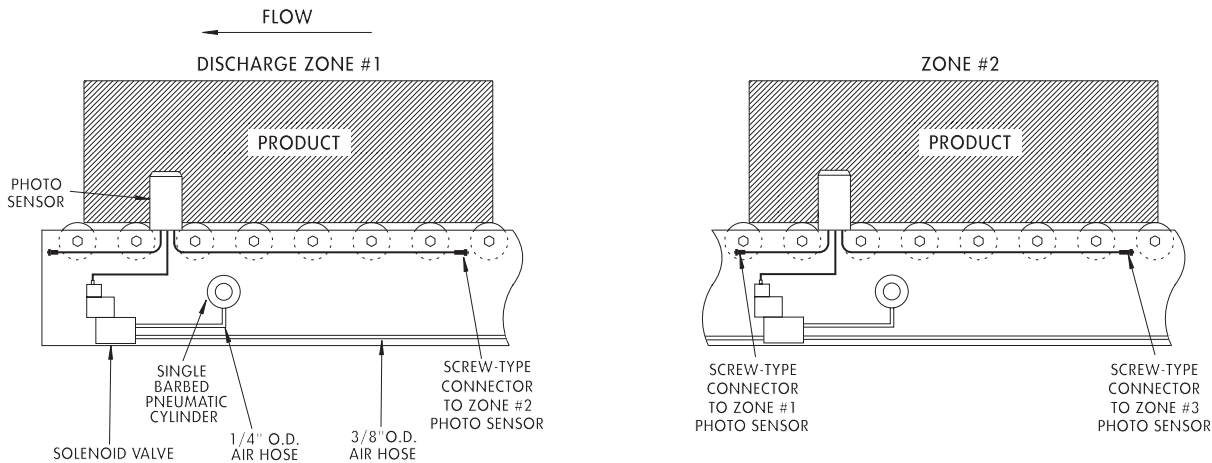

Photo sensors, reflectors, solenoid valves and pneumatic cylinders are shipped mounted, connected and tested on Smart Zone®. When mating individual Smart Zone® bed sections during field installation, two simple connections are required, neither requiring any tools. First, photo sensors must be adjoined across bed sections by screw-type connection. The

second connection involves 3/8" O.D. hose and solenoid valve. The hose is pushed in 3/8" quick connect push-in hose fitting on the solenoid valve.

When a product blocks discharge zone #1 photo sensor, a signal is delivered to the pneumatic cylinder in this zone which shifts the zone into accumulation mode. The

second product will stop moving when it blocks the photo sensor in zone #2 and so forth. A product cannot accumulate in a zone until a product is accumulated in the adjacent downstream zone.



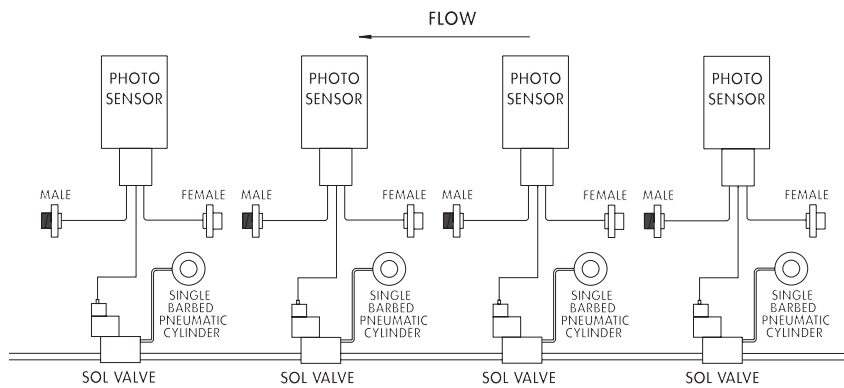

**WARNING:** Electrical controls must include appropriate safety features (emergency stops, pull cords, switches, etc.) installed on unit for safe operation. Before conveyor start-up, all operators and other personnel coming in contact with unit must be properly trained and must have read accompanying Tech Handbook.

The standard mode of operation for Roach Smart Zone® is zone singulation operation. The standard mode of product release for Smart Zone® is therefore, zone singulation release. Each product is accumulated in a separate zone on the conveyor. A product advances into the adjacent downstream zone when that

zone is clear. The photo sensor clears and a single product advances.

To offload utilizing standard zone singulation operation, operator uses a relay contact to the conveyor power supply to discharge a single product.

Finally, an operator may offload Smart

Zone® by simply manually removing a product from the discharge zone, which allows another product to advance into the discharge zone when the previous product clears that zone.

**NOTE:** Maximum air line pressure must not exceed 30PSI.

## SMART ZONE® SLUG & SINGULATION RELEASE / SLUG LOADING

Another common feature for Smart Zone® conveyors is slug release. When utilizing slug release, all zones are powered at once to release all accumulated products. If the slug mode is selected from Smart Zone® power supply (via customer-supplied relay contact) the conveyor remains in slug mode for both slug releasing and slug loading.

These products will continue in motion until either an additional sensor (not supplied with Smart Zone®) stops the Smart Zone® from continuously running or a customer-supplied relay contact switches power supply from slug mode.

ADDITIONAL PHOTOEYE CONNECTIONS WHEN POWER SUPPLY IS LOCATED IN CENTER OF CONVEYOR

PHOTOEYE CONNECTION WITH POWER SUPPLY AT DISCHARGE OF CONVEYOR

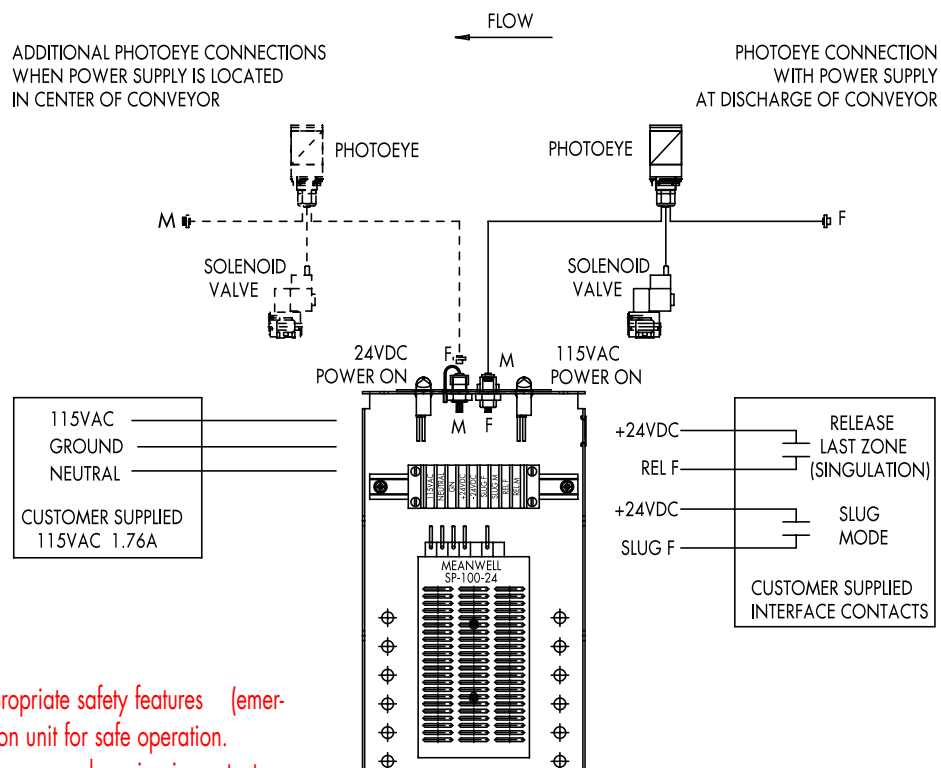

**WARNING:** Electrical controls must include appropriate safety features (emergency stops, pull cords, switches, etc.) installed on unit for safe operation. Before conveyor start-up, all operators and other personnel coming in contact with unit must be properly trained and must have read accompanying Tech Handbook.

# PARTS LIST FOR LINE SHAFT CONVEYORS

## SZ738LSZ BED SECTION 1.5" ROLLER CENTERS

ITEM #	DESCRIPTION	ITEM #	DESCRIPTION
1	Drive Collar (S12798)		30" Zone Roller BF 24-3/8" 36" Zone Roller BF 30-3/8"
2	Roller Stationary Bracket		
3	1/4"-20 X 1/2"LG Whiz Lock Screw	38	156G Zone Drive Roller Assy (Mid Only) (156G-BF-A-ZDR) Located. Between End Rollers Per Bed Section 18" Zone Roller BF 15-3/8" 24" Zone Roller BF 21-3/8" 30" Zone Roller BF 27-3/8" 36" Zone Roller BF 33-3/8"
4	1/4" Steel Spring Nut		
5	Roller Actuator Bracket LH		
6	5/16" X 1/4" X 1/4" -20 SHSS		
7	5/16" 18-8 S.S. Flat Washer		
8	1/4"-20 Flange Nut		
9	Brake Pad Bolt (3/8"-16 X 1-1/2"LG)		
10	3/8" Hex Jam Nut		
11	3/8" Nylon Insert Smooth Flange Nut	40	SZ796LSZ Frame Crossbrace
12	Lineshaft Splice Plate	41	Side Channel (24"-120")
13	Main-line Drive Shaft (24"-120")		
14	Coupling Assembly (A38222)		
15	1/4"SQ X 7/8" LG Keystock	42	Smartzone® Plumbing Kit Smartzone® Photo Eye Smartzone® Valve
16	Reducer Spacer Channel		
17	Drive Bed End Section Guard		
18	1/4"-20 X 1/2"LG Whiz Lock Screw		
19	1/4"-20 Flange Nut		
20	Pivot Mount		
21	3/8" X 1-1/4"LG HHCS		
22	3/8" Hex Nut		
23	3/8" Flat Washers		
24	3/8" Nylon Insert Smooth Flange Nut		
25	Smartzone® Mounting Bracket	44	738 Lineshaft Zone accumulator Drive Kit Reducer Space Plate Chain Guard Top Cover L.H. Chain Guard Filler L.H. Chain guard Cover Reducer Push Plate Motorbase Plate Motorbase Stiffener Assembly
26	3/8" X 3"LG HHTB		
27	3/8" Flat Washers		
28	3/8" Hex Nut		
29	3/8" X 3/4"LG HHCS		
30	3/8" Nylon Insert Smooth Flange Nut		
31	Smartzone® Guard		
32	1/4"-20 X 3/4"LG Carriage Bolt		
33	1/4"-20 Flange Nut		
34	138 Grooved Roller Assembly @4.5 (138G-BF-F-G1C)		
35	138 Double Grooved Rollers Assembly @2.5, 4.5 (138G-BF-F-G2C)	46	Lineshaft Pillow Block Bearing (BRW04125)
36	156G Zone Drive Roller Assy. (Single Only) (156G-BF-A-ZDR) 24" Zone Roller BF 15-3/8" 30" Zone Roller BF 21-3/8" 36" Zone Roller BF 27-3/8"	47	3/8"-16 X 1/2" Hex Washer Head Flange Bolt
37	156G Zone Drive Roller Assy. (Ends Only) (156G-BF-A-ZDR) Located at Each End Only Per Bed Section 18" Zone Roller BF 12-3/8" 24" Zone Roller BF 18-3/8"	48	3/8" X 3/4" LG. HHCS
		49	3/8" Nylon Insert Smooth Flange Nut
		50	3/8" Flat Washers
		51	Spool Spacer (MCW06432)
		52	1/8" Dia. X 12-3/4" LG. Clear Drive Belt (VBW71382)
		53	1/8" Dia. X 5-1/4" LG. Clear Slave Belt (VBW71378)
		54	Smartzone® Reflector Mount Bracket
		55	3/8" Flat Washers
		56	3/8" x 3/4"LG. HHCS
		57	3/8" Nylon Insert Smooth Flange Nut
		58	Cable Hold Down Bracket
		59	Lineshaft End Kit Assembly End Cover Guard 1/4" x 1/2" Whiz Lock Screw 1/4" Steel Spring Nut

Specify Unit Serial Number when ordering replacement parts to ensure proper allocation of components (See Ordering Replacement Parts on page 12).

Recommended Spare Parts are shown in red. Charted are item no. and part description

When ordering use example below.

Example: Need a replacement drive collar (S12798) for a SZ738LSZ Bed Section with 1.5" Roller Centers.

Part No: SN 123456 - 1 - Drive Collar

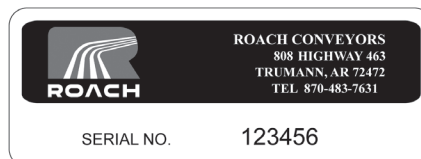

# PARTS LIST FOR LINE SHAFT CONVEYORS SZ738LSZ BED SECTION 1.5" ROLLER CENTERS

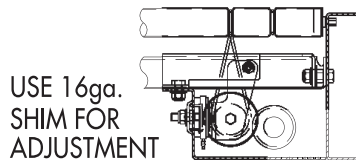
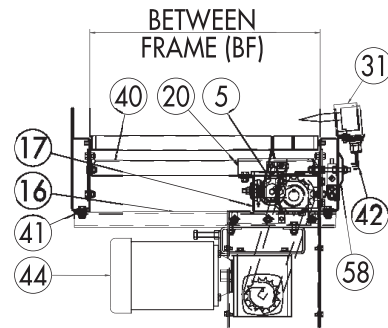
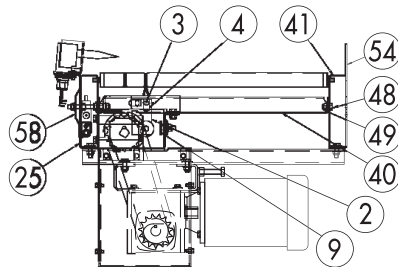
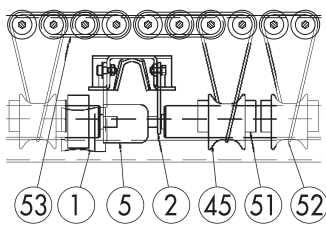
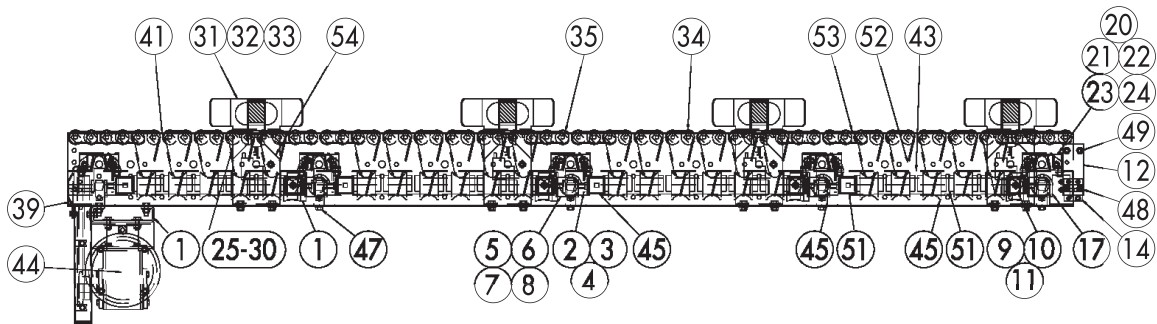
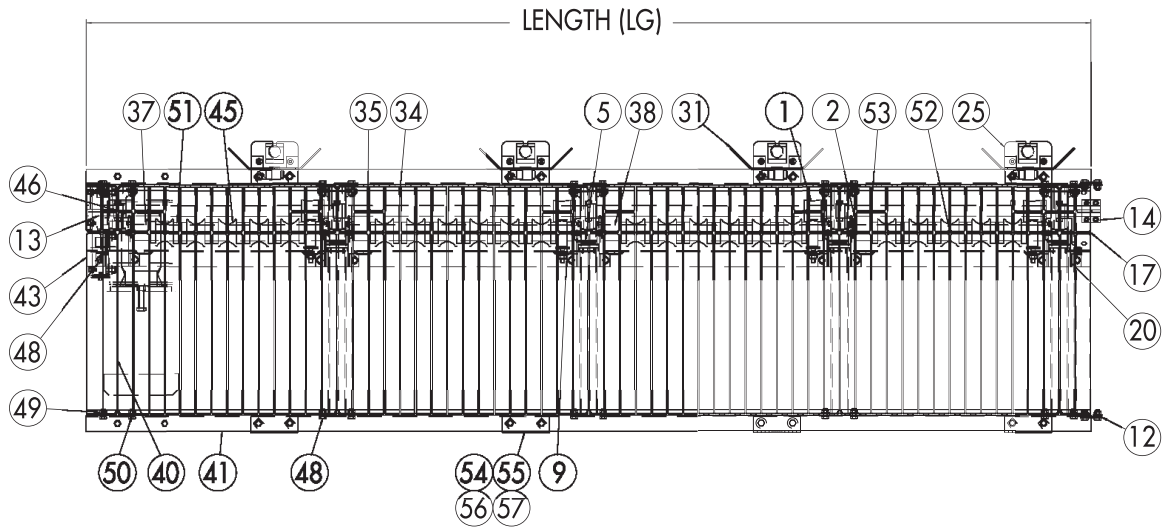

BOTTOM GUARD IS TO BE ADJUSTED IN SO BRAKE BOLT IS 1/16" FROM DRIVE WHEEL WHEN ZONE ROLLER IS ENGAGED OR TOUCHING DRIVE COLLAR.

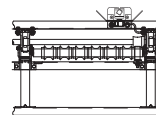

END KIT ASSEMBLY

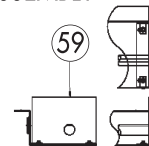

SZ738LSZ will have counterclockwise twist on drive bands standard.

# PARTS LIST FOR LINE SHAFT CONVEYORS

## SZ738LSZ BED SECTION 3" ROLLER CENTERS

ITEM #	DESCRIPTION	ITEM #	DESCRIPTION
1	Drive Collar (S12798)	38	156G Zone Drive Roller Assy (Ends Only) (156G-BF-A-ZDR) Located At Each End Only Per Bed Section 18" Zone Roller BF 12-3/8" 24" Zone Roller BF 18-3/8" 30" Zone Roller BF 24-3/8" 36" Zone Roller BF 33-3/8"
2	Roller Stationary Bracket		
3	1/4"-20 X 1/2"LG Whiz Lock Screw		
4	1/4" Steel Spring Nut		
5	Roller Actuator Bracket LH		
6	5/16" X 1/4" X 1/4" -20 SHSS		
7	5/16" 18-8 S.S. Flat Washer	39	156 G Zone Drive Roller Assembly (Mid Only) (156G-BF-A-ZDR) Located Between End Rollers Per Bed Section 18" Zone Roller BF 15-3/8" 24" Zone Roller BF 21-3/8" 30" Zone Roller BF 27-3/8" 36" Zone Roller BF 33-3/8"
8	1/4"-20 Flange Nut		
9	Brake Pad Bolt (3/8"-16 X 1-1/2"LG)		
10	3/8" Hex Jam Nut		
11	3/8" Nylon Insert Smooth Flange Nut		
12	Lineshaft Splice Plate		
13	Main-line Drive Shaft (24"-120")	40	Drive Shaft End Cover
14	Coupling Assembly (A38222)	41	SZ796LSZ Frame Crossbrace
15	1/4"SQ X 7/8" LG Keystock	42	Side Channel (24"-120")
16	Reducer Spacer Channel	43	Smartzone® Plumbing Kit Smartzone® Photo Eye Smartzone® Valve
17	Drive Bed End Section Guard		
18	1/4"-20 X 1/2"LG Whiz Lock Screw		
19	1/4"-20 Flange Nut	44	Drive Bed Guard (24"-120")
20	Pivot Mount	45	738 Lineshaft Zone Accumulator Drive Kit Reducer Space Plate Chain Guard Top Cover L.H. Chain Guard Filler L.H. Chain guard Cover Reducer Push Plate Motorbase Plate Motorbase Stiffener Assembly
21	3/8" X 1-1/4"LG HHCS		
22	3/8" Hex Nut		
23	3/8" Flat Washers		
24	3/8" Nylon Insert Smooth Flange Nut		
25	Smartzone® Mounting Bracket		
26	3/8" X 3"LG HHTB		
27	3/8" Flat Washers		
28	3/8" Hex Nut	46	Lineshaft Spool (BRW04608)
29	3/8" X 3/4"LG HHCS	47	Lineshaft Pillow Block Bearing (BRW04125)
30	3/8" Nylon Insert Smooth Flange Nut	48	3/8"-16 X 1/2" Hex Washer Head Flange Bolt
31	Smartzone® Guard	49	3/8" X 3/4" LG. HHCS
32	1/4"-20 X 3/4"LG Carriage Bolt	50	3/8" Nylon Insert Smooth Flange Nut
33	1/4"-20 Flange Nut	51	3/8" Flat Washers
34	138 Grooved Roller Assembly @4.5 (138G-BF-F-G1C)	52	Spool Spacer (MCW06432)
35	138 Double Grooved Rollers Assembly @2.5, 4.5 (138G-BF-F-G2C)	53	1/8" Dia. X 12-3/4" LG. Clear Drive Belt (VBW71382)
36	138 Grooved Roller Assembly @2.5 (138G-BF-F-G1A)	54	1/8" Dia. X 8-1/4" LG. Clear Slave Belt (VBW71379)
37	156G Zone Drive Roller Assy. (Single Only) (156G-BF-A-ZDR) 24" Zone Roller BF 15-3/8" 30" Zone Roller BF 21-3/8" 36" Zone Roller BF 27-3/8"	55	Cable Hold Down Bracket
		56	Lineshaft End Kit Assembly End Cover Guard 1/4" x 1/2" Whiz Lock Screw 1/4" Steel Spring Nut

Specify Unit Serial Number when ordering replacement parts to ensure proper allocation of components (See Ordering Replacement Parts on page 12).

Recommended Spare Parts are shown in red. Charted are item no. and part description

When ordering use example below.

Example: Need a replacement drive collar (S12798) for a SZ738LSZ Bed Section with 3" Roller Centers.

Part No: SN 123456 - 1 - Drive Collar





# PARTS LIST FOR LINE SHAFT CONVEYORS SZ738LSZ BED SECTION 3" ROLLER CENTERS

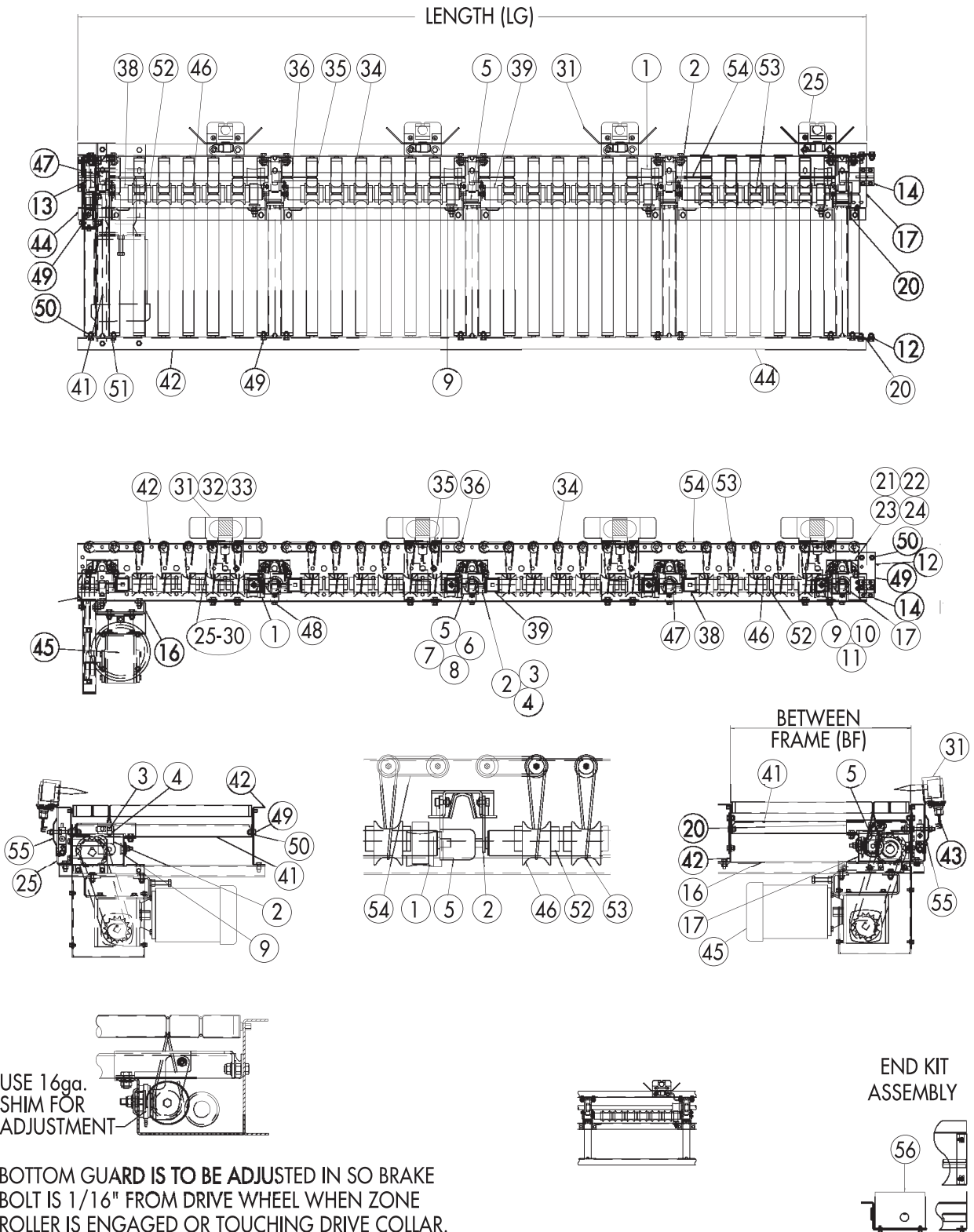

SZ738LSZ will have counterclockwise twist on drive bands standard.

# PARTS LIST FOR LINE SHAFT CONVEYORS INTERMEDIATE SZ738LSZI BED SECTION 1.5" ROLLER CENTERS

ITEM #	DESCRIPTION	ITEM #	DESCRIPTION
1	Drive Collar (S12798)	32	156G Zone Drive Roller Assembly (Ends Only) (156G-BF-A-ZDR) Located At Each End Only Per Bed Section 18" Zone Roller BF 12-3/8" 24" Zone Roller BF 18-3/8" 30" Zone Roller BF 24-3/8" 36" zone Roller BF 30-3/8"
2	Roller Stationary Bracket		
3	1/4"-20 X 1-2"LG Whiz Lock Screw		
4	1/4" Steel Spring Nut		
5	Roller Actuator Bracket LH		
6	5/16" X 1/4" X 1/4"-20 SHSS		
7	5/16" 18-8 S.S. Flat Washer		
8	1/4"-20 Flange Nut	33	156G Zone Drive Roller Assembly (Mid Only) (156G-BF-A-ZDR) Located Between End Rollers per Bed Section 18" Zone Roller BF 15-3/8" 24" Zone Roller BF 21-3/8" 30" Zone Roller BF 33-3/8" 36" Zone Roller BF 33-3/8"
9	Brake Pad Bolt (3/8"-16 X 1-1/2"LG)		
10	3/8" Hex Jam Nut		
11	3/8" Nylon Inset Smooth Flange Nut		
12	Lineshaft Splice Plate		
13	Mainline Drive Shaft (24"-120")	34	SZ796LSZ Frame Cross Brace
14	Coupling Assembly (A38222)	35	Side Channel (24"-120")
15	Pivot Mount	36	Smartzone® Plumbing Kit Smartzone® Photo Eye Smartzone® Valve
16	3/8" X 1-1/4"LG. HHCS		
17	3/8" Hex Nut		
18	3/8" Flat Washers	37	Intermediate Bed Guard (24"-120")
19	3/8" Nylon Inset Smooth Flange Nut	38	Lineshaft Spool (BRW04608)
20	Smartzone® Mounting Bracket	39	Lineshaft Pillow Block Bearing (BRW04125)
21	3/8" X 3"LG. HHTB	40	3/8"-16 X 1/2" Hex Washer Head flange Bolt
22	3/8" Flat Washers	41	3/8" X 3/4"LG. HHCS
23	3/8" Hex Nut	42	3/8" Nylon Inset Smooth Flange Nut
24	3/8" X 3/4"LG. HHCS	43	3/8" Flat Washers
25	3/8" Nylon Inset Smooth Flange Nut	44	Spool Spacer (MCW06432)
26	Smartzone® Guard	45	1/8" Dia. X 12-3/4"LG. Clear Drive Belt (VBW71382)
27	1/4"-20 X 3/4"LG Carriage Bolt	46	1/8" Dia. X 8-1/4"LG. Clear Slavebelt (VBW71379)
28	1/4"-20 Flange Nut	47	Smartzone® Reflector Mount Bracket
29	138 Grooved Roller Assembly @4.5 (138G-BF-F-G1C)	48	3/8" Flat Washers
30	138 Double Grooved Roller Assembly @ 2.5 , 4 (138G-BF-F-G2C)	49	3/8" x 3/4"LG. HHCS
31	156G Zone Drive Roller Assembly (Single Only) (156G-BF-A-ZDR) 24" Zone Roller BF 15-3/8" 30" Zone Roller BF 21-3/8" 36" Zone Roller BF 27-3/8"	50	3/8" Nylon Inset Smooth Flange Nut
		51	Cable Hold Down Bracket
		52	Lineshaft end Kit Assembly End cover Guard 1/4" X 1/2" Whiz Lock Screw 1/4" Steel Spring Nut

Specify Unit Serial Number when ordering replacement parts to ensure proper allocation of components (See Ordering Replacement Parts on page 12).

Recommended Spare Parts are shown in red. Charted are item no. and part description

When ordering use example below.

Example: Need a replacement drive collar (S12798) for a Intermediate SZ738LSZ Bed Section with 1.5" Roller Centers.

Part No: SN 123456 - 1 - Drive Collar



**ROACH CONVEYORS**  
 808 HIGHWAY 463  
 TRUMANN, AR 72472  
 TEL. 870-483-7631

---

SERIAL NO. 123456

# PARTS LIST FOR LINE SHAFT CONVEYORS INTERMEDIATE SZ738LSZI BED SECTION 1.5" ROLLER CENTERS

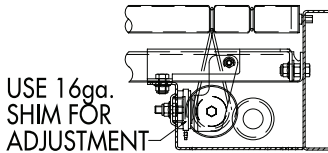
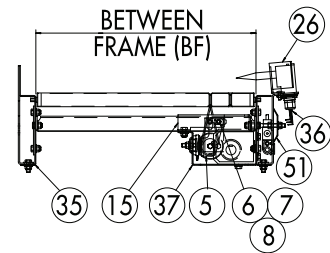
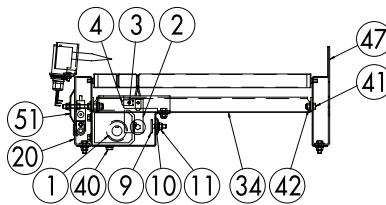
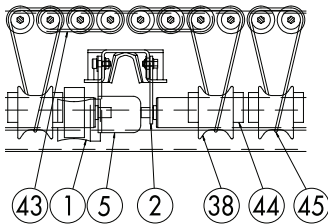
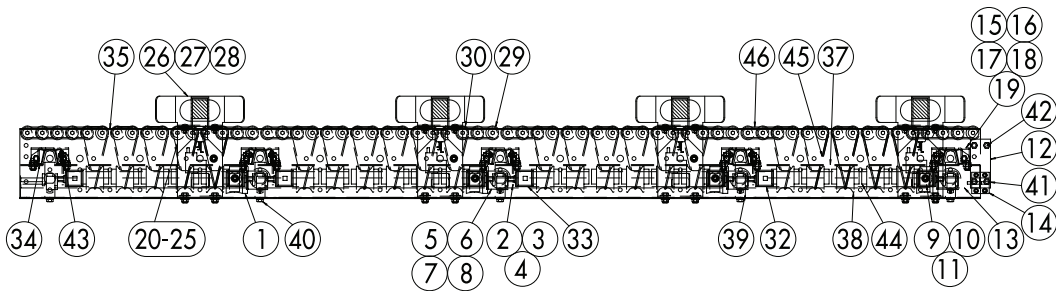
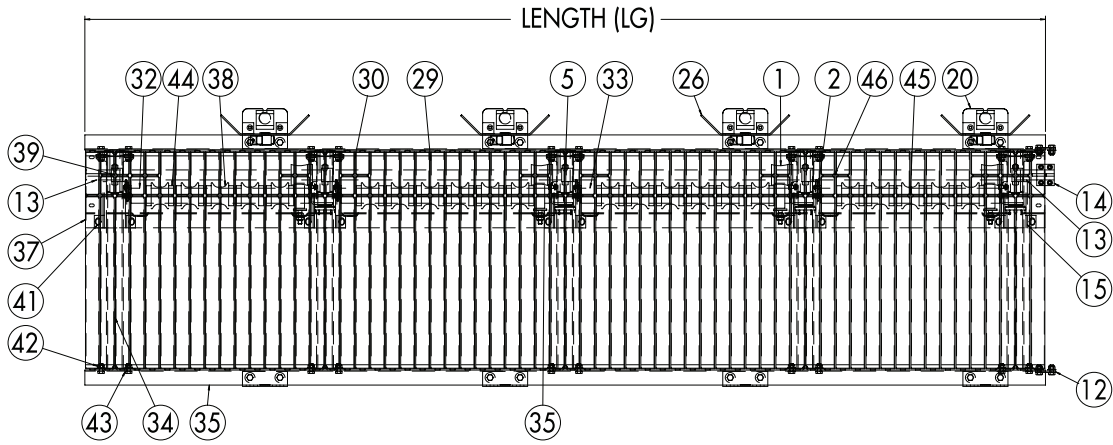

BOTTOM GUARD IS TO BE ADJUSTED IN SO BRAKE BOLT IS 1/16" FROM DRIVE WHEEL WHEN ZONE ROLLER IS ENGAGED OR TOUCHING DRIVE COLLAR.

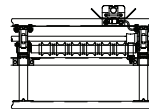

END KIT ASSEMBLY

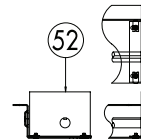

SZ738LSZI will have counterclockwise twist on drive bands standard.

# PARTS LIST FOR LINE SHAFT CONVEYORS INTERMEDIATE SZ738LSZI BED SECTION 3" ROLLER CENTERS

ITEM #	DESCRIPTION	ITEM #	DESCRIPTION
1	Drive Collar (S12798)	33	156G Zone Drive Roller Assembly (Ends Only) (156G-BF-A-ZDR) Located At Each End Only Per Bed Section 18" Zone Roller BF 12-3/8" 24" Zone Roller BF 18-3/8" 30" Zone Roller BF 24-3/8" 36" zone Roller BF 30-3/8"
2	Roller Stationary Bracket		
3	1/4"-20 X 1-2"LG Whiz Lock Screw		
4	1/4" Steel Spring Nut		
5	Roller Actuator Bracket LH		
6	5/16" X 1/4" X 1/4"-20 SHSS		
7	5/16" 18-8 S.S. Flat Washer		
8	1/4"-20 Flange Nut	34	156G Zone Drive Roller Assembly (Mid Only) (156G-BF-A-ZDR) Located Between End Rollers per Bed Section 18" Zone Roller BF 15-3/8" 24" Zone Roller BF 21-3/8" 30" Zone Roller BF 27-3/8" 36" Zone Roller BF 33-3/8"
9	Brake Pad Bolt (3/8"-16 X 1-1/2"LG)		
10	3/8" Hex Jam Nut		
11	3/8" Nylon Inset Smooth Flange Nut		
12	Lineshaft Splice Plate		
13	Mainline Drive Shaft (24"-120")	35	SZ796LSZ Frame Cross Brace
14	Coupling Assembly (A38222)	36	Side Channel (24"-120")
15	Pivot Mount	37	Smartzone® Plumbing Kit Smartzone® Photo Eye Smartzone® Valve
16	3/8" X 1-1/4"LG. HHCS		
17	3/8" Hex Nut		
18	3/8" Flat Washers	38	Intermediate Bed Guard (24"-120")
19	3/8" Nylon Insert Smooth Flange Nut	39	Lineshaft Spool (BRW04608)
20	Smartzone® Mounting Bracket	40	Lineshaft Pillow Block Bearing (BRW04125)
21	3/8" X 3"LG. HHTB	41	3/8"-16 X 1/2" Hex Washer Head flange Bolt
22	3/8" Flat Washers	42	3/8" X 3/4"LG. HHCS
23	3/8" Hex Nut	43	3/8" Nylon Insert Smooth Flange Nut
24	3/8" X 3/4"LG. HHCS	44	3/8" Flat Washers
25	3/8" Nylon Insert Smooth Flange Nut	45	Spool Spacer (MCW06432)
26	Smartzone® Guard	46	1/8" Dia. X 12-3/4"LG. Clear Drive Belt (VBW71382)
27	1/4"-20 X 3/4"LG Carriage Bolt	47	1/8" Dia. X 8-1/4"LG. Clear Slavebelt (VBW71379)
28	1/4"-20 Flange Nut	48	Cable Hold Down Bracket
29	138 Grooved Roller Assembly @4.5 (138G-BF-F-G1C)	49	Lineshaft end Kit Assembly End cover Guard 1/4" X 1/2" Whiz Lock Screw 1/4" Steel Spring Nut
30	138 Double Grooved Roller Assembly @ 2.5 , 4 (138G-BF-F-G2C)		
31	138 Grooved Roller Assembly @ 2.5 (138G-BF-F-G1A)		
32	156G Zone Drive Roller Assembly (Single Only) (156G-BF-A-ZDR) 24" Zone Roller BF 15-3/8" 30" Zone Roller BF 21-3/8" 36" Zone Roller BF 27-3/8"		

Specify Unit Serial Number when ordering replacement parts to ensure proper allocation of components (See Ordering Replacement Parts on page 12).

Recommended Spare Parts are shown in red. Charted are item no. and part description

When ordering use example below.

Example: Need a replacement drive collar (S12798) for a Intermediate SZ738LSZ Bed Section with 3" Roller Centers.

Part No: SN 123456 - 1 - Drive Collar



# PARTS LIST FOR LINE SHAFT CONVEYORS INTERMEDIATE SZ738LSZI BED SECTION 3" ROLLER CENTERS

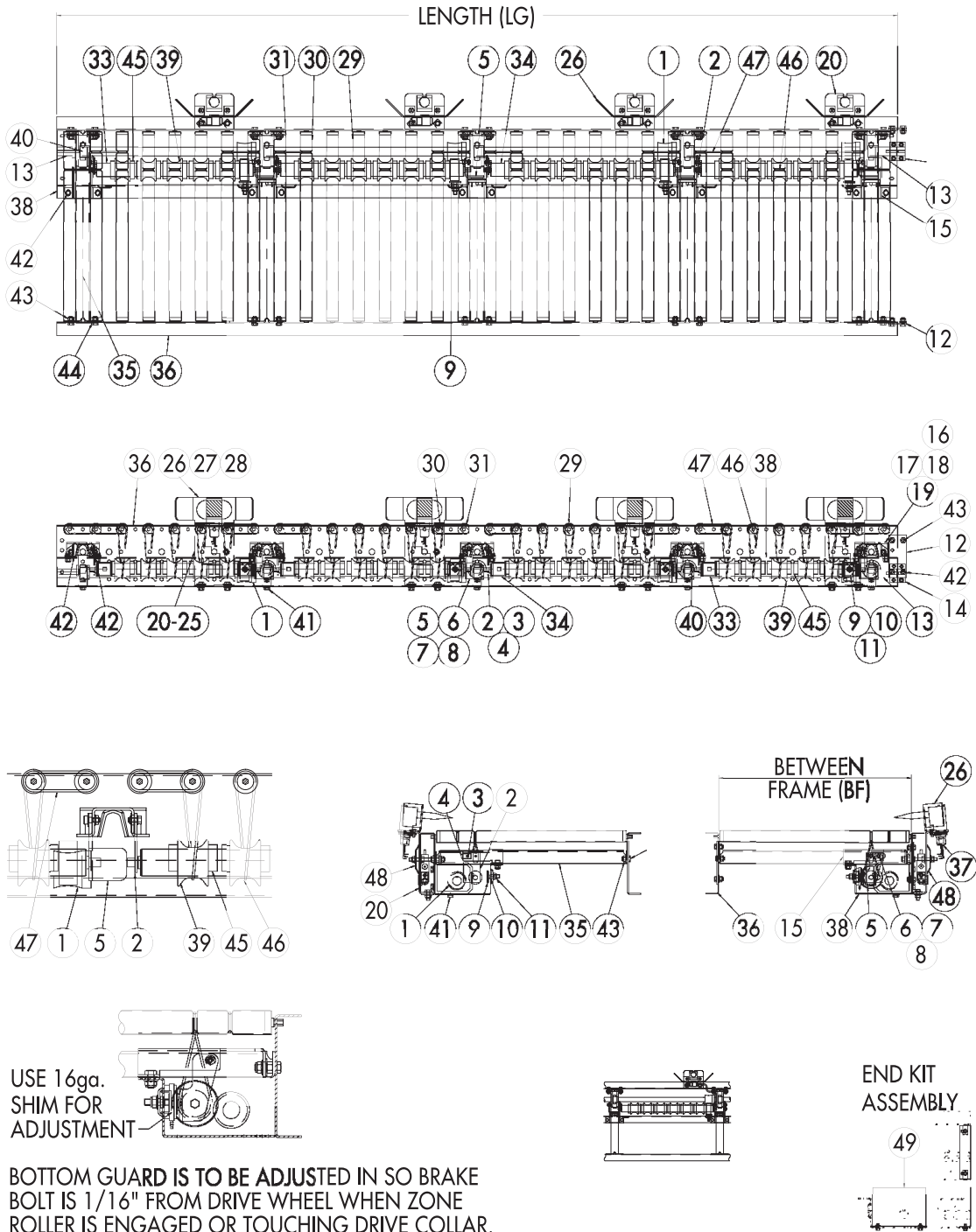

SZ738LSZI will have counterclockwise twist on drive bands standard.



# PARTS LIST FOR LINE SHAFT CONVEYORS SZ796LSZ BED SECTION

ITEM #	DESCRIPTION	ITEM #	DESCRIPTION
1	Drive Collar (S12798)	38	156G Zone Drive Roller Assy (Ends Only) (156G-BF-A-ZDR) Located At Each End Only Per Bed Section 18" Zone Roller BF 12-3/8" 24" Zone Roller BF 18-3/8" 30" Zone Roller BF 24-3/8" 36" Zone Roller BF 30-3/8"
2	Roller Stationary Bracket		
3	1/4"-20 X 1/2"LG Whiz Lock Screw		
4	1/4" Steel Spring Nut		
5	Roller Actuator Bracket LH		
6	5/16" X 1/4" X 1/4" -20 SHSS		
7	5/16" 18-8 S.S. Flat Washer	39	156G Zone Drive Roller Assembly (Mid Only) (156G-BF-A-ZDR) Located Between End Rollers Per Bed Section 18" Zone Roller BF 15-3/8" 24" Zone Roller BF 21-3/8" 30" Zone Roller BF 27-3/8" 36" Zone Roller BF 33-3/8"
8	1/4"-20 Flange Nut		
9	Brake Pad Bolt (3/8"-16 X 1-1/2"LG)		
10	3/8" Hex Jam Nut		
11	3/8" Nylon Insert Smooth Flange Nut		
12	Lineshaft Splice Plate		
13	Main-line Drive Shaft (24"-120")	40	Drive Shaft End Cover
14	Coupling Assembly (A38222)	41	SZ796LSZ Frame Crossbrace
15	1/4"SQ X 7/8" LG Keystock	42	Side Channel (24"-120")
16	Reducer Spacer Channel	43	Smartzone® Plumbing Kit Smartzone® Photo Eye Smartzone® Valve
17	Drive Bed End Section Guard		
18	1/4"-20 X 1/2"LG Whiz Lock Screw		
19	1/4"-20 Flange Nut	44	Drive Bed Guard (24"-120")
20	Pivot Mount	45	796 Lineshaft Zone Accumulator Drive Kit Reducer Space Plate Chain Guard Top Cover L.H. Chain Guard Filler L.H. Chain Guard Cover Reducer Push Plate Motorbase Plate Motorbase Stiffener Assembly
21	3/8" X 1-1/4"LG HHCS		
22	3/8" Hex Nut		
23	3/8" Flat Washers		
24	3/8" Nylon Insert Smooth Flange Nut		
25	Smartzone® Mounting Bracket		
26	3/8" X 3"LG HHTB		
27	3/8" Flat Washers		
28	3/8" Hex Nut	46	Lineshaft Spool (BRW04608)
29	3/8" X 3/4"LG HHCS	47	Lineshaft Pillow Block Bearing (BRW04125)
30	3/8" Nylon Insert Smooth Flange Nut	48	3/8"-16 X 1/2" Hex Washer Head Flange Bolt
31	Smartzone® Guard	49	3/8" X 3/4" LG. HHCS
32	1/4"-20 X 3/4"LG Carriage Bolt	50	3/8" Nylon Insert Smooth Flange Nut
33	1/4"-20 Flange Nut	51	3/8" Flat Washers
34	196 Grooved Roller Assembly @4.5 (196S-BF-A-G1C)	52	Spool Spacer (MCW06432)
35	196 Double Grooved Rollers Assembly @2.5, 4.5 (196S-BF-A-G2C)	53	3/16" Dia. X 13" LG. Clear Drive Belt (VBW71364)
36	196 Grooved Roller Assembly @2.5 (A37089-BF)	54	3/16" Dia. X 9-1/4" LG. Blue Slave Belt (VBW71366)
37	156G Zone Drive Roller Assy. (Single Only) (156G-BF-A-ZDR) 24" Zone Roller BF 15-3/8" 30" Zone Roller BF 21-3/8" 36" Zone Roller BF 27-3/8"	55	Cable Hold Down Bracket
		56	Lineshaft End Kit Assembly End Cover Guard 1/4" x 1/2" Whiz Lock Screw 1/4" Steel Spring Nut

Specify Unit Serial Number when ordering replacement parts to ensure proper allocation of components (See Ordering Replacement Parts on page 12).

Recommended Spare Parts are shown in red. Charted are item no. and part description

When ordering use example below.

Example: Need a replacement drive collar (S12798) for a SZ738LSZ  
Bed Section.  
Part No: SN 123456 - 1 - Drive Collar



**ROACH CONVEYORS**  
 808 HIGHWAY 463  
 TRUMANN, AR 72472  
 TEL. 870-483-7631

SERIAL NO.      123456

# PARTS LIST FOR LINE SHAFT CONVEYORS SZ796LSZ BED SECTION

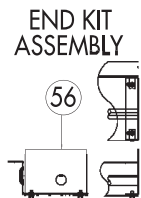
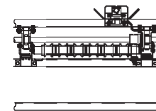
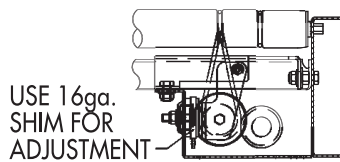
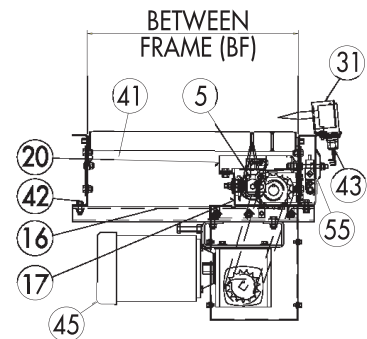
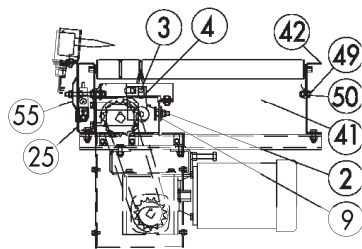
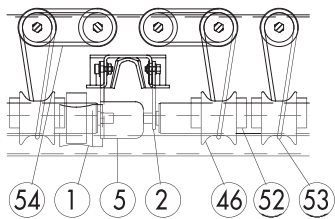
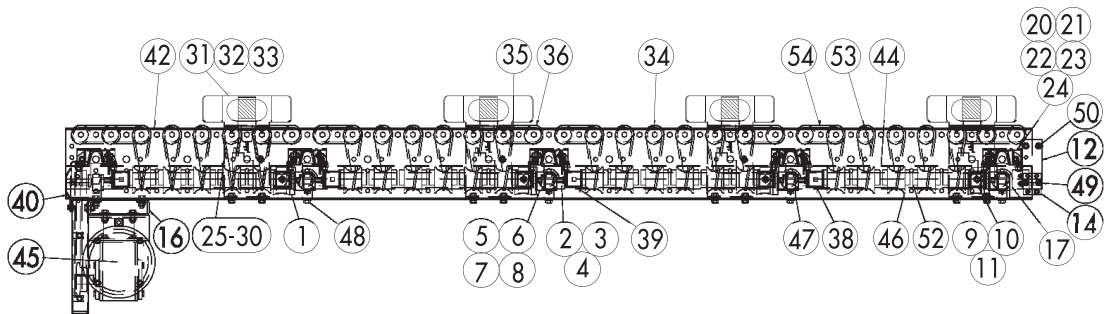
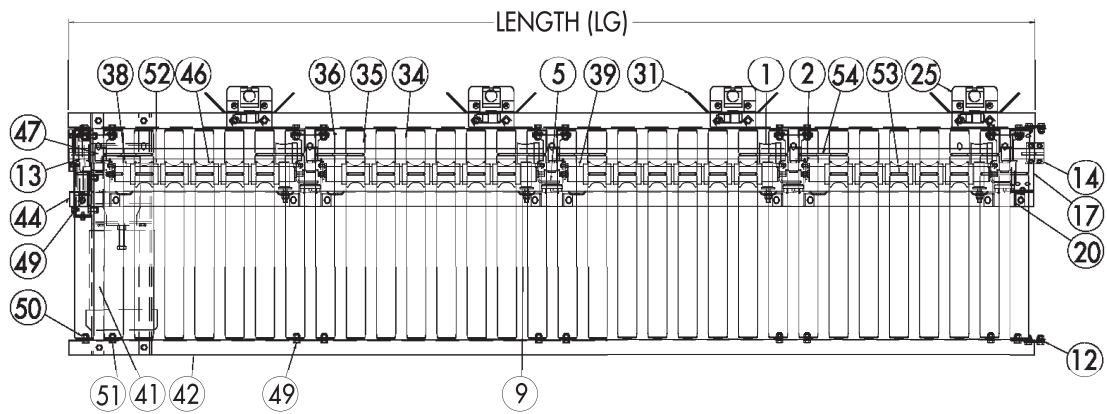

BOTTOM GUARD IS TO BE ADJUSTED IN SO BRAKE BOLT IS 1/16" FROM DRIVE WHEEL WHEN ZONE ROLLER IS ENGAGED OR TOUCHING DRIVE COLLAR.

SZ796LSZ will have counterclockwise twist on drive bands standard.

# PARTS LIST FOR LINE SHAFT CONVEYORS SZ796LSZI BED SECTION

ITEM #	DESCRIPTION	ITEM #	DESCRIPTION
1	Drive Collar (S12798)	33	156G Zone Drive Roller Assembly (Ends Only) (156G-BF-A-ZDR) Located At Each End Only Per Bed Section 18" Zone Roller BF 12-3/8" 24" Zone Roller BF 18-3/8" 30" Zone Roller BF 24-3/8" 36" zone Roller BF 30-3/8"
2	Roller Stationary Bracket		
3	1/4"-20 X 1-2"LG Whiz Lock Screw		
4	1/4" Steel Spring Nut		
5	Roller Actuator Bracket LH		
6	5/16" X 1/4" X 1/4"-20 SHSS		
7	5/16" 18-8 S.S. Flat Washer	34	156G Zone Drive Roller Assembly (Mid Only) (156G-BF-A-ZDR) Located Between End Rollers per Bed Section 18" Zone Roller BF 15-3/8" 24" Zone Roller BF 21-3/8" 30" Zone Roller BF 27-3/8" 36" Zone Roller BF 33-3/8"
8	1/4"-20 Flange Nut		
9	Brake Pad Bolt (3/8"-16 X 1-1/2"LG)		
10	3/8" Hex Jam Nut		
11	3/8" Nylon Inset Smooth Flange Nut		
12	Lineshaft Splice Plate		
13	Mainline Drive Shaft (24"-120")	35	SZ796LSZ Frame Cross Brace
14	Coupling Assembly (A38222)	36	Side Channel (24"-120")
15	Pivot Mount	37	Smartzone® Plumbing Kit Smartzone® Photo Eye Smartzone® Valve
16	3/8" X 1-1/4"LG. HHCS		
17	3/8" Hex Nut		
18	3/8" Flat Washers	38	Intermediate Bed Guard (24"-120")
19	3/8" Nylon Insert Smooth Flange Nut	39	Lineshaft Spool (BRW04608)
20	Smartzone® Mounting Bracket	40	Lineshaft Pillow Block Bearing (BRW04125)
21	3/8" X 3"LG. HHTB	41	3/8"-16 X 1/2" Hex Washer Head flange Bolt
22	3/8" Flat Washers	42	3/8" X 3/4"LG. HHCS
23	3/8" Hex Nut	43	3/8" Nylon Insert Smooth Flange Nut
24	3/8" X 3/4"LG. HHCS	44	3/8" Flat Washers
25	3/8" Nylon Insert Smooth Flange Nut	45	Spool Spacer (MCW06432)
26	Smartzone® Guard	46	3/16" Dia. X 13"LG. Clear Drive Belt (VBW71364)
27	1/4"-20 X 3/4"LG Carriage Bolt	47	3/16" Dia. X 9-1/4"LG. Blue Slavebelt (VBW71366)
28	1/4"-20 Flange Nut	48	Cable Hold Down Bracket
29	196 Grooved Roller Assembly @4.5 (196S-BF-A-G1C)	49	Lineshaft end Kit Assembly End cover Guard 1/4" X 1/2" Whiz Lock Screw 1/4" Steel Spring Nut
30	196 Double Grooved Roller Assembly @ 2.5 , 4.5 (196S-BF-A-G2C)		
31	196 Grooved Roller Assembly @ 2.5 (A37089-BF)		
32	156G Zone Drive Roller Assembly (Single Only) (156G-BF-A-ZDR) 24" Zone Roller BF 15-3/8" 30" Zone Roller BF 21-3/8" 36" Zone Roller BF 27-3/8"		

Specify Unit Serial Number when ordering replacement parts to ensure proper allocation of components (See Ordering Replacement Parts on page 12).

Recommended Spare Parts are shown in red. Charted are item no. and part description

When ordering use example below.

Example: Need a replacement drive collar (S12798) for a Intermediate SZ738LSZI Bed Section with 1.5" Roller Centers.

Part No: SN 123456 - 1 - Drive Collar

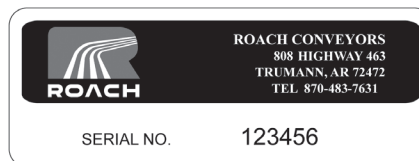

# PARTS LIST FOR LINE SHAFT CONVEYORS SZ796LSZI BED SECTION

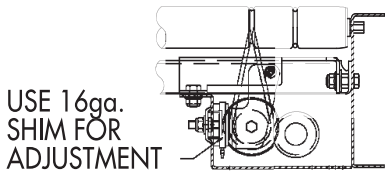
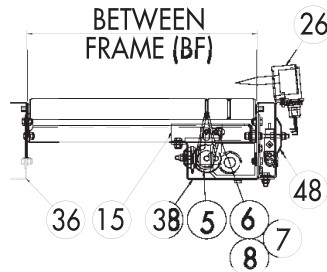
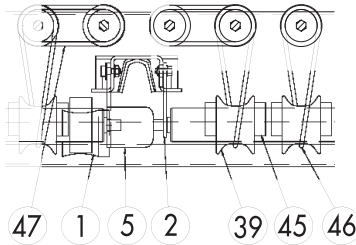
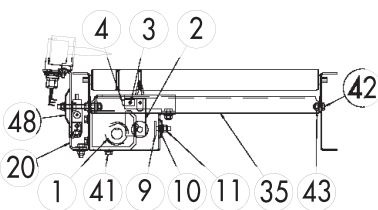
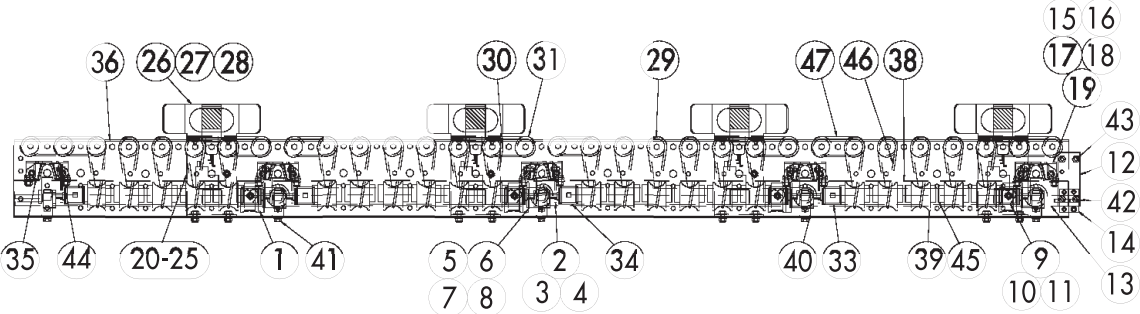
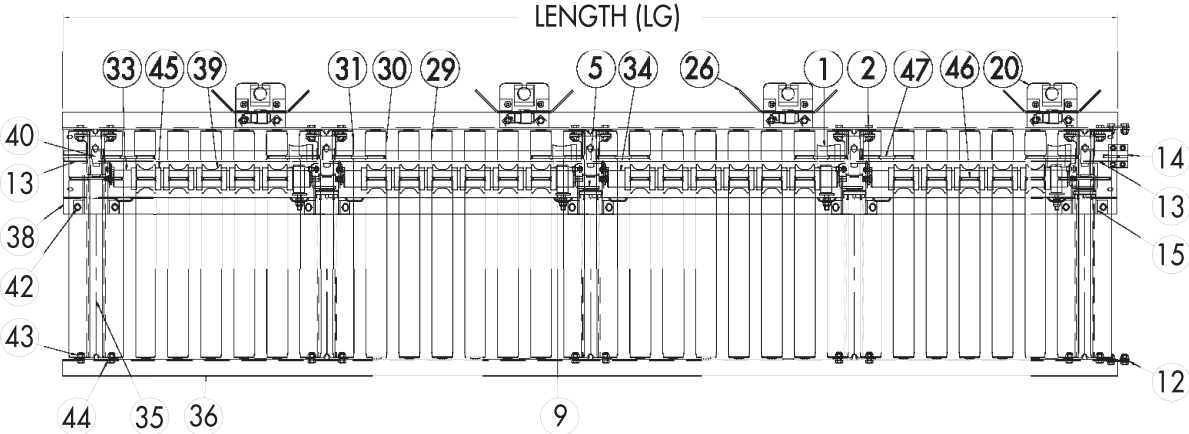

BOTTOM GUARD IS TO BE ADJUSTED IN SO BRAKE BOLT IS 1/16" FROM DRIVE WHEEL WHEN ZONE ROLLER IS ENGAGED OR TOUCHING DRIVE COLLAR.

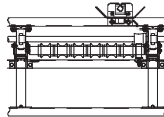

SZ796LSZI will have counterclockwise twist on drive bands standard.







# ROACH CONVEYORS

## WARRANTY

- Materials used by Roach Conveyors are of good quality.
- Any part proving to be defective in materials or workmanship upon Roach inspection, will be replaced at NO cost, FOB, Trumann, Arkansas, for one year. Installation expense will be paid by others.
- Roach liability includes furnishing said part or parts; Roach is not liable for consequential damages, such as loss of profit, delays or expenses incurred by failure of said part or parts.
- Failure due to abuse, incorrect adjustments, exposure to corrosive or abrasive environment or operation under damp conditions does not constitute failure due to defects in workmanship or materials.
- Component parts not manufactured by Roach (motors, gear reducers, etc.) will be repaired or replaced at the option of their manufacturer. Contact nearest authorized service center for all warranty claims.

NOTE: Motors or gear reducers tampered with before inspection shall be considered free of ALL Warranty Claims.

--All specifications are subject to change without notice--  
--Drawings are intended for illustration ONLY and are not to scale--

808 HIGHWAY 463  
TRUMANN, ARKANSAS 72472-1310  
Tel 870-483-7631 Fax 870-483-7049  
info@roachconveyors.com  
www.roachconveyors.com



**ROACH**  
**C O N V E Y O R S ®**

808 HIGHWAY 463  
TRUMANN, ARKANSAS 72472-1310  
Tel 870-483-7631 Fax 870-483-7049  
[info@roachconveyors.com](mailto:info@roachconveyors.com)  
[www.roachconveyors.com](http://www.roachconveyors.com)