

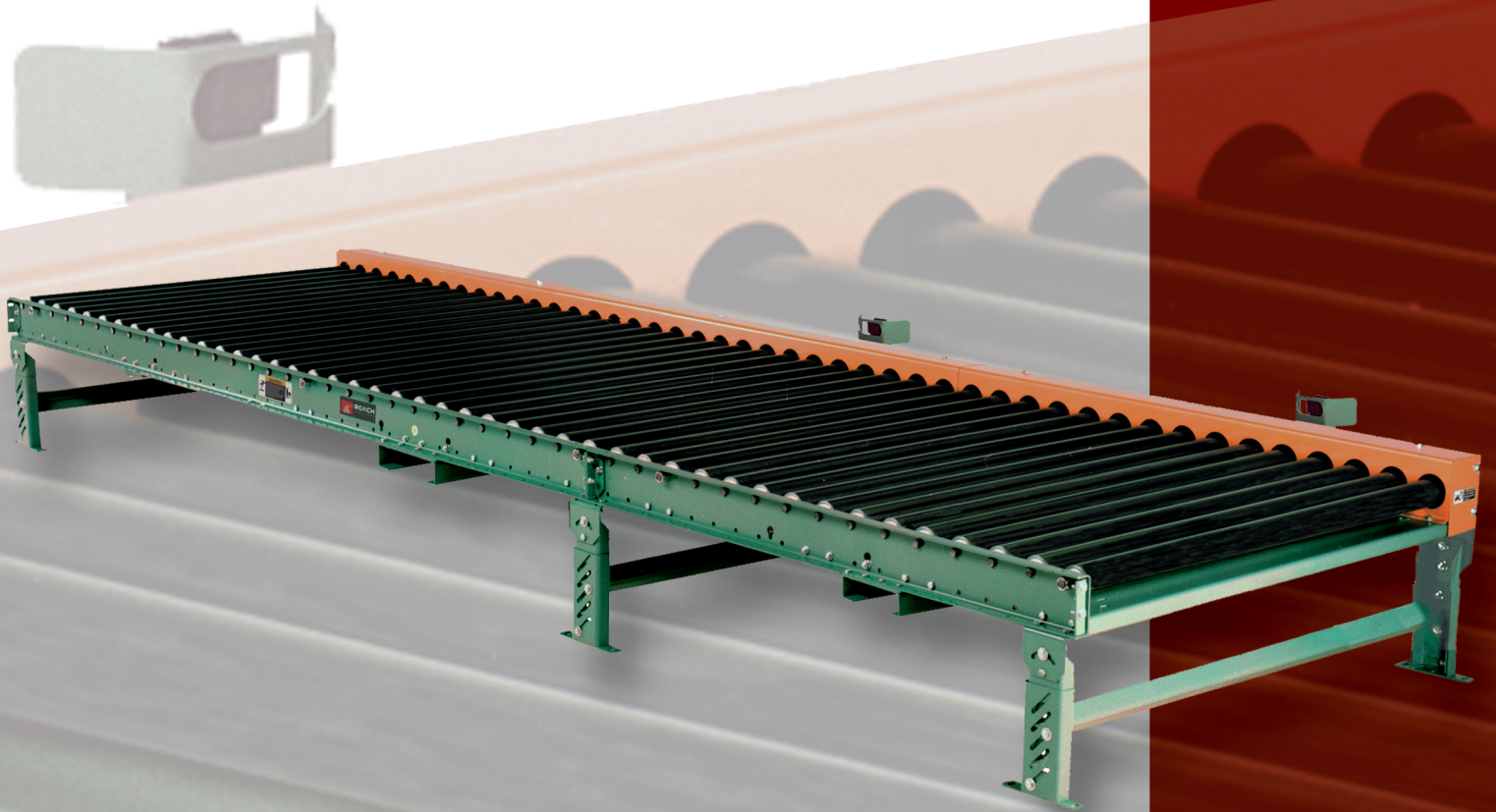

OWNER'S MANUAL



Smart Zone[®] Chain Driven Accumulators

Models SZD192CDA • SZD251CDA

DO NOT OPERATE BEFORE READING THIS HANDBOOK
KEEP IN A SAFE PLACE – DO NOT DISCARD

TECH HANDBOOK FOR CHAIN DRIVEN ACCUMULATORS

TABLE OF CONTENTS

CHAIN DRIVEN ACCUMULATORS TECH HANDBOOK	2	TROUBLE SHOOTING FOR ACCUMULATION MODE	12
-Warnings Labels.....	2	-Trouble Shooting / Serial Plate.....	12
CAUTIONS, WARNINGS AND HAZARDS	3	TROUBLE SHOOTING FOR DRIVE COMPONENTS	13
-Introduction.....	3	-Trouble Shooting.....	13
-Cautions, Warnings and Hazards.....	3	-Ordering Replacement Parts.....	13
SAFETY INFORMATION	4	MAINTENANCE SAFETY PRECAUTIONS	14
-Important Safety Guidelines.....	4	-Before Performing Maintenance.....	14
-Shortages, Damages and Return Authorizations.....	4	-Maintenance and Follow-Up Details.....	14
RECEIVING, INSPECTION & GENERAL INSTALLATION	5	MAINTENANCE AND LUBRICATION	15
-Uncrating.....	5	-Periodic Maintenance Schedule.....	15
-Attaching Bed Sections.....	5	-Recommended Lubricants.....	16
GENERAL INSTALLATION INFORMATION	6	-Report on Miscellaneous Maintenance Performed.....	16
-Couplings and Unit Squareness.....	6	START-UP PROCEDURES	17
-Identifying / Installing Permanent Floor Supports.....	6	-Gear Reducer w/ Posivent.....	17
START-UP PROCEDURES	7	-Preparing for Initial Start-up.....	17
-Drive Chain and Sprocket Alignment.....	7	PARTS LISTS	18
-Drive Chain and Sprocket Tension.....	7	-SZD192CDA (Side Mount Drive).....	18
TECHNICAL - SMART ZONE®	8	-SZD192CDA (Underneath Drive).....	19
-Smart Zone® Operation.....	8	-SZD251CDA (Side Mount Drive).....	20
-Smart Zone® Details.....	8	-SZD251CDA (Underneath Drive).....	21
-Smart Zone® Photo Sensor Details.....	9	NOTES	22
-Smart Zone® Slug Release Off-loading / Slug Loading.....	9	WARRANTY	23
-Power Supply Interface / Off-loading.....	10		
-Smart Zone® Operator-Controlled Work Zones (Optional).....	11		

WARNING LABELS



ABOVE: Label attached to all protective guards (drives, roller guards, etc.)



ABOVE: Label placed near all drive assemblies and at 30' intervals

CAUTIONS, WARNINGS AND HAZARDS

INTRODUCTION

This manual was prepared as a “how-to-guide” for installers, end-users and maintenance personnel. It is also intended to educate both owner (purchaser) and all individuals working around the unit, of potential hazards.

With proper installation and maintenance, conveyors are essential for achieving a variety of functions essential in today’s industrial marketplace. By following a simple, periodic maintenance schedule, the life of a typical conveyor (or, most any type of machinery--including our automobiles!) will increase when compared to a similar

unit in an application receiving little or no maintenance. You may find that a conveyor can become your best workplace friend by following simple safety guidelines. **Failure to follow even the most basic safety suggestions can result in serious personal injury.**

Conveyors contain many moving parts--pulleys, belting, chains, sprockets, shafts, rollers, etc. Therefore, it is imperative to become familiar with basic unit operation and know all points of potential hazards.

Remember, when working around or near conveyors (and **any** industrial machinery)

it is **your** responsibility to become familiar with the unit, to know potential hazards (many are noted with caution labels) and to operate unit in strict accordance with the safety guidelines in this manual.

Keep this manual in a safe place for future reference. It should be placed where appropriate personnel may maintain proper maintenance and records.







This manual must be read by all new users before operating or working near this unit.

 **WARNING**

DO NOT OPERATE BEFORE READING THIS MANUAL!
KEEP IN SAFE PLACE--DO NOT DISCARD!

CAUTIONS, WARNINGS AND HAZARDS

 **WARNING**

-  Always anchor permanent supports to floor (or mounting surface). Use 3/8" x 2-1/2" (or longer) wedge anchors for permanent installation in concrete flooring.
-  It is the responsibility of the customer and installation personnel to supply and install net or mesh guarding on overhead mounted conveyors to prevent product and/or debris from falling to floor in areas where required.
-  To check drive sprocket alignment, shut "OFF" and lock out power source before attempting any adjustments.
-  To check drive sprocket tension, shut "OFF" and lock out power source before any adjustments are attempted.
-  Center drive guards **MUST** be replaced after installation or maintenance.
-  Electrical controls must be designed by a qualified electrical engineer to ensure that appropriate safety features (emergency stops, pull cords, switches, etc.) are installed on unit for safe operation. Before conveyor start-up, all operators and other personnel coming in contact with unit must be properly trained and must have read accompanying Owners Manual.
-  Only trained personnel shall perform maintenance functions. Before maintenance operations are performed, shut conveyor "OFF" and lock out power source to prevent unauthorized start-up. When maintenance is completed, only authorized personnel shall be permitted to start conveyor following maintenance or other emergency shut-off.

SAFETY INFORMATION

IMPORTANT SAFETY GUIDELINES

! WARNING

WARNING: All personnel coming in contact with this conveyor should be aware of the following safety guidelines **BEFORE USING OR WORKING AROUND CONVEYOR**. **NOTE: ALWAYS** notify Roach Manufacturing® whenever any conveyor is used in an application or condition other than was originally intended. Failure to notify Roach® may allow conveyor to be operated in a hazardous operating condition. Injuries resulting from negligence or violation of safety instructions hereby removes responsibility of product liability claims from Roach®.

! Do not operate conveyor with protective guards removed. This includes chain guards, belt guards, snub roller guards, center drive guards and any other safety guard.

! Do not walk, ride, climb, or touch moving parts on a conveyor in operation.

! Do not wear loose clothing or uncovered hair around conveyor.

! Do not work near conveyor without knowing how & where to shut power "OFF" and lock out power source.

! Do not remove jammed product with conveyor running.

! Do not replace parts or perform maintenance on conveyor, or moving conveyor parts, without first shutting "OFF" power to conveyor and locking out power source.

! Do not connect gravity to powered conveyor without safety gravity connector brackets.

! To prevent electrical shock, conveyor must be grounded, and have proper electrical connections in accordance with federal, state, and local codes.

! Safety pop out rollers in conveyors installed above 7'-0" elevation must be retained by guard rail, clips, etc. Safety pop out rollers must be allowed to pop out

when conveyors are installed at or below 7'-0" elevation.

! It is the responsibility of conveyor end-user to comply with all safety standards including OSHA and other federal, state, and local codes or regulations. Install protective guarding and other related safety precautionary equipment to eliminate hazardous operating conditions which may exist when two or more vendors supply machinery for related use.

! Any violation of above safety instructions hereby removes all product liability claims from Roach Manufacturing Corporation®.

SHORTAGES, DAMAGES AND RETURN AUTHORIZATIONS

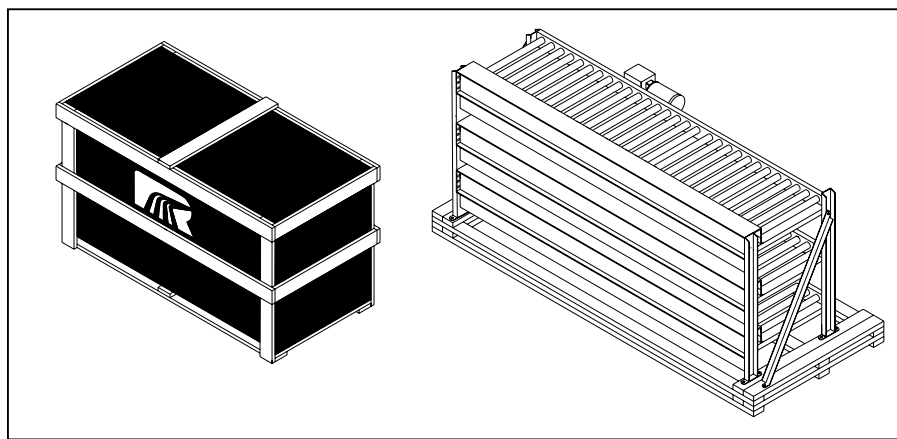

Before uncrating, check quantity of items received against bill of lading to confirm that all equipment has been received. Next, determine if any damage has occurred. Damage and/or shortage in shipment should be reported immediately to both Roach and carrier. Obtain signed damage report from carrier agent and send copy to Roach. **Do not repair any damage before obtaining this report.**

Finally, consult factory to determine if entire shipment must be returned to factory for repair **or** if a replacement order should be entered for replacement equipment.

Therefore, it is imperative that the bill of lading (or, accompanying freight documentation) be checked to ensure receipt of ALL units ordered including ALL accessories.

After receipt and initial inspection, care-

fully remove crating and look for essential components and specific accessories that may have been boxed and attached (or 'banded') to crating material such as guard rails and hardware which may be packaged and shipped in this manner. Save all hardware for subsequent use by installation personnel.

RECEIVING, INSPECTION & GENERAL INSTALLATION

UNCRATING

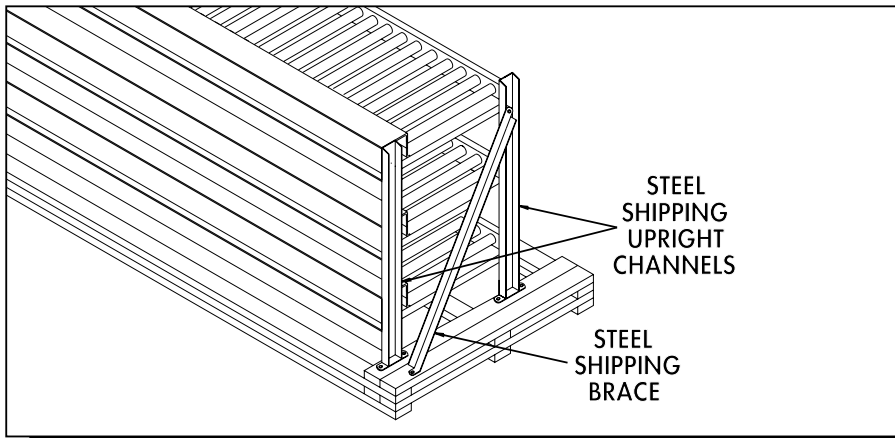

NOTE: Carefully examine shipment during uncrating to ensure that essential components are not discarded. This includes guard rail and other necessary hardware.

After receipt and initial inspection is completed, carefully remove crating and look for essential components and specific accessories that may have been boxed and attached (or 'banded') to crating material. Guard rails and hardware are often packaged and shipped in this manner. Save all hardware for subsequent use by installation personnel.

The drive section will be shipped mounted to its actual operating bed section. Intermediate bed sections are shipped on a common shipping pallet and are attached at the end of bed sections through unit butt couplings with heavy duty steel shipping upright channels.

Some items (electric motors, gearbox, etc.) may be shipped direct from their manufacturer to final destination. Thus, the conveyor may consist of two or more separate shipments.

ATTACHING BED SECTIONS

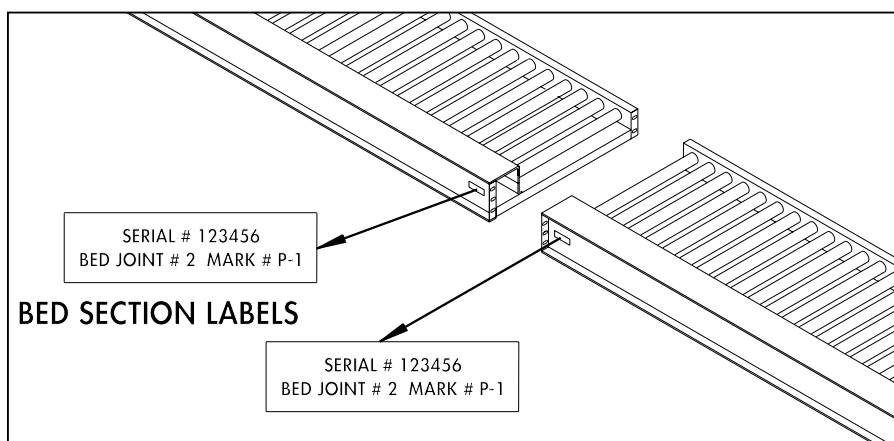

NOTE: It is critical for bed sections to be field assembled in proper sequence following bed section labels..

When preparing to install conveyor, first locate all component sections in the actual installation area. After uncrating, place unit bed sections conveying side up. Each bed section is marked to indicate proper sequence for mating (see illustration above for typical bed section labels).

It is critical for bed sections to be field assembled in proper sequence following

bed section labels. Refer to bed section drawing for location of supports and assemble as shown.

Conveyors are set up at the factory, bed section labels are applied, unit is test run and receives rigorous quality assurance inspection. At this time unit becomes field-ready. Therefore, it is critical that field installation personnel re-assemble unit

by mating beds in accordance with bed section labels (and bed section drawing).

Create a reference base line on floor by marking a chalk line along the centerline of conveyor. Follow base line when installing unit.

GENERAL INSTALLATION INFORMATION

COUPLINGS AND UNIT SQUARENESS

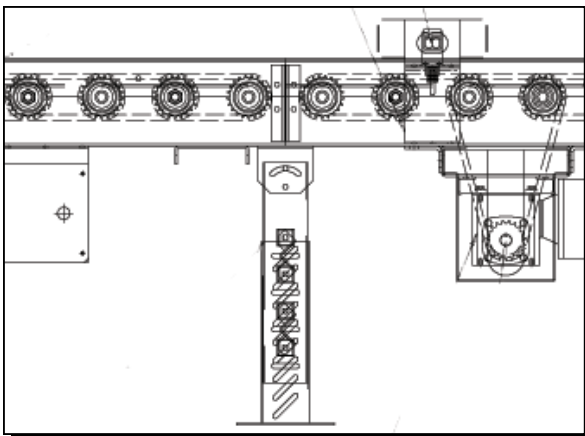

Use mechanical hoist (fork truck or other available means) to raise bed sections to approximate elevation to be installed. Mate intermediate sections with butt couplings to join bed sections (see illustration above).

One of the most critical elements of proper installation is unit squareness.

During unit installation, take diagonal measurement across unit and make adjustments as necessary to square unit prior to final assembly of supports. If conveyor is installed with beds not squared, packages will travel to one side of conveyor.

Permanent supports may be installed on conveyors at various locations. However,

NOTE: During unit installation, take diagonal measurement across unit and make adjustments as necessary to square unit prior to final assembly of supports.

it is most common to use single tier permanent floor supports at each end of a powered section (see illus. A below), where intermediate bed sections are adjoined (see illus. B below) and on heavy duty model, SZ251CDA at 5' intervals.

IDENTIFYING / INSTALLING PERMANENT FLOOR SUPPORTS

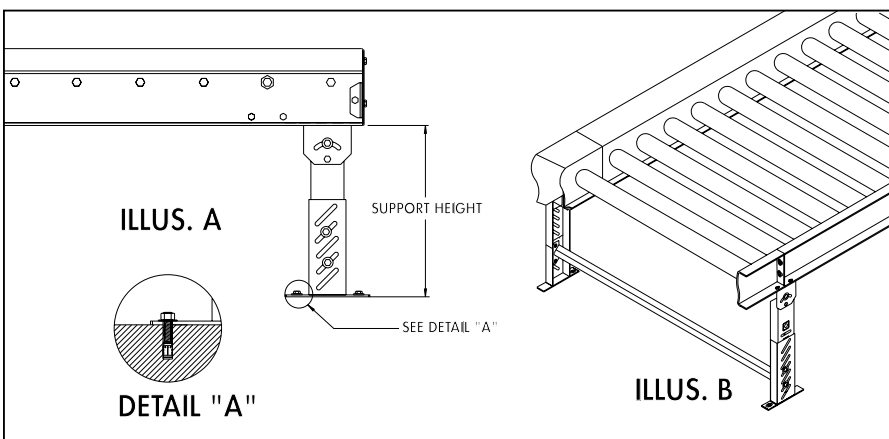

CAUTION: Always anchor permanent supports to floor (or mounting surface). Use 3/8" x 2-1/2" (or longer) wedge anchors for permanent installation in concrete flooring.

*MINIMUM SUPPORT HEIGHT FOR SM-CDA/SH-CDA					
SM (For 192CDA/SZ192CDA)			SH (For 251 CDA/SZ251 CDA)		
SM-1	7-1/4"	SM-7	34-1/4"	SM-1	6-1/4"
SM-2	10-1/4"	SM-8	46-1/4"	SM-2	7-3/4"
SM-3	13-1/4"	SM-9	58-1/4"	SM-3	10-3/4"
SM-4	16-1/4"	SM-10	70-1/4"	SM-4	13-3/4"
SM-5	20-1/4"	SM-11	80-1/4"	SM-5	16-3/4"
SM-6	24-1/4"	SM-12	92-1/4"	SM-6	19-3/4"
				SM-7	25-3/4"
				SM-8	31-3/4"
				SM-9	43-3/4"
				SM-10	55-3/4"
				SM-11	67-3/4"
				SM-12	79-3/4"

When installing permanent floor supports, notice that intermediate supports have two lag bolts in a diagonal pattern (see illus. B above) while end (terminal) supports have four lag bolts (see illus. A above), one in each of the four foot plate mounting holes.

When two (or more) powered conveyors are placed end-to-end, a single tier permanent support may be used at the end

junction commonly supporting both units. Check load rating of support before using this method of installation.

Adjust elevation to top of conveyor by loosening bolts in support uprights, raising or lowering conveyor and fully tightening bolts at desired elevation. Tighten all bolts in supports **before** unit operation.

Complete support installation by lagging

support attachment plates to floor (see detail "A"). Confirm that unit is level across width of conveyor before completing final support height adjustment.

*Supports are normally shipped at minimum support height. See chart above.

START-UP PROCEDURES

DRV. CHAIN AND SPRK ALIGNMENT/CHAIN TENSION ON U/N DRIVES

7

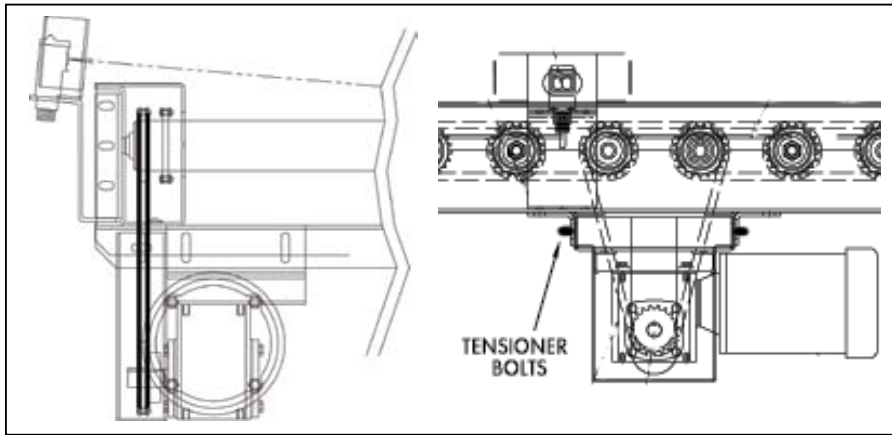

WARNING: To check drive sprocket alignment, it is imperative that conveyor is shut "OFF" and power source is locked out before any adjustments are attempted.

CHAIN GUARD REMOVED FOR CLARITY

WARNING: DO NOT OPERATE CONVEYOR WITH CHAIN GUARD REMOVED

Set up and maintenance of drive sprocket and drive chain alignment is critical. A periodic visual inspection is recommended to confirm alignment of drive components (which includes both drive sprockets and drive chain). Should set screws become loose, drive sprockets are subject to excessive wear and ultimately, to untimely replacement.

To check drive sprocket alignment, it is imperative that conveyor is shut "OFF" and power source is locked out before any adjustments are attempted. Remove chain guard cover and place straight-edge across face of both drive sprockets. If re-alignment is necessary, loosen set screws and adjust drive sprockets as required.

Remember to securely tighten set screws when alignment is complete.

Before replacing chain guard cover, check drive chain tension and adjust with tensioner bolt located on reducer push plate. Turn clockwise to tighten, counter-clockwise to loosen. Replace chain guard.

DRV. CHAIN AND SPRK ALIGNMENT/CHAIN TENSION ON S/M DRIVES

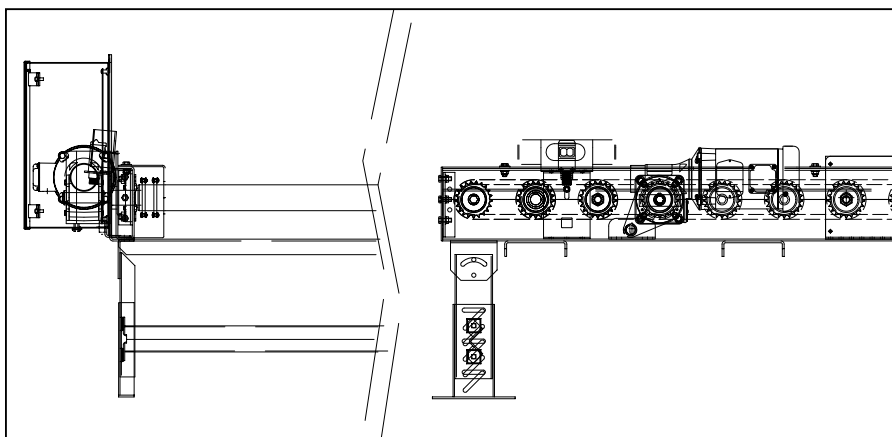

WARNING: To check drive sprocket tension, shut "OFF" and lock out power source before **any** adjustments are attempted.

CHAIN GUARD REMOVED FOR CLARITY

WARNING: DO NOT OPERATE CONVEYOR WITH CHAIN GUARD REMOVED

Set up and maintenance of drive sprocket and drive chain alignment is critical. A periodic visual inspection is recommended to confirm alignment of drive components (which includes both drive sprockets and drive chain). Should set screws become loose, drive sprockets are subject to excessive wear and ultimately, to untimely replacement.

To check drive sprocket alignment, it is imperative that conveyor is shut "OFF" and power source is locked out before any adjustments are attempted. Remove chain guard cover and place straight-edge across face of both drive sprockets. If re-alignment is necessary, loosen set screws and adjust drive sprockets as required.

Remember to securely tighten set screws when alignment is complete.

Before replacing chain guard cover, check drive chain tension and adjust with tensioner bolt located on reducer push plate. Turn clockwise to tighten, counter-clockwise to loosen. Replace chain guard.

TECHNICAL - SMART ZONE® SMART ZONE® OPERATION

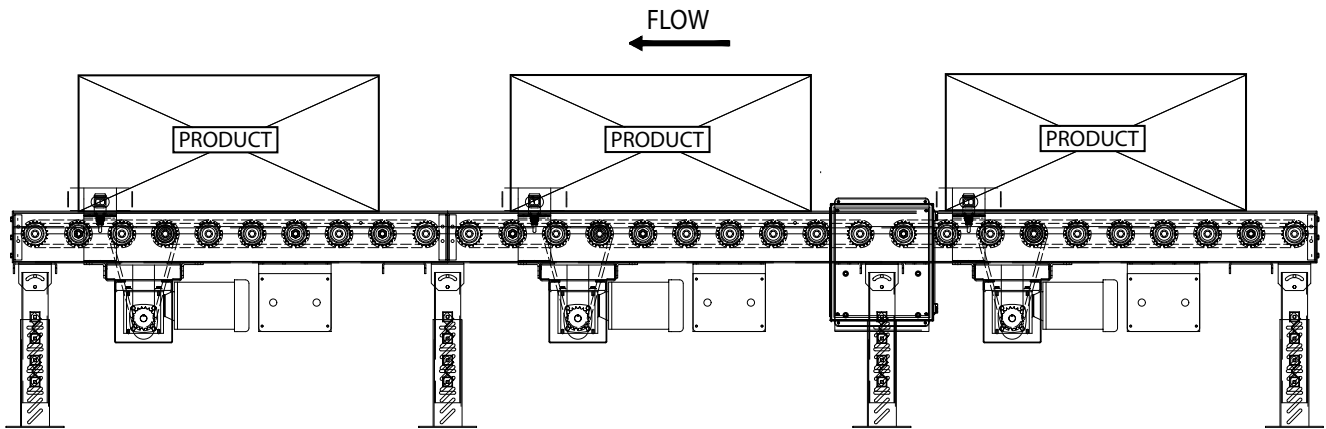

Roach Smart Zone® model SZD192CDA and SZD251CDA are zero pressure accumulation conveyors utilizing photo sensors to detect presence of product. Each requires photo sensor, reflector, starter and a motor in each zone. Also, a 24 volt DC power supply with 115/1 input voltage is required per conveyor, which is capable of powering up to 50 zones. The power supply delivers a low voltage signal to

each "daisy-chained" photo sensor and solenoid valve located in each accumulating zone.

Since Smart Zone® does not require physical package or carton weight to depress mechanical sensor, minimal weight objects can be accumulated.

Here's how Smart Zone® accumulates. The first package on the conveyor travels

until it blocks the photo sensor in discharge zone #1. The next package accumulates in zone #1 when it blocks the photo sensor in zone #2. The next package accumulates in zone #3 and so forth. This process is repeated for each successive Smart Zone®.

SMART ZONE® DETAILS

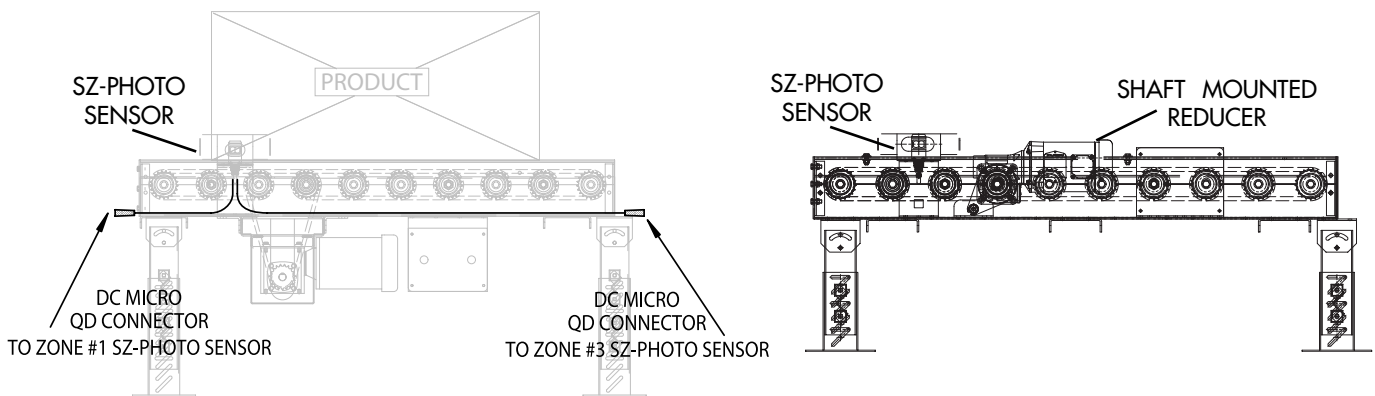

Photo sensors, reflectors, starters and motors are shipped mounted, connected and tested on Smart Zone®. When mating individual Smart Zone® bed sections during field installation, one simple connection is required, no tools required. Photo sensors must be adjoined across bed sections via DC micro QD connectors, a screw-type connection. A series of motors are used on

the Smart Zone® chain driven accumulation (CDA). The motors are mounted on the chain guard side. When a product blocks the Smart Zone® photoeye #1 in the discharge zone, a signal is delivered to interface box and disengages the motor driving the zone and shifts the zone into accumulation mode. The second product will stop moving when it blocks the Smart

Zone® photo eye in zone #2 and so forth. A product cannot accumulate in a zone until a product is accumulated in the adjacent discharge zone.

SMART ZONE® PHOTO SENSOR

EACH PHOTO SENSOR FEATURES BUILT-IN TIME DELAY OF 0-10 SECONDS. USE SCREWDRIVER IN SLOT SHOWN TO ADJUST REQUIRED TIME DELAY. TURN CLOCKWISE TO INCREASE TIME DELAY (10 SECONDS MAXIMUM).

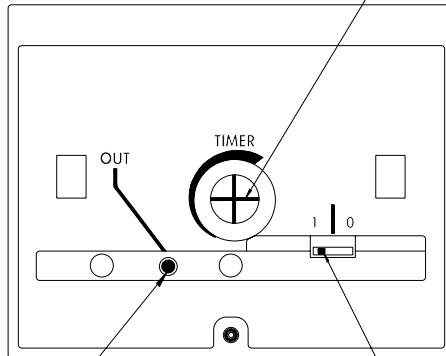

DIP SWITCH SHOULD ALWAYS BE SET TO POSITION 1 FOR MODEL CDA SMART ZONE®. THIS FEATURE DIRECTS SOLENOID VALVE TO ENERGIZE FOR PROPER OPERATION.

INDICATOR LIGHT INDICATES SOLENOID VALVE OUTPUT. SOLENOID VALVE IS ENERGIZED AND ZONE IS RUNNING WHEN INDICATOR LIGHT IS CONTINUOUSLY LIT. ZONE IS NOT RUNNING AND IS IN ACCUMULATION MODE WHEN LIGHT IS OUT.

SMART ZONE® SLUG RELEASE OFF-LOADING / SLUG LOADING

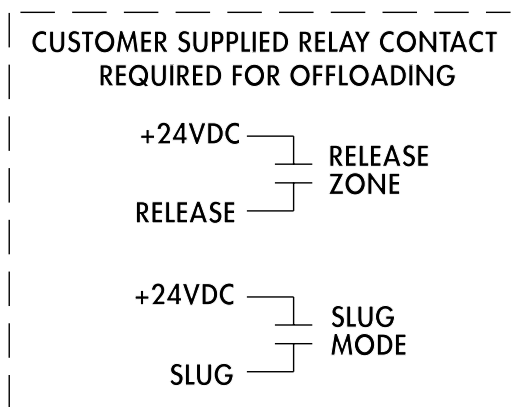

WARNING: Electrical controls must include appropriate safety features (emergency stops, pull cords, switches, etc.) installed on unit for safe operation. Before conveyor start-up, all operators and other personnel coming in contact with unit must be properly trained and must have read accompanying Tech Handbook.

A common feature for Smart Zone® conveyors is slug release or slug off-loading. When utilizing slug off-loading, all zones are powered at once to release all accumulated products. Likewise, once the slug mode is selected from Smart Zone® power supply via customer-supplied relay contact, the conveyor remains in slug mode for both slug off-loading and slug loading.

Slug loading allows a group or “slug” of products to accumulate on Smart Zone® at once. These products will continue in motion until either an additional sensor (not supplied with Smart Zone®) stops

Smart Zone® from continuously running or customer-supplied relay contact switches power supply from slug mode.

TECHNICAL - SMART ZONE® MAIN 3 PHASE DISCONNECT & 24V DC POWER SUPPLY

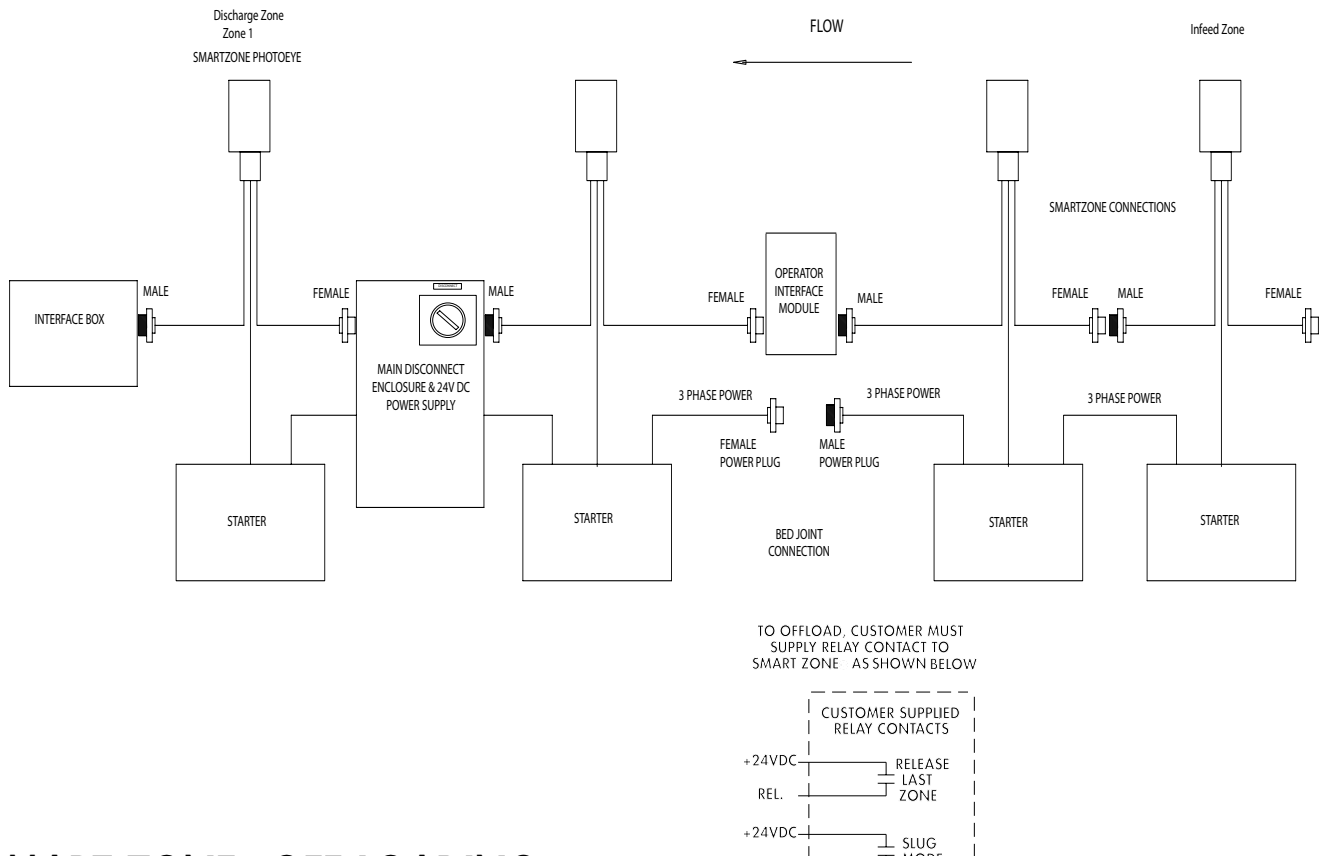

SMART ZONE® OFF-LOADING

The standard mode of operation for Roach Smart Zone® is zone singulation operation. The standard mode of product **release** for Smart Zone® is therefore, zone singulation release. Each product is accumulated in a separate zone on the conveyor. A product advances into the adjacent discharge zone when that zone is clear. The photo sensor clears and a single product advances.

To off-load utilizing standard zone singulation operation, operator uses a relay contact to the conveyor power supply to discharge a single product. The Smart Zone® power supply is a 100 watt 24VDC enclosure (refer to page 11 for more information on this power supply).

Finally, an operator may off-load Smart Zone® by simply removing a product from

the discharge zone, which allows another product to advance into the discharge zone when the previous product clears that zone. Advancement of second product can be delayed up to 10 seconds. The adjustable timer is standard in all smartzone photoeyes.

WARNING: Electrical controls must include appropriate safety features (emergency stops, pull cords, switches, etc.) installed on unit for safe operation. Before conveyor start-up, all operators and other personnel coming in contact with unit must be properly trained and must have read accompanying Tech Handbook.

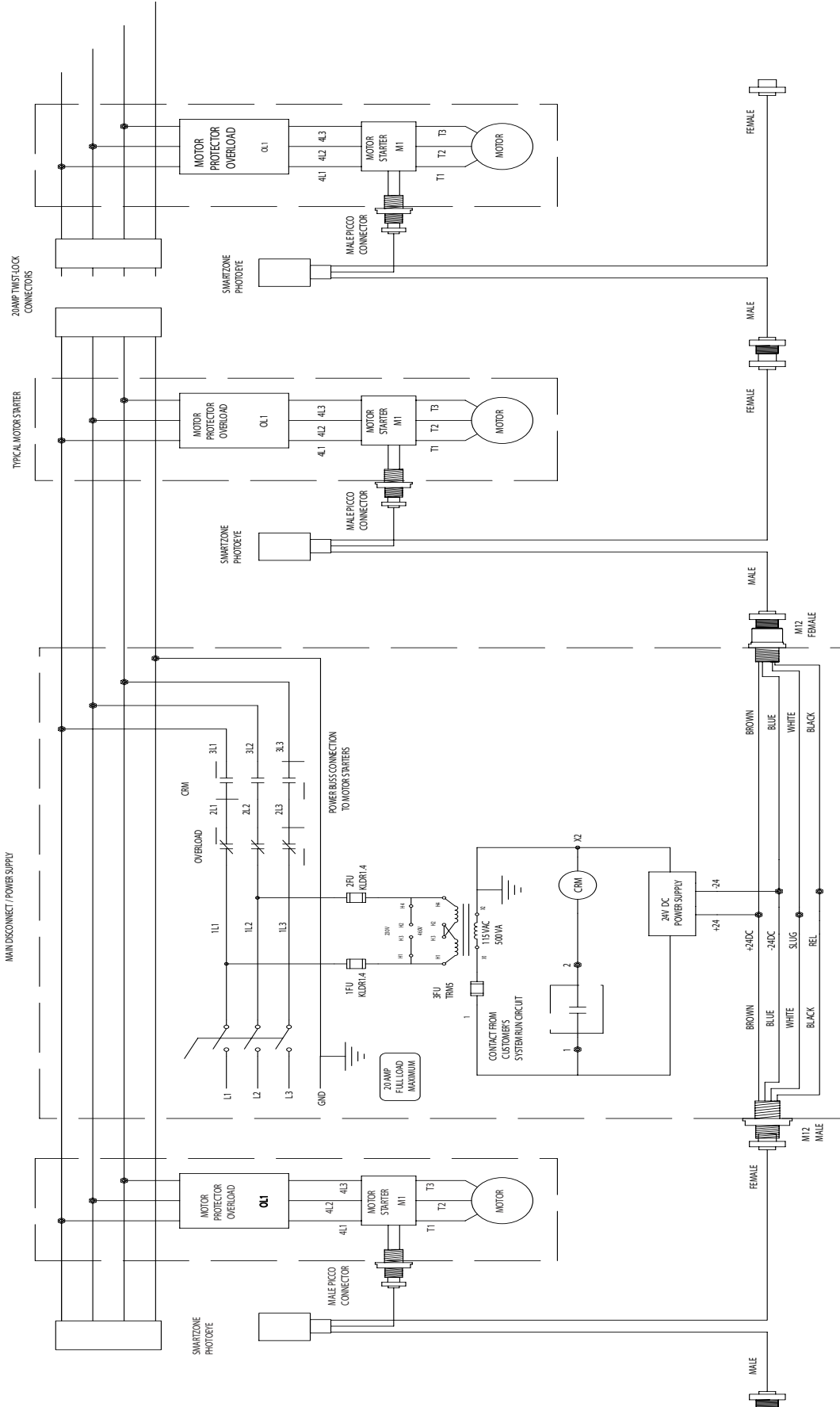

EACH OPERATOR-CONTROLLED WORK STATION REQUIRES INTERFACE WORK STATION BOX

TROUBLE SHOOTING FOR ACCUMULATION MODE

TROUBLE SHOOTING / SERIAL PLATE

TROUBLE SHOOTING FOR ACCUMULATION MODE	
TROUBLE	REMEDY
None of the zones are running	Check main 3 phase power. Check the power supply 24VDC indicator light is on. Check motor overloads.
None of the zones will stop	Make sure the system controls are not in slug mode.
Package stops in a zone and will not move into the down stream zone even though the down stream zone is empty	If the photoeye in the zone that is stopped does not have a green light, check the alignment of the photoeye in the empty zone. Make sure it is properly aimed at the reflector. If the photoeye in the zone that is not running has green light, check the solenoid valve.
Package will not stop at the discharge zone	Make sure the system controls are not keeping the discharge zone release input energized.
Package coasts through the zone but does not stop	Conveyor speed may be too high to allow product to coast to stop. A brake may be required.

SERIAL PLATE

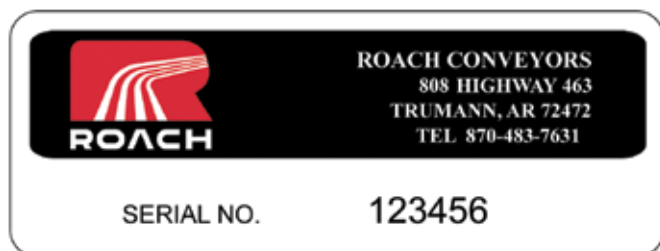

ORDERING REPLACEMENT PARTS

To order any replacement parts or when calling for assistance with any powered conveyor, **ALWAYS** provide the unit serial number. Shown at actual size, this aluminum plate is placed on the conveyor frame near the location of the drive assembly.

To order replacement parts or add-on components, contact the Roach distributor who originally furnished the unit if possible. If this is not possible, contact the national sales office at 870-483-7631 for the name of the authorized Roach distributor in your area. Have unit model number and serial number **BEFORE** calling. Refer to unit drawings (in rear section of handbook) for item no. and part description if ordering replacement parts.

TROUBLE SHOOTING FOR DRIVE COMPONENTS

TROUBLE SHOOTING

TROUBLE SHOOTING		
TROUBLE	PROBABLE CAUSE	REMEDY
Motor & gear reducer running excessively hot, repeated stalling or hard to start	A. Drag on conveyor B. Frozen sprocket C. Frozen roller D. Overload E. Electrical	A. Inspect entire conveyor for obstruction causing drag on chain. B. Check and inspect all sprockets and bearings. Replace sprockets failing to rotate or that are difficult to rotate. C. Check all rollers for rotation. D. Reduce cause and/or increase motor horsepower. E. Check wiring and circuits, take ampere reading, replace motor if necessary.
Motor & gear reducer makes excessive noise	A. Damaged gears B. Faulty bearing	A. Replace unit. B. Replace bearing.
Drive chain, conveying chain or sprockets experience excessive wear	A. Excessive chain tension B. Sprockets misaligned C. Chain not lubricated D. Damaged sprocket or chain E. Misalignment of chain guard F. Dirty chain	A. Reduce chain tension. B. Realign with straight edge across sprocket faces. C. Lubricate chain with approved lubricant, wipe away excess lubricant. D. Replace damaged component. E. Adjust chain guard assembly as necessary. F. Clean thoroughly and lubricate with approved lubricant.
Drive chain, conveying chain or sprockets make excessive noise	A. Insufficient chain tension B. Chain not adequately lubricated C. Sprockets misaligned	A. Adjust chain tension. B. Lubricate chain with approved lubricant, wipe away excess lubricant. C. Realign sprockets with straight edge across sprocket faces.
Pulsating chain	A. Insufficient chain tension B. Misalignment of chain guard C. Overload	A. Adjust chain tension. B. Adjust chain guard assembly as necessary. C. Inspect for obstruction to or drag on conveyor.
Broken chain	A. Frozen bearing or sprocket shaft B. Worn or damaged chain C. Obstructed or jam	A. Inspect for damaged bearings, replace if necessary. Replace links as required. B. Replace chain as required. C. Remove obstruction to clear jam.
Sprocket loose on shaft	A. Loose set screws B. Worn or damaged key	A. Realign sprockets with straight edge and tighten set screws. B. Replace with new key.
Excessive slack in chain	A. Normal wear	A. Expect rapid chain growth in first two weeks of operation. Adjust chain tension.

MAINTENANCE SAFETY PRECAUTIONS BEFORE PERFORMING MAINTENANCE

CAUTION: Only trained personnel shall perform maintenance functions. Before maintenance operations are performed, conveyor must be shut "OFF" and disconnects locked in the "OFF" position to prevent unit from unauthorized start-up.

One of the most important guidelines for maximizing conveyor operation and personnel safety is to implement a regular maintenance schedule and train personnel on the appropriate needs of the specific unit.

Only trained personnel shall perform maintenance functions. Before maintenance operations are performed, conveyor must be shut "OFF" and disconnects locked in the "OFF" position to prevent unit from unauthorized start-up during maintenance. All personnel should be informed of the safety procedures associated with unit maintenance and performance.

Do not perform any work on conveyors or conveyor system while

in operation unless it is impossible to otherwise conduct adjustment, lubrication or other maintenance function. Only experienced, trained personnel possessing advanced hazards-training should attempt such critical operations.

MAINTENANCE AND FOLLOW-UP DETAILS

CAUTION: Only trained personnel shall perform maintenance functions. When maintenance is completed, only authorized personnel shall be permitted to start conveyor following maintenance or other emergency shut-off.

While performing maintenance do not wear loose clothing. Immediately report any hazardous conditions--sharp edges, pinch (or nip) points or other conditions that may result when several manufacturers supply machinery which may create operating hazards.

When using mechanical aids such as hoists, cables, or cranes exercise extreme caution to prevent damage to conveyors or other integrated machinery which may create a working hazard when maintenance is completed and units are in operation.

Clean up any spilled lubricants or other materials used in the maintenance process or those which may be deposited during unit operation. Eliminating poor housekeeping practices increases unit efficiency while creating safer personnel working conditions.

After maintenance, conduct visual inspection to ensure that all safety devices and guards have been replaced. Confirm that all units are clear of tools, debris or other items. Before starting

conveyor, check condition of unit caution labels (see "CAUTION LABELS" at front of handbook). If labels have been destroyed or are not clearly legible, call 870.483.7631 to receive replacement labels. Placement of caution labels is critical to avoid unauthorized unit operation which may result in hazardous working conditions for all related personnel coming in contact with conveyor.

Warn personnel that conveyor is being prepared for start-up and to stay clear of unit. Do not start conveyor until all personnel are clear. When maintenance is completed, only authorized personnel shall be permitted to start conveyor following maintenance or other emergency shut-off.

MAINTENANCE AND LUBRICATION

PERIODIC MAINTENANCE SCHEDULE

MODEL NO. _____

WEEKLY RECOMMENDED MAINTENANCE SCHEDULE*	
COMPONENT	DETAIL OF MAINTENANCE
Bearings	Lubricate in dirty, dusty or moist/wet conditions.
Unit Safety Check	Confirm placement of all guards, warning labels & check for loose bolts, nip points & other hazards.

MONTHLY RECOMMENDED MAINTENANCE SCHEDULE*	
COMPONENT	DETAIL OF MAINTENANCE
Gear Reducer	Check for leaks.
Drive Sheaves	Check & re-tighten set screws & check for overall wear.
Pillow Block/Flange Bearings	Lubricate (normal conditions).
Drive Chain	Check for proper operating tension & for overall wear & lubricate.
Drive Sprockets	Check for overall wear & re-tighten set screws.

PERIODIC RECOMMENDED MAINTENANCE SCHEDULE*	
COMPONENT	DETAIL OF MAINTENANCE
Gear Reducer	Check for leaks.
Drive Chain	Clean (brush in solvent) & re-lubricate by applying lubricant to inside of chain with brush or spout can at 2000 hour intervals
Motor	Check & clear motor ventilation openings at 500 hour intervals. Check misc. operating conditions (normal heat & noise)

*All charts are for guidelines in normal operating or 'as noted' conditions. Severe applications may warrant additional maintenance.

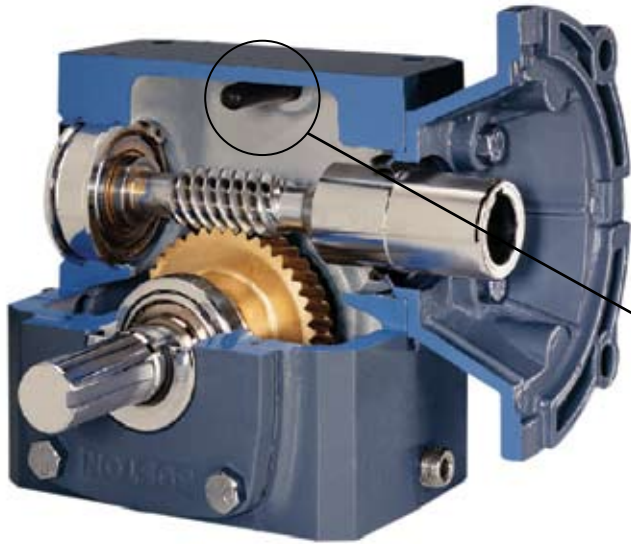

NOTE
The gear reducer is supplied with a "PosiVent[®]". No vent plugs are required.

PosiVent Unique design incorporates a single seam construction. Factory filled with synthetic lubrication for universal mounting. Lubed for life, no oil changes are required.

To expedite the installation and start-up process, all gear reducers are shipped filled with oil. The reducers are sealed and lubed for life and require no oil changes.

PREPARING FOR INITIAL START-UP



⚠ DANGER
WARN ALL PERSONNEL TO KEEP CLEAR OF CONVEYOR DURING UNIT START-UP
Electrical controls must be designed by a qualified electrical engineer to ensure that appropriate safety features (emergency stops, pull cords, switches, etc.) are installed on unit for safe operation. Before conveyor start-up, all operators and other personnel coming in contact with unit must be properly trained and must have read accompanying Tech Handbook.

Before conveyor start-up, all operators and other personnel coming in contact with unit must be properly trained and must have read accompanying Tech Handbook.

Provisions must be in order to instruct all personnel coming in contact with conveyor on the location of emergency stops, pull cords, etc.

A routine maintenance program should

be implemented before unit is placed into operation so that fundamental unit components are attended to. This maintenance program should include an inspection to ensure that any dangerous or hazardous operating conditions are noted and IMMEDIATELY corrected, as well as including electrical and mechanical unit inspections and corrections.

Finally, when conveyor is initially started, an immediate visual inspection should include motor, gear reducer, belt tracking (discussed in following section under "Belt Tracking") and related adjustments noted in handbook for unit/component corrections.

MODEL SZD192CDA

PARTS LIST FOR SIDE/SHAFT MOUNTED DRIVE

Specify **Unit Serial Number** when ordering replacement parts to ensure proper allocation of components (See Ordering Replacement Parts on page 12).
Recommended Spare Parts are shown in red. Charted are item no. and part description
 When ordering use example below.

Example: Need a replacement drive roller for a SZD192CDA with Side Mount Drive.

Part No: SN 123456 - 7 - Drive Roller Assembly



ITEM #	DESCRIPTION	ITEM #	DESCRIPTION
1	SZD192CDA Bed Section	14	Photoeye Mount
2	Chain Guard End Cover	15	Photoeye Guard
3	Drive Roller Clip Assembly	16	Motor Starter Assembly
4	Channel Crossmember	17	Enclosure Mounting Bracket
5	192S Tread Roller Assembly	18	1-3/16" Bore 3-Hole Bearing
6	192S Bed Spacer Roller Ass'y	19	#40 Chain
7	192S Drive Roller Assembly	20	GHM35030 1/2 HP Gearmotor
8	Bottom Chain Guard Top Chain Guard	21	Torque Arm Mounting Angle
9	6-1/2" Drive Side Channel	22	Power Supply Assembly
10	Butt Couplings	23	Power Supply Channel
11	4-1/2" Side Channel	24	Power Supply Stiffener Bracket
12	Bolt-in Butt Coupling	25	Support Assembly
13	Smart Zone Photocell		

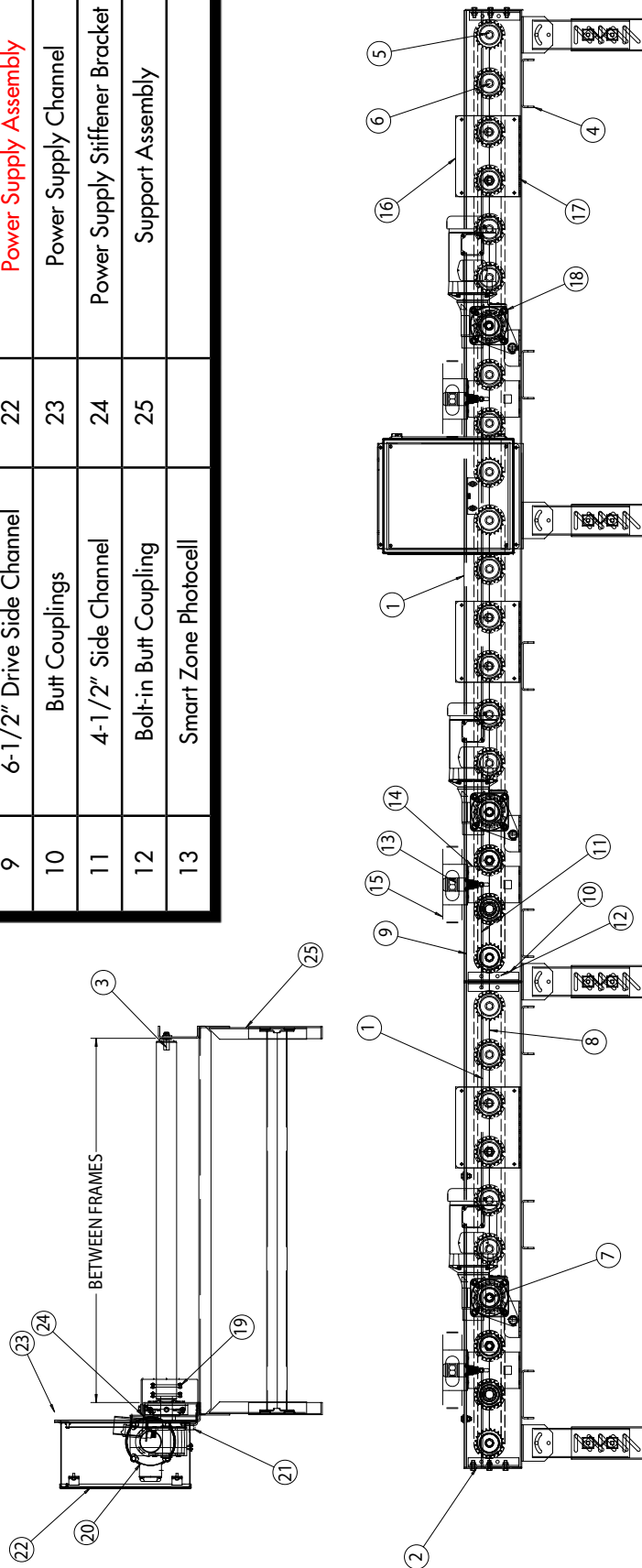

MODEL SZD192CDA PARTS LIST FOR UNDERNEATH DRIVE

Specify **Unit Serial Number** when ordering replacement parts to ensure proper allocation of components (See Ordering Replacement Parts on page 12).
Recommended Spare Parts are shown in red. Charted are item no. and part description
 When ordering use example below.

Example: Need a replacement drive sprocket for a SZD192CDA with Underneath Drive.

Part No: SN 123456 - 27 - Drive Sprocket

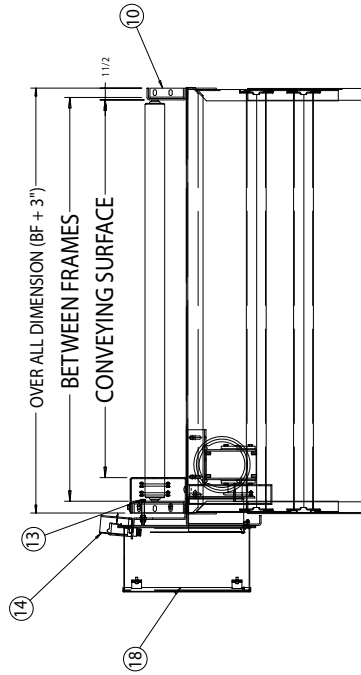
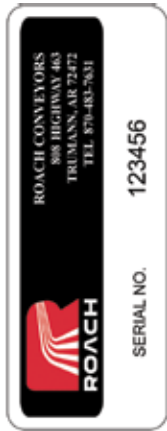

ITEM #	DESCRIPTION	ITEM #	DESCRIPTION
1	SZD192CDA Bed Section	15	Motor Starter Assembly
2	Chain Guard End Cover	16	Enclosure Mounting Bracket
3	Channel Crossmember	17	#40 Chain
4	192S Tread Roller Assembly	18	Power Supply Assembly
5	192S Bed Spacer Roller Ass'y	19	Power Supply Channel
6	Bottom Chain Guard Top Chain Guard	20	Power Supply Plate
7	6-1/2" Drive Side Channel	21	Motorbase Mounting Angle (LH/RH)
8	Butt Coupling	22	Reducer Base
9	4-1/2" Side Channel	23	Reducer Spacer and Mount
10	Butt Coupling	24	Chain Guard
11	Smart Zone Photocell Reflector Tape 2" Long	25	Motor
12	Photoeye Mount	26	Reducer
13	3/8" - 16 x 3" LG. Tap Bolt	27	Drive Sprocket
14	Photoeye Guard	28	Support Assembly

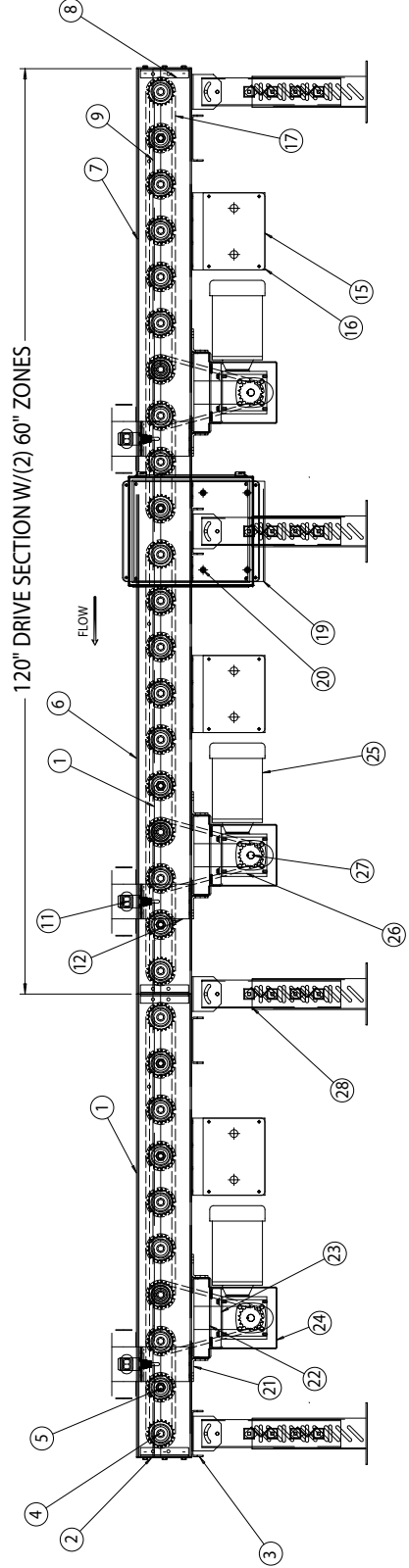

MODEL SZD251CDA

PARTS LIST FOR SIDE/SHAFT MOUNTED DRIVE

Specify **Unit Serial Number** when ordering replacement parts to ensure proper allocation of components (See Ordering Replacement Parts on page 12).
Recommended Spare Parts are shown in red. **Charted** are item no. and part description
 When ordering use example below.

Example: Need a replacement Support Assembly for a SZD251CDA with Side Mount Drive.

Part No: SN 123456 - 25 - Support Assembly

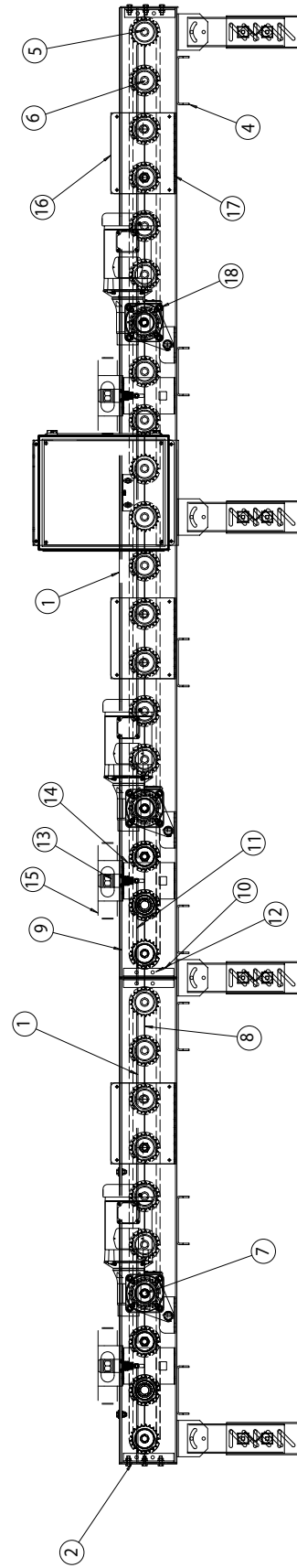
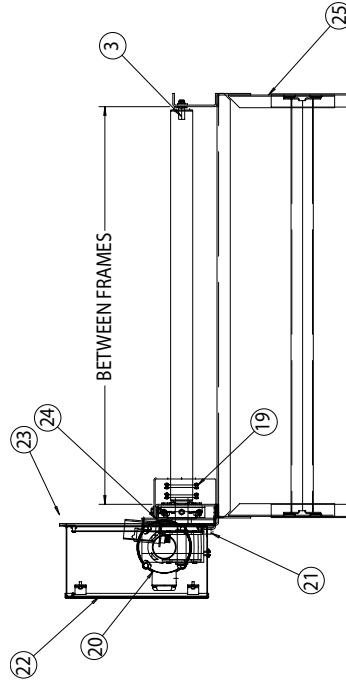

ITEM #	DESCRIPTION	ITEM #	DESCRIPTION
1	SZD251CDA Bed Section	14	Photoeye Mount
2	Chain Guard End Cover	15	Photoeye Guard
3	Drive Roller Clip Assembly	16	Motor Starter Assembly
4	Channel Crossmember	17	Enclosure Mounting Bracket
5	251S Tread Roller Assembly	18	1-7/16" Bore 4-Hole Bearing
6	251S Bed Spacer Roller Ass'y	19	#40 Chain
7	251S Drive Roller Assembly	20	GHM35030 1/2 HP Gearmotor
8	Bottom Chain Guard Top Chain Guard	21	Torque Arm Mounting Angle
9	7" Drive Side Channel	22	Power Supply Assembly
10	Butt Couplings	23	Power Supply Channel
11	5" Side Channel	24	Power Supply Stiffener Bracket
12	Bolt-in Butt Coupling	25	Support Assembly
13	Smart Zone Photocell		

MODEL SZD251CDA PARTS LIST FOR UNDERNEATH DRIVE

Specify **Unit Serial Number** when ordering replacement parts to ensure proper allocation of components (See Ordering Replacement Parts on page 12).
Recommended Spare Parts are shown in red. Charted are item no. and part description
 When ordering use example below.

Example: Need a replacement drive sprocket for a SZD251CDA with Underneath Drive.

Part No: SN 123456 - 27 - Drive Sprocket

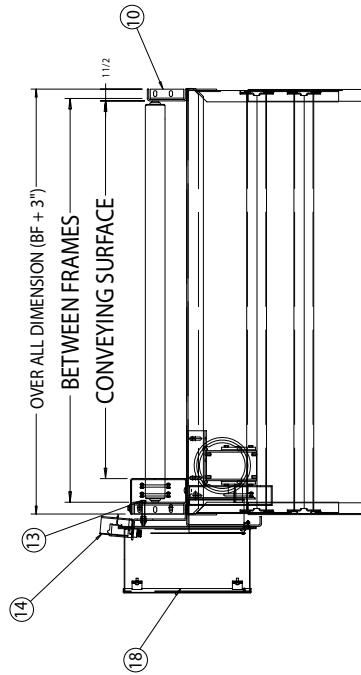

ITEM #	DESCRIPTION	ITEM #	DESCRIPTION
1	SZD251CDA Bed Section	15	Motor Starter Assembly
2	Chain Guard End Cover	16	Enclosure Mounting Bracket
3	Channel Crossmember	17	#40 Chain
4	251S Tread Roller Assembly	18	Power Supply Assembly
5	251S Bed Spacer Roller Assy	19	Power Supply Channel
6	Bottom Chain Guard Top Chain Guard	20	Power Supply Plate
7	7" Drive Side Channel	21	Motorbase Mounting Angle (LH/RH)
8	7" Butt Coupling	22	Reducer Base
9	5" Side Channel	23	Reducer Spacer and Mount
10	5" Butt Coupling	24	Chain Guard
11	Smart Zone Photocell Reflector Tape 2" Long	25	Motor
12	Photoeye Mount	26	Reducer
13	3/8" - 16 x 3" LG. Tap Bolt	27	Drive Sprocket
14	Photoeye Guard	28	Support Assembly

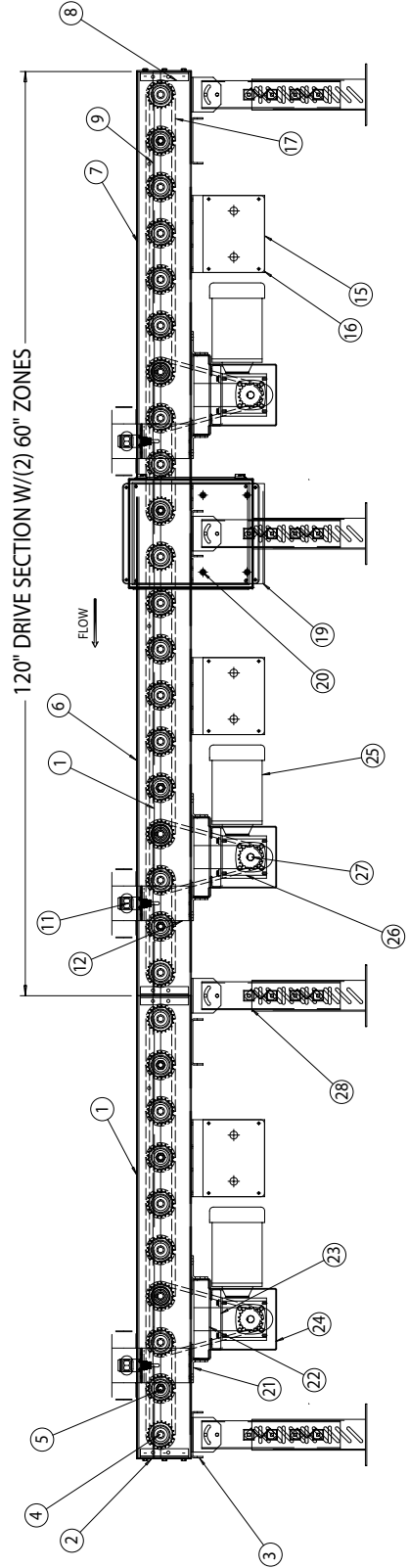



ROACH CONVEYORS

WARRANTY

- Materials used by Roach Conveyors are of good quality.
- Any part proving to be defective in materials or workmanship upon Roach inspection, will be replaced at NO cost, FOB, Trumann, Arkansas, for one year. Installation expense will be paid by others.
- Roach liability includes furnishing said part or parts; Roach is not liable for consequential damages, such as loss of profit, delays or expenses incurred by failure of said part or parts.
- Failure due to abuse, incorrect adjustments, exposure to corrosive or abrasive environment or operation under damp conditions does not constitute failure due to defects in workmanship or materials.
- Component parts not manufactured by Roach (motors, gear reducers, etc.) will be repaired or replaced at the option of their manufacturer. Contact nearest authorized service center for all warranty claims.

NOTE: Motors or gear reducers tampered with before inspection shall be considered free of ALL Warranty Claims.

--All specifications are subject to change without notice--
--Drawings are intended for illustration ONLY and are not to scale--

808 HIGHWAY 463
TRUMANN, ARKANSAS 72472-1310
Tel 870-483-7631 Fax 870-483-7049
info@roachconveyors.com
www.roachconveyors.com



808 HIGHWAY 463
TRUMANN, ARKANSAS 72472-1310
Tel 870-483-7631 Fax 870-483-7049
roachconveyors.com