

Rotary Table

36" and 48" Diameter

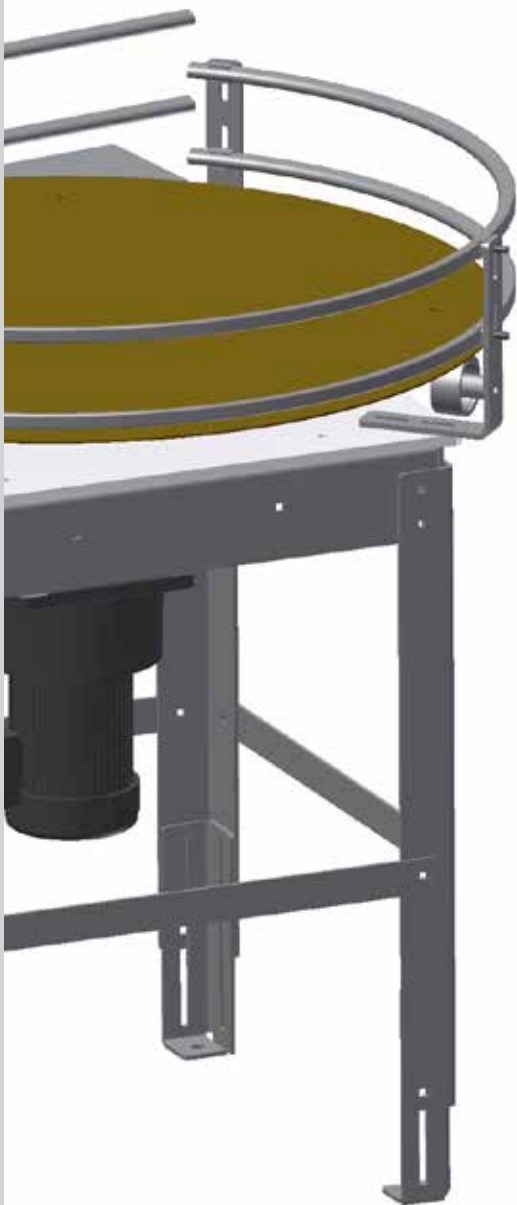

WHY MCE

- > **Heavy-Duty**
- > **Versatile**
- > **Quick & Cost-effective**
- > **Made in the U.S.A.**

ABOUT MCE ROTARY TABLES

Rotary tables, also referred to as accumulation tables or unscrambling tables, are designed to support a variety of conveyor system requirements. They are often used with round containers, such as bottles, to accumulate or unscramble bulk, so that they can be discharged in a single file line.

MODULAR FEATURES

- > Versatility for many product sizes and shapes
- > Clockwise and counter clockwise rotation
- > Adjustable speed control
- > Easy to clean
- > Flexible installation

MCE Rotary Table Standard Technical Features



Rotary tables enable the collation and accumulation of products from conveyor lines and packing areas creating a buffer zone on a low speed line and also providing accumulation at the end of a production line. Ideal for areas that are not large enough or not suitable for an automated system.

- > Ideal for hand packing stations or loading tables
- > Industry-standard spare parts
- > Low maintenance



Rotary Table	Polished Stainless Steel Disc
Support	±4" Adjustment Height
Guide Rail	Flips in Field to Make Either Right or Left Handed
Motor	High Efficiency Washdown-Inverter Duty Gear Motor
Load Capacity	100 lbs Combined Weight

Standard Rotary Table Equipment typically ships in 15-20 business days.

Your local MCE Distributor:

THOMAS CONVEYOR
and Equipment Company, Inc.
15450 Summit Ave • Suite 175 • Oakbrook Terrace, IL 60181
Phone (708) 449-2100 • Fax (708) 449-2106 • www.tceconveyors.com