

# MODEL 254TCDLRC MEDIUM DUTY TAPERED ROLLER CHAIN DRIVEN LIVE ROLLER CURVE

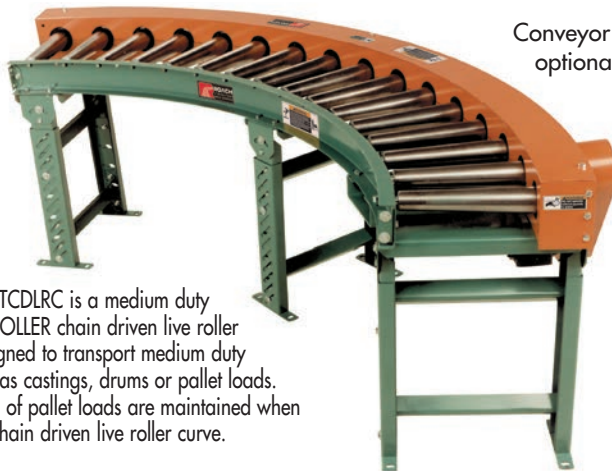

Conveyor shown with optional supports

Model 254TCDLRC is a medium duty TAPERED ROLLER chain driven live roller curve, designed to transport medium duty loads such as castings, drums or pallet loads. Orientation of pallet loads are maintained when using this chain driven live roller curve.

SPECIFY MODEL NUMBER PER EXAMPLE  
254TCDLRC-39-90-R  
254TCDLRC-(between frames)-(degree)-(left or right)

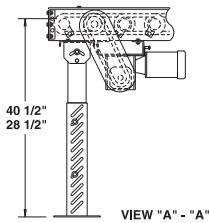
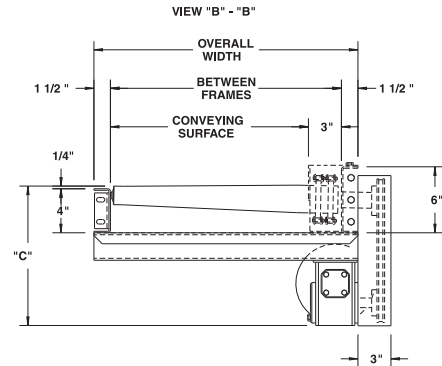

DETERMINING DRIVE LOCATION

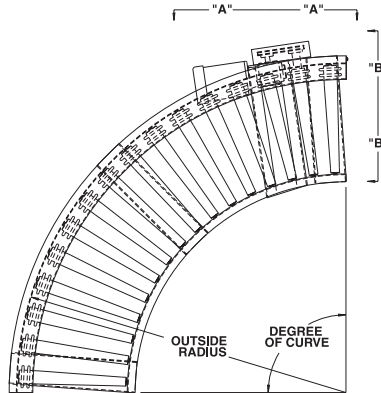
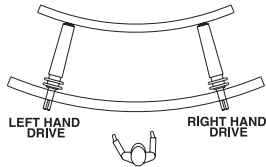

UNIT		90°		45°		
BF	CONV. SURFACE	OUTSIDE RADIUS	QTY. RLRS.	WT (lbs.)	QTY. RLRS.	WT. (lbs.)
15"	12"	5'-2-1/2"	16	344	8	208
21"	18"	5'-2-1/2"	16	372	8	225
27"	24"	5'-2-1/2"	16	403	8	243
33"	30"	7'-9-1/4"	24	447	12	263
39"	36"	7'-9-1/4"	24	486	12	310
45"	42"	7'-9-1/4"	24	528	12	334
51"	48"	7'-9-1/4"	24	559	12	359

## SPECIFICATIONS

TREAD ROLLERS: 2-1/2" dia. to 1-11/16" dia. x 14 ga. steel tapered rollers, model 254T with sprockets.

CHAIN DRIVE: Roller to roller with No. 60 circular roller chain.

END DRIVE: Reversible drive, side mounted or underside (specify). Main drive roller is supported by precision, heavy duty, lubricated, ball bearing units.

ROLLER CENTERS: 6" RC measured at outside radius of curve.

CHAIN GUARD: Chain drive is enclosed, top and bottom, along entire length of conveyor.

BEARINGS: Removable type, heavy duty bearings, zinc plated, grease packed, labyrinth sealed.

MOTOR DRIVE: 3/4 HP, 230/460/3, 60 cycle, ODP right angle gear motor.

BED: 6" x 1-1/2" x 10 ga. and 4" x 1-1/2" x 10 ga. formed steel channel frame.

SPEED: 45 FPM, constant.

DRIVE LOCATION: Drive located on outside of curve. Specify right hand drive or left hand drive (drive hand determined with reference point located at outside of curve).

ELECTRICAL CONTROLS: Optional.

HP @ 45FPM	"C"
1/3, 1/2	13-5/8"
3/4	14"
1	14-1/4"
1-1/2	15-1/8"
2	16"

■ 4 week shipment

## OPTIONAL EQUIPMENT

SPEED: Constant speed 1.5-60 FPM; DC variable speed; AC inverter variable speed. Other constant or variable speeds available.  
NOTE: CAPACITY CHANGES WITH SPEED. 100 FPM MAX. WITH ROLLER-TO-ROLLER CHAIN DRIVE.

MOTORS: Available through 3 HP in TEFC, explosion proof, dirty duty, 115/230/1, 575/3, etc.

FLOOR SUPPORTS: Supports, knee braces, casters, ceiling hangers and polytier supports available. See Conveyor Accessories.

ELECTRICAL CONTROLS: Magnetic or manual starter; limit switch; others available.

**THOMAS CONVEYOR**  
and Equipment Company, Inc.

15450 Summit Ave • Suite 175 • Oakbrook Terrace, IL 60181  
Phone (708) 449-2100 • Fax (708) 449-2106 • www.tceconveyors.com

