

MODEL 738LS LIGHT DUTY LINE SHAFT DRIVEN LIVE ROLLER

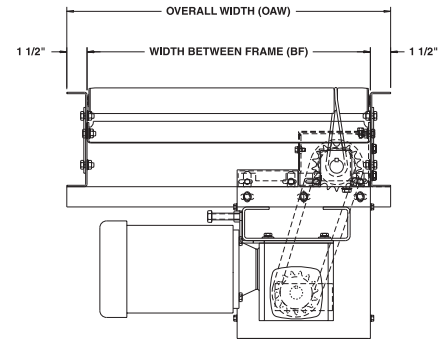

Conveyor shown with optional supports

Model 738LS has gained widespread usage with its unique design. Curves, spurs and a number of accessories may be driven by a SINGLE drive.



	10"	16"	22"
BF	10"	16"	22"
OAW	13"	19"	25"
Length	Unit Weights (lbs.) W/1-1/2" Roller Centers*		
10'	403	502	601
20'	614	776	939
30'	825	1051	1276
40'	1036	1325	1614
50'	1247	1599	1952
60'	1458	1874	2289
70'	1669	2148	2627
80'	1880	2422	2965
90'	2091	2697	3302
100'	2302	2971	3640
Deduct Per Foot	21	27	34

*For other centers, deduct the following (RC/lbs. per ft.):
10" BF--3" RC/4 lbs.; 4" RC/5 lbs.; 6" RC/6 lbs.
16" BF--3" RC/6 lbs.; 4" RC/7.5 lbs.; 6" RC/9 lbs.
22" BF--3" RC/8 lbs.; 4" RC/10 lbs.; 6" RC/12 lbs.

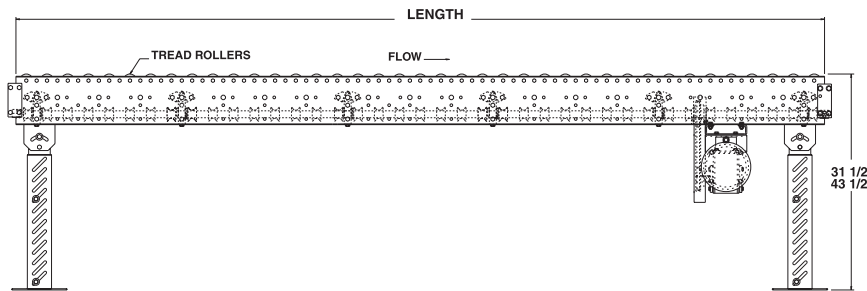

SPECIFICATIONS

TREAD ROLLERS: 1-3/8" dia. x 18 ga. galvanized steel, model 138G w/ 5/16" hex, grooved.

DRIVE BELT: 1/8" dia., polyurethane belts. Nominal 10 lbs. per roller drive.

DRIVE SHAFT: 1" dia. C1018 cold rolled steel shaft.

COUPLINGS: Couplings located both ends (type "A"), one end only (type "B" or "C") or none (type "D"). See 'line shaft coupling chart' on page 74 & specify.

CENTER DRIVE: Reversible drive; located approx. 18" from end of bed section for 3" and 6" RC; 16-1/2" for 4" RC.

BED: 7" x 1-1/2" x 12 ga. formed steel channel frame. Bed sections attached w/ splice plates and floor supports.

SPEED: 60 FPM, constant.

BEARINGS: Precision, lubricated, ball bearing units with composite housings.

MOTOR DRIVE: 1/3 HP, 230/460/3, 60 cycle, ODP right angle gear motor.

ROLLER CHAIN: Drive shaft is driven by No. 50 chain. Chain take-up provided on motor base.

CAPACITY: See Technical Section for load capacity rating.

ELECTRICAL CONTROLS: Optional.

HP@ 60 FPM	"A" MAX
1/3, 1/2	21"
3/4, 1	22"
1-1/2, 2	23"

OPTIONAL EQUIPMENT

SIDE MOUNTED DRIVE: With 10" minimum elevation.

FLOOR SUPPORTS: Supports, knee braces, casters, polytier supports & ceiling hangers available. See Conveyor Accessories.

SPEED: Constant 15-120 FPM, or variable (specify). **MINIMUM** operating speed for line shaft conveyor is 30 FPM. **NOTE: CAPACITY CHANGES WITH SPEED.**

MOTORS: Available through 2 HP in TEFC, explosion proof, dirty duty, 115/230/1, 575/3.

ELECTRICAL CONTROLS: Manual start/stop push button switch; magnetic starter; others available.