

Pneumatic manipulator - Mechspace Pro 70/70P

The easy-to-use balanced manipulator

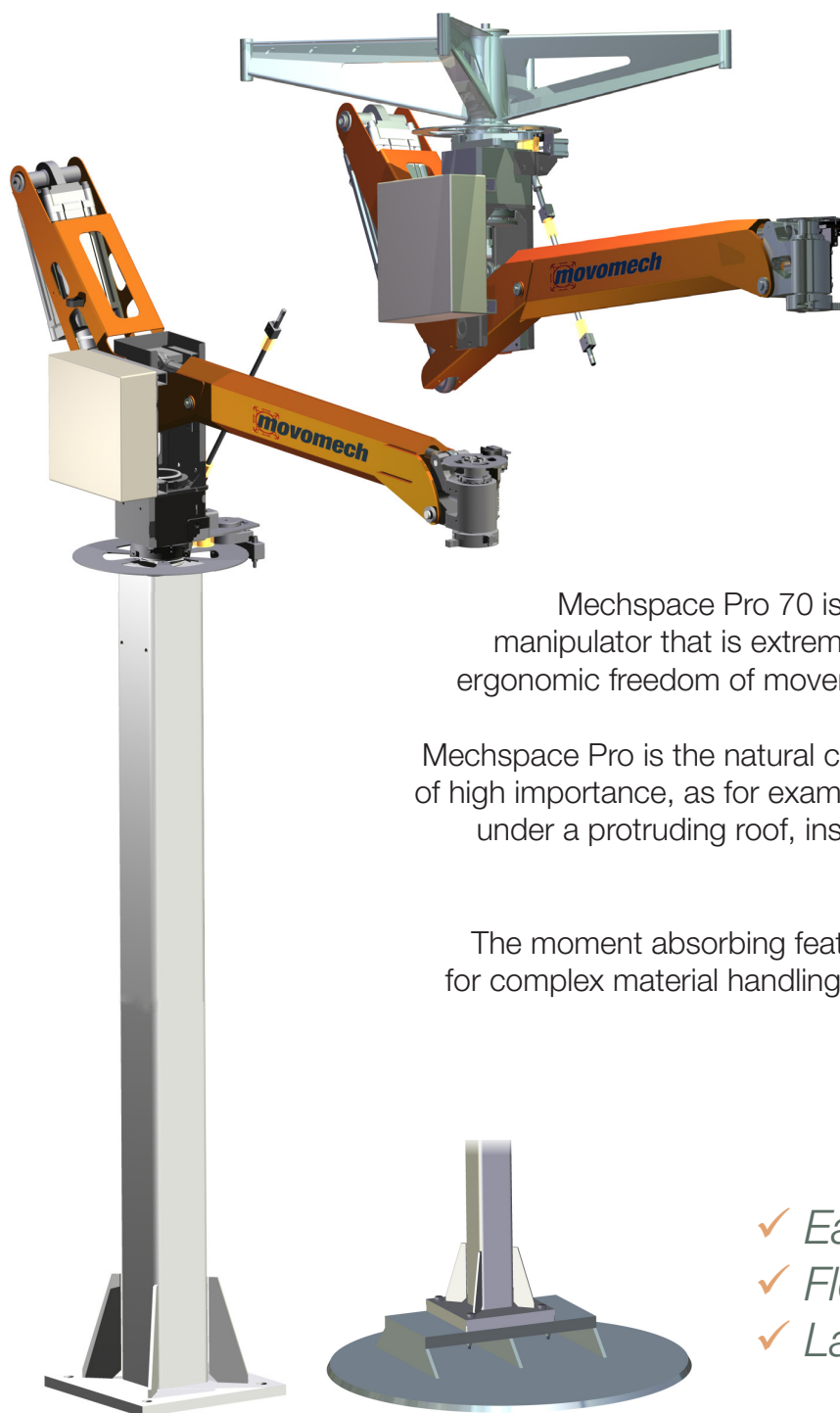

Mechspace Pro 70 is a pneumatic moment absorbing manipulator that is extremely easy to manoeuvre and gives ergonomic freedom of movement within a large working area.

Mechspace Pro is the natural choice where the working reach is of high importance, as for example when the operator is working under a protruding roof, inside a vehicle or in a working area with restricted accessibility.

The moment absorbing features gives important advantages for complex material handling operations, and for gripping and rotation of eccentric loads.

- ✓ *Easy to use*
- ✓ *Flexible*
- ✓ *Large action radius*

Mechspace Pro 70 is available in two models for loads up to 70 kg: a hanging version and a pillarmounted version, which also can be equipped with a mobile footplate for easy repositioning by forklift truck.

The lifter can be delivered balanced for varying loads or with a balance function for two or more permanent loads. The working stroke is 900 mm.



Technical data

Maximum load	kg	50-70 *
Maximum torque	Nm	500
Length of stroke	mm	900
Noise level	db (A)	<70
Maximum tare weight	kg	100 (hanging model)
Hoisting speed	m/min	0-40
Rotation	°	0-330 (upper and lower)
Medium		Air, non-lubricated
Air consumption	l _n /stroke	8 **
Working pressure	bar	4-7
Working temperature	°C	5-40
Colour ***		RAL 2009 (orange), 9010 (white)

* See table below.

** With maximum load.

*** Other colours on demand.

Working pressure [bar]	Load capacity [kg]
4	50
5	60
5,5	65
6	70
7	70

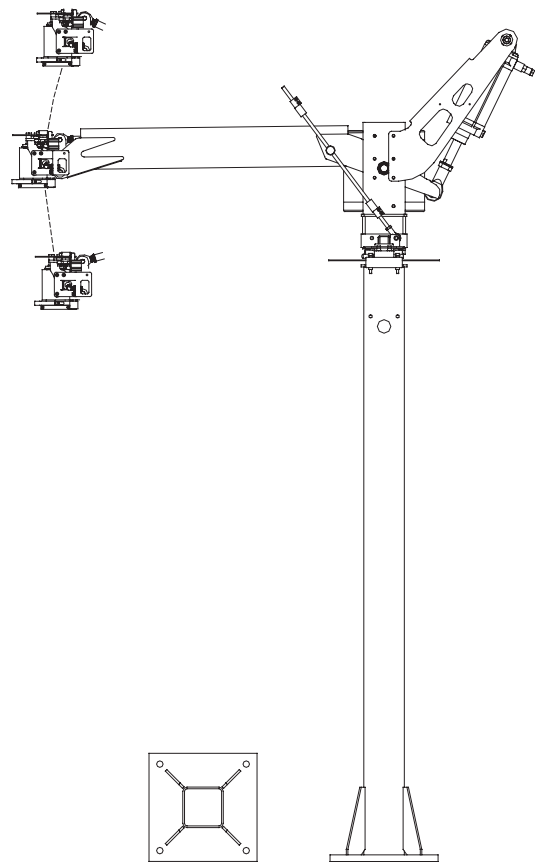
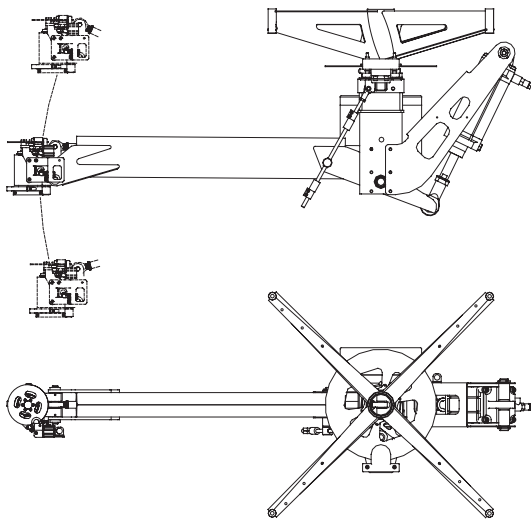

**Thomas
Conveyor &
Equipment Co.**

1S450 Summit Avenue, Suite 175, Oakbrook Terrace IL 60181
844 220 0086 www.tceconveyors.com