

LIFT-O-FLEX



The 19000 Series **LIFT-O-FLEX®** ergonomic lifter offers dynamic load handling characteristics for heavy load capacities. The 19000 series has a lift capacity of 350-lbs and the 19500 provides for a lift capacity of 500-lbs. Both models provide expanded flexibility in equipment selection to better fill your ergonomic lifting requirements.

The 19000 series lifters use many of the same basic lifter components. This allows for inter-changeability between lifters permitting the customer to satisfy ergonomic lifter requirements while maintaining the ability to adapt the lifter to meet the challenge of meeting tomorrow's lifter needs today without incurring the cost of complete replacement.

Features and Benefits:

- Anodized Aluminum Profiles-
 - Intermediate Sections-Standard and Custom lengths
 - Lift Masts
- Steel (Powder Coated Paint-Optional SS)
 - Legs-Bolted to Intermediate
 - Handlebar-Height Adjustable
 - Power Pack Cover
- Standard and custom leg configurations and heights-Swivel and fixed casters-
- Standard and custom length lift masts
- Foot operated 3 position central brake system on rear casters
 - Brake, free wheeling and center lock (trailing)
- Lift mast slip clutch on the down movement provides for safe load handling
- Current limiting (no limit switches) provide for load limiting and stops
- Totally enclosed lift mast w/ball screw for smooth up and down DC powered movement
- Electronic power pack can be provided with either standard or heavy-duty batteries
 - Power packs are also exchangeable allowing for multi-shift operation
- Detachable remote controller
 - Provides the operator with control over load handling functions.
- Handlebar is adjustable by the operators to achieve ergonomic operation

19000/19500 Series Ergonomic Lifter

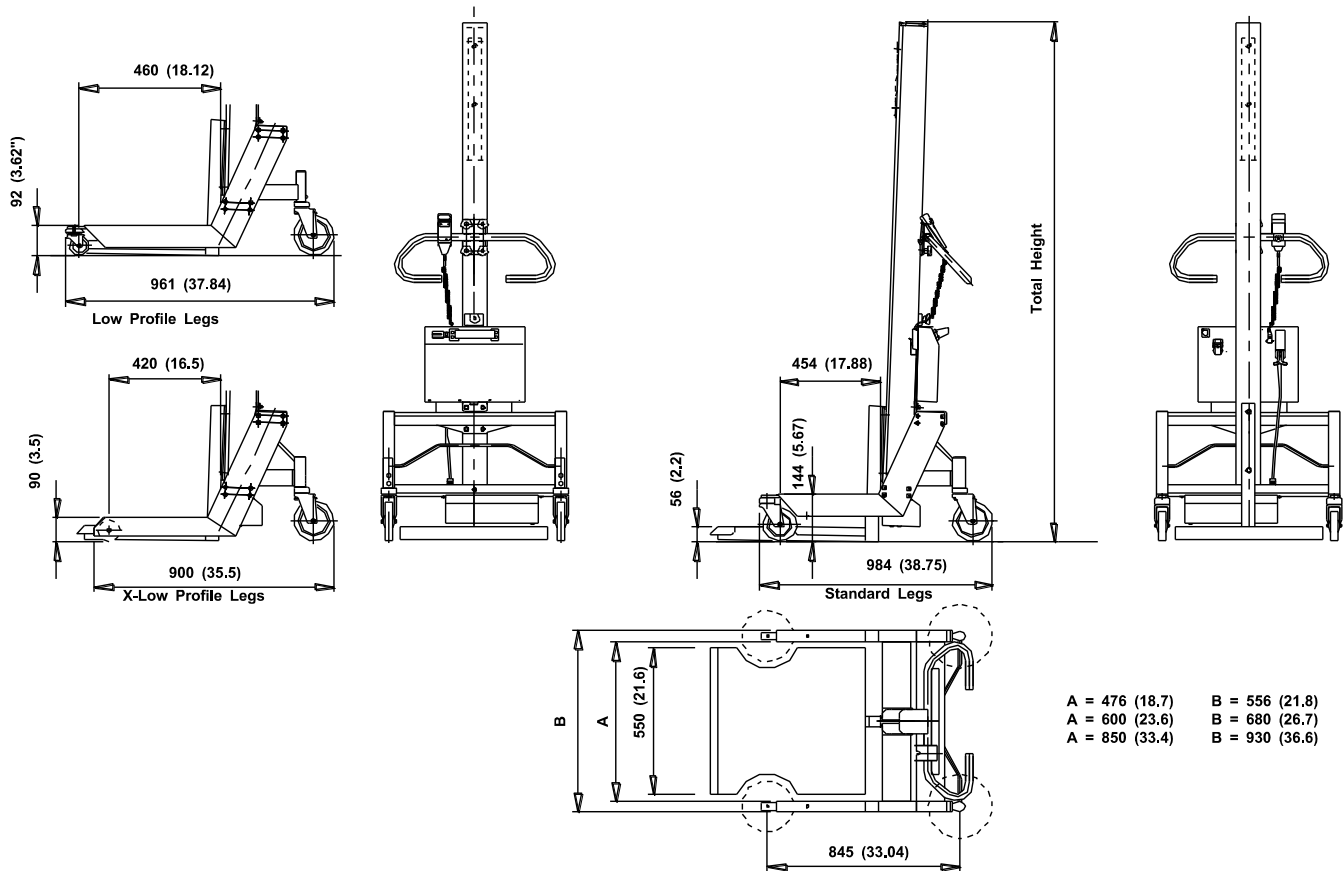

NOTE: Custom Lift-O-Flex® solutions can be designed specifically for your application

Technical Specification 19000/19500 Series Lifters:

Floor to top of Mast Standard Legs	Floor to top of Mast Low Profile Legs	Total Lift Stroke Standard Mast	Total Lift Stroke HD Mast
2003mm (78.8")	1951mm (76.8")	1375mm (54.1")	1262mm (49.7")
2503mm (98.5")	245mm (96.5")	1875mm (73.8")	1694mm (66.7")
3003mm (118.2")	2951mm (116.1")	2368mm (93.2")	2260mm (89")
Minimum Lift Height	~56mm (~2.2")		
Lift-Speed 19000 Series	~100mm/sec (4"/sec)		
Lift-Speed 19500 Series	~50mm/sec (2"/sec)		
Legs-Standard (Overall Length)	Std Length 984mm (38.75")-Long 1184mm (46.62")-X-Long 1384mm (54.5")		
Legs-Low Profile (Overall Length)	Std Length 961mm (37.84")-Long 1161mm (45.72")-X-Long 1361mm (53.6")		
Legs-X-Low Profile (Overall Length)	Std Length 900mm (35.4")-Long 1110mm (39.7")		
Wheel Material	Polyurethane/Rubber		
Wheel Diameter (Front/Back) Standard	100mm (3.9")/150mm (5.9")-Front Single Swivel		
Wheel Diameter (Front/Back) Low built	62mm (2.44")/100mm (3.9")-Front Dual Swivel		
Wheel Diameter (Front/Back) X-Low built	76mm (2.9")/150mm (5.9")-Front Fixed Castor		
Width: Outside	Std-556mm (21.8") Wide 680mm (26.7") X-Wide 858mm (33.4")		
Noise level	>70dB(A)		
Maximum Load 19000 Series	160Kg (350-lbs)		
Maximum Load 19500 Series	225Kg (500-lbs)		
Lifter Weight w/o End-Effector	90Kg (198-lbs)		
Battery Type	Lead Gel Cell		
Battery Voltage	24V, 2 Amp		
Battery Capacity	7.2 AHr		
Recharge Time	6-8 Hours		
Finish	Powder Coated Paint/Anodized or Stainless Steel/Anodized		

Note: Equipment dimensions are subject to change without notice.