



ELEVATE YOUR STANDARDS

GUARDING

DOUBLE-DROP GATE



For Safe Pallet Handling

Designed and manufactured for maximum safety during pallet handling operations. Mezzanine level personnel can access one pallet bay while a forklift operator at the level below is accessing the other. One bay is always open at the mezzanine level for forklift operations.

Interconnected sliding gate operation opens and closes inner and outer protective gates simultaneously providing alternating access to each 5' x 5' bay for uninterrupted loading and unloading cycles.

- ▶ Solid, Quality Construction
- ▶ Easy, Fast Installation
- ▶ Functional, Reliable Design
- ▶ Painted Safety Yellow

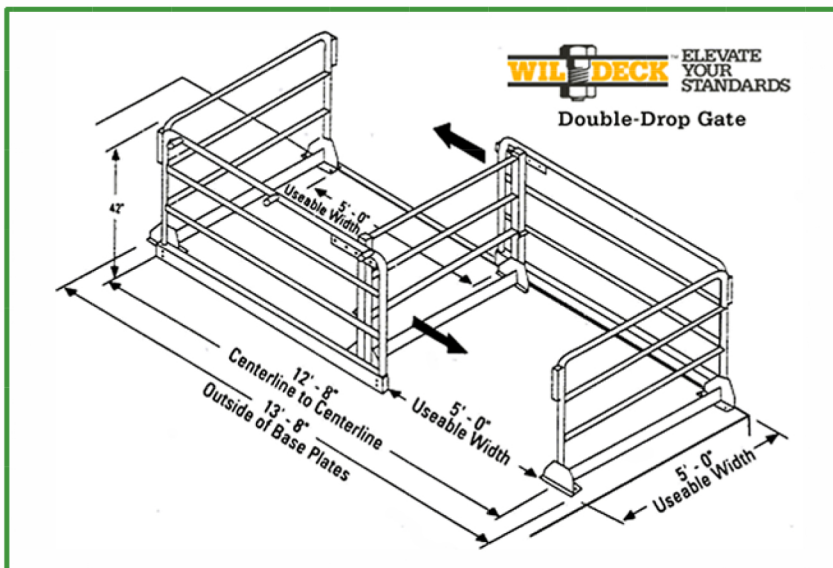

The Wildeck Double-Drop gate system mounts easily to any type of flooring. Three-rail design and construction meets OSHA, BOCA, and UBC requirements.

STORING | LIFTING | GUARDING

Thomas Conveyor & Equipment Co. 1S450 Summit Avenue, Suite 175 Oakbrook Terrace IL 60181
844 220 0086 www.tceconveyors.com conveyors@tceconveyors.com