



Distributed by

**Thomas  
Conveyor &  
Equipment Co.**  
18450 Summit Avenue, Suite 175 Oakbrook Terrace IL 60181  
844.220.0086 [www.tceconveyors.com](http://www.tceconveyors.com) [conveyors@tceconveyors.com](mailto:conveyors@tceconveyors.com)

## FINGER GATE PICK MODULE IMPACT GATE

Wildeck's Finger Gates provide a protective barrier at elevated work levels. The Finger Gate is commonly used for pallet flow and charge areas where pallets are gravity-fed. The spring mechanism allows the gate to be pushed open by a pallet and to self-close as the pallet is unloaded or clears the gate. Wildeck Finger Gates can be freestanding (mounted to deck) or rack-mounted based on the application. The Finger Gate is commonly used for 40" x 48" pallets, however, custom length fingers are easily produced.

### Highlights

- Spring-loaded/self-closing, economical design
- Easily integrates into newly designed or existing rack systems
- Also available as a freestanding unit
- Durable steel makes for a long-lasting safety product
- OSHA, Cal-OSHA, IBC compliant

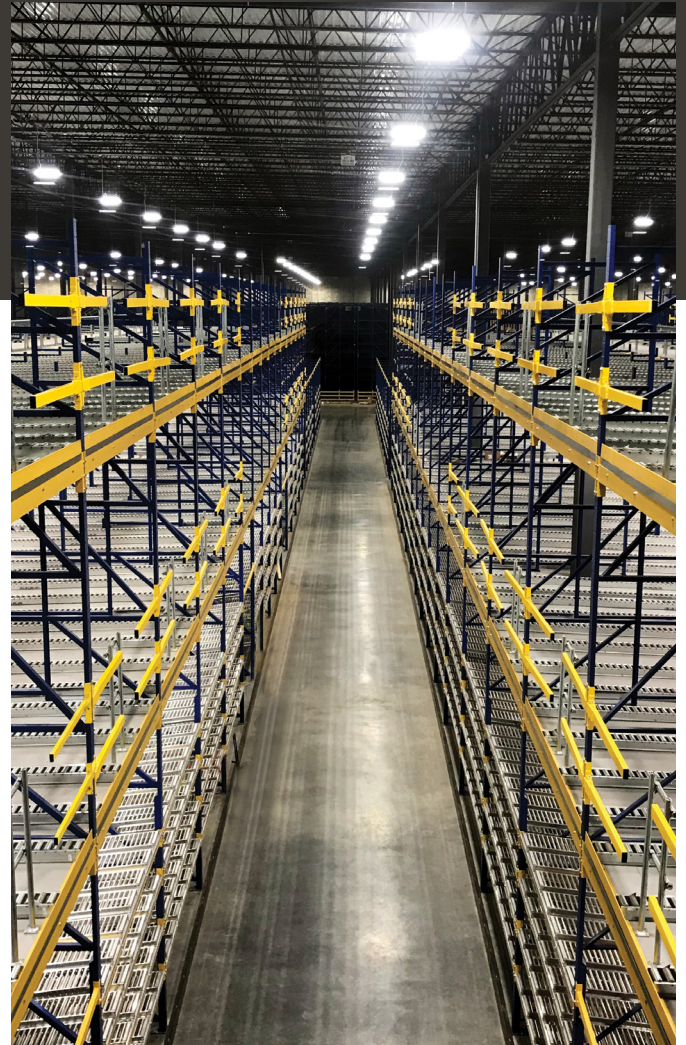

### HOW IT WORKS

Wildeck Finger Gates are easy to install, requiring only two bolts per finger to mount onto existing rack uprights. The Finger Gate's freestanding variations ship with all necessary hardware required for installation. The Finger Gate system can be designed around existing layouts and dropped directly into your CAD files. Wildeck can also integrate protective railing to cover the area between the fingers (*displayed right*), accommodating your walkways between rollers. Both the rack-mounted and the freestanding Finger Gate systems are equipped with spring-loaded hinges, which self-close as palletized materials pass through. These springs have been tested to run over 20,000 cycles without failure.



FINGER GATE

# FINGER GATE PICK MODULE IMPACT GATE



Rack-Mounted Finger Gates easily attach to most rack uprights using two bolts. The holes that mount to the rack are 12" on center.

## STANDARD SPECIFICATIONS

- Mounted to rack uprights to fit common 96" wide bays, or as a freestanding unit shipped with posts; custom sizes exist
- Universal attachment - no left or right sides
- Custom finger lengths available based on your pallet width or width of rack bay
- Optional JiffyRail™ protective railing between fingers to accommodate wider rack bays/walkways between rollers (rail designs are easily configurable; available up to 50" wide)
- Meets OSHA guardrail strength requirements (when closed)
- OSHA Safety Yellow Paint Finish
- Each finger includes 1-1/2" x 3" plastic ribbed end cap
- Bearings in the spring mechanism ensure smooth opening and closing motions
- Springs have been tested to go over 20,000 cycles without failure

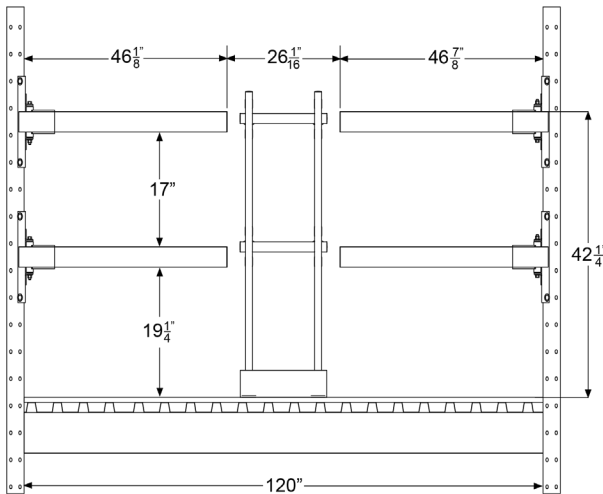

RMLTGATE-48 (Rack-Mounted)

- Rack-Mounted Finger Gate
- Standard model number is designed for common 96" W rack bays; custom sizes available
- Package Includes: Single finger; (4) needed for full bay
- Fingers mount to rack with two bolts per finger (hardware not included due to variations in rack construction)

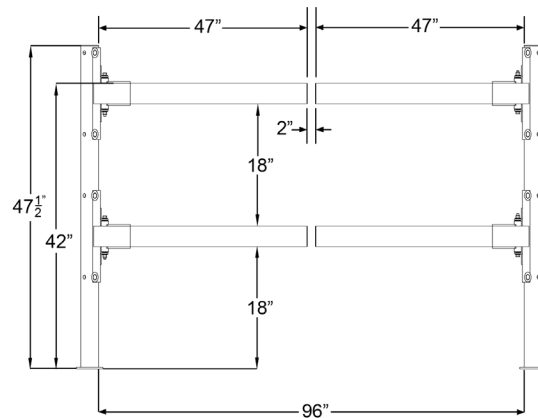

FSLTGATE-48 (Freestanding)

- Freestanding Finger Gate
- Standard model number is designed for 96" W rack bays; custom sizes available
- Package Includes: (4) Fingers and (2) posts; all hardware included
- Posts mount to deck with 1/2" x 3 1/2" bolts (included)
- Fingers mount to post with 1/2" x 4 1/2" bolts (included)