

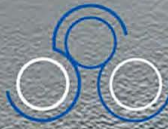

partnered with



**Thomas
Conveyor &
Equipment Co.**



Hinged Steel Belt Conveyors

American Made and American Engineered



15450 Summit Avenue Oakbrook Terrace IL 60181
800 220 0086 www.tceconveyors.com

Hinged Steel Belts Conveyors

Model 715



– Light duty, compact chip conveyor.

Model 722 & 726



– Light duty chip conveyor.

Model 721 & 724

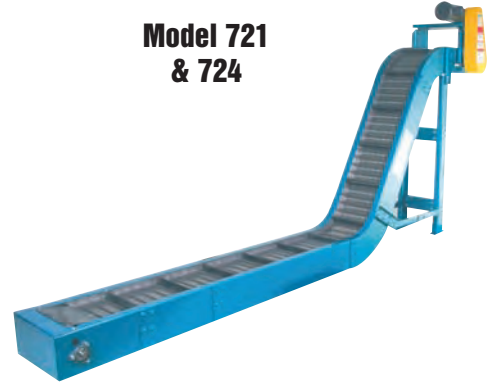

– Standard duty chip conveyor.

Hinged Steel Belt Comparison Chart

Hinged Steel Belt Conveyors – Chip and Scrap Hinged Steel Belt Conveyors — Hinged Steel Belts are designed to carry hot & oily metal parts or scrap. When determining which hinged steel belt model fits your application, pay special attention to the unit's **frame depth and cleat height**. A deeper frame adds the strength needed for longer runs and heavier loads. Deeper frames also provide the room for taller cleats. A taller cleat will move more product than a shorter one. A taller cleat may also be required for steeper inclines (For example, a 1-1/2" high cleat will carry more load up a 60 degree incline than a 5/8" high cleat.) Other unit's lower profile frames are designed to fit into tight spaces.

MODEL	DESCRIPTION	FRAME GAUGE	FRAME DEPTH	DRIVER SIZE	DRIVER TYPE	DRIVE SHAFT DIA.	IDLER SIZE	IDLER TYPE	IDLER SHAFT DIA.	STANDARD CARRIER	STD. DRIVE	OTHER
715	Light duty – 1-1/2" pitch chip conveyor	14	4.125"	10 tooth	4.854 pd	1.1875"	1.375" OD	Hub	.75"	14ga aprons, 5/8" cleats on 12" centers	Top	Frame tapers from 4.125" @ infeed to 6-5/8" @ discharge
720 723	Medium duty chip conveyor Liquid tight M720	12	8.5"	6 tooth	5" pd	1.6875"	6 tooth	5" pd	1.1875"	12ga aprons, 1-3/8" cleats on 12-1/2" centers	Top	720 – Heavy shaft M721 723 – Heavy shaft, liquid tight M721
721 724	Standard duty scrap conveyor Liquid tight M721	12	8.5"	6 tooth	5" pd	1.4375"	6 tooth	5" pd	1.1875"	12ga aprons, 1-3/8" cleats on 12-1/2" centers	Top	Entire frame is 8-1/2" deep – Flat top cleats are 1-1/8" high
722 726	Light duty chip conveyor Liquid tight M722	12	6.625"	5 tooth	4.25" pd	1.1875"	5 tooth	4.25"	1.1875"	12ga aprons, 7/8" cleats on 12-1/2" centers	Top	Entire frame is 6-5/8" deep – Flat top cleats are 5/8" high
725	Low profile infeed chip conveyor	12	5.375"	5 tooth	4.25 pd	1.1875"	1.75" OD	Hub	.75"	12ga aprons, 7/8" cleats on 12-1/2" centers	Top	Frame tapers from 5-3/8" to 6-5/8" – Flat top cleats are 5/8" high
727	Tapered infeed cold header conveyor	12	6.625"	5 tooth	4.25 pd	1.1875"	5 tooth	4.25"	1.1875"	12ga aprons, 5/8" cleats on 12-1/2" centers	Top	Frame tapers from 6-5/8" to 4-1/8" back to 6-5/8"
751 750	4" pitch HSB Hvy drive shaft M751	10 10	15.25" 15.25"	6 tooth 6 tooth	8" pd 8" pd	1.9375" 2.9375"	6 tooth 6 tooth	8" pd 8" pd	1.6875" 1.9375"	7ga aprons, 2-3/8" cleats on 24" centers	Top	M750 Takeup at Infeed M751 Takeup at Drive
760	6" pitch hinged steel belt	Channel	23.25"	6 tooth	12" pd	3.4375"	6 tooth	12" pd	2.9375"	1/4" aprons, 4" cleats on 48" centers	Top	Heavy duty hinged steel belt applications

Model 725

– Low profile infeed chip conveyor.

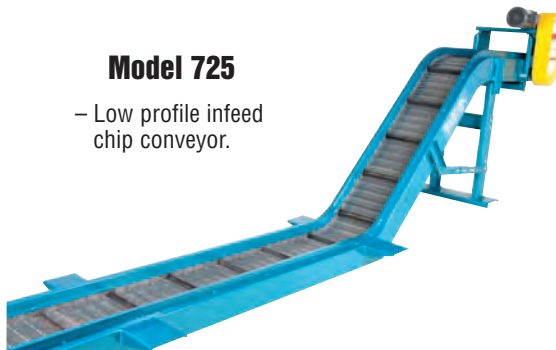

Model 727

– Tapered infeed cold header conveyor.



Model 751 & 750

– Heavy duty chip & scrap conveyor.



Model 760

– Heavy duty scrap and chip conveyor.



Hinged Steel Belt Summary

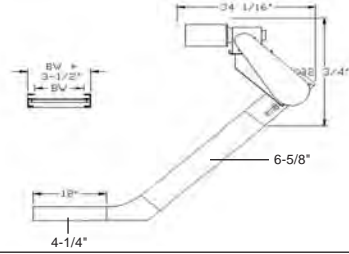

Model 715

Application Summary

- Very low profile
- Very small and lightweight applications

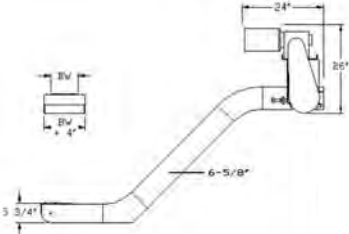

Model 725

Application Summary

- Low profile
- Tight fit lightweight applications

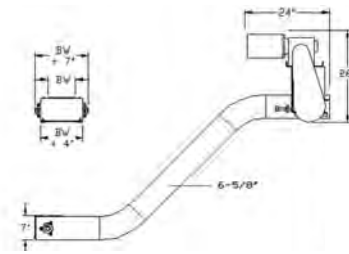

Model 722 & Model 726

Application Summary

- Tight fit applications
- Small scrap conveyor (scrap less than 1/4" x 1/4" conveyor)

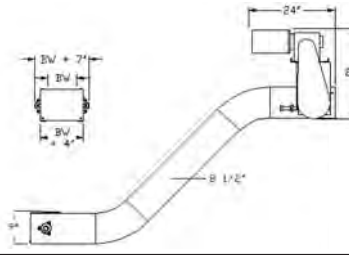

Model 721 & Model 724

Application Summary

- The industry's most economical and dependable scrap conveyor

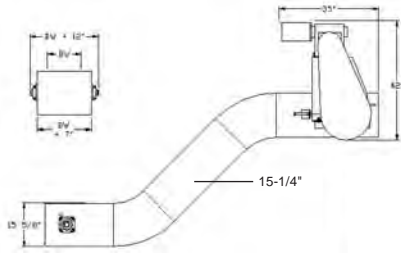

Model 751

Application Summary

- Heavier scrap with high volumes

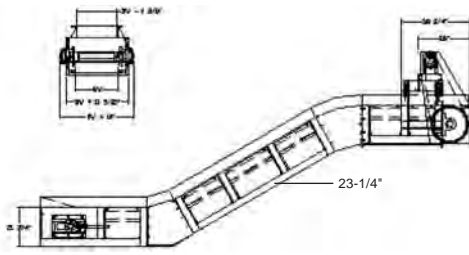

Model 760

Application Summary

- Heavy scrap and high volumes

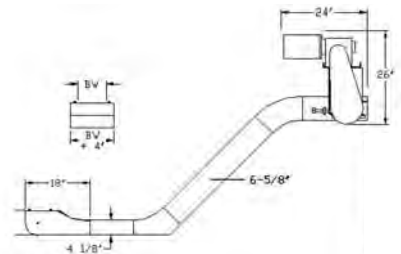

Model 727

Application Summary

- Cold header conveyor
- Designed to fit into an existing machine

STEELTRAK™ Hinged Steel Belt Conveyors

Hinged Steel Belt Conveyors are used to convey virtually any type of metal scrap. These rugged, heavy-duty conveyors are designed for long-term, low-maintenance operations in industrial, scrap, steel chip and fastener applications. They are ideally suited for carrying hot, oily parts from punch presses, forging machines, etc., to drums or hoppers. Various apron, sidewing, siderail and frame designs are available.

SteelTrak™ Model 721



- The industry's most economical and dependable hinged steel belt
- Designed for almost any industrial application

SteelTrak™ Model 722



- Provides SteelTrak™ features when space is limited — 6-5/8" frame vs. 8-1/2"
- Designed for light to medium industrial applications

SteelTrak™ Model 725



- Provides SteelTrak™ features when infeed space is very limited — 5-3/8" infeed
- Designed to fit under existing machines

STEELTRAK™ MODEL	PITCH (PLATE SIZE)	STANDARD CLEATS		FRAME DEPTH	FRAME GAUGE	SIDEWING HEIGHT	STANDARD DRIVE @ 30 FPM
		CONVENTIONAL BELT	FLAT TOP BELT				
Model 715	1-1/2"	5/8" high on 12" centers	N/A	Infeed 4-1/8" Discharge 6-5/8"	10	3/4"	1/2 HP, 3 phase
Model 721	2-1/2"	1-1/2" high on 12-1/2" centers	1-1/8" high on 12-1/2" centers	8-1/2"	12	1-1/2"	1/2 HP, 3 phase
Model 722	2-1/2"	1" high on 12-1/2" centers	5/8" high on 12-1/2" centers	6-5/8"	12	1"	1/2 HP, 3 phase
Model 725	2-1/2"	1" high on 12-1/2" centers	5/8" high on 12-1/2" centers	Infeed 5-3/8" Discharge 6-5/8"	12	1"	1/2 HP, 3 Phase
Model 727	2-1/2"	1" high on 12-1/2" centers	5/8" high on 12-1/2" centers	Tapered infeed 6-5/8" - 4-1/8" Discharge 6-5/8"	12	1"	1/2 HP, 3 Phase
Model 751	4"	10 GA 3" high on 24" centers	7 GA 2-3/8" high on 24" centers	15-1/4"	10	3"	1/2 HP, 3 Phase
Model 760	6"	4" high on 48" centers	N/A	21-3/4"	Struc. Steel	4"	3 HP, 3 phase

SteelTrak™ Model 727



- "Tapered" frame depth (6-5/8" to 4-1/8" to 6-5/8") is designed to fit inside or under an existing machine

SteelTrak™ Model 751



- Designed for medium to heavy industrial applications

SteelTrak™ Model 760



- Designed for heavy industrial applications
- Access panels full length are standard

Metal Handling Support Conveyors

SteelTrak Model 715



SteelTrak Model 715

- This mini pitch (1-1/2" pitch vs. 2-1/2") is ideal for applications with very fine chips and turnings. (See details on back page)

ToughTrak Low Profile Conveyors



ToughTrak Tough & Durable Low Profile Conveyors

- The low profile frame allows for easy placement under an existing machine

MODEL	APPLICATION	FRAME	DRIVE PULLEY DIAMETER / BORE	INFEED PULLEY DIAMETER / BORE	DRIVE-MOTOR	TAKE-UP / TRACKING
Model 150	Standard Duty Low Profile	12 ga x 1-3/4" deep	1-5/16" x 5/8"	1-5/16" x 1/2"	Gearmotor	Internal @ Infeed Internal @ Discharge
Model 250	Heavy Duty Low Profile	12 ga x 1-3/4" deep	2-7/8" x 3/4"	1-5/16" x 1/2"	Motor-Reducer Combination with 56C Frame	Internal @ Infeed External @ Discharge

Note: Cleated belt frame depth = (cleat height + 1/4") + (1-3/4")

Model 700 Magnetic

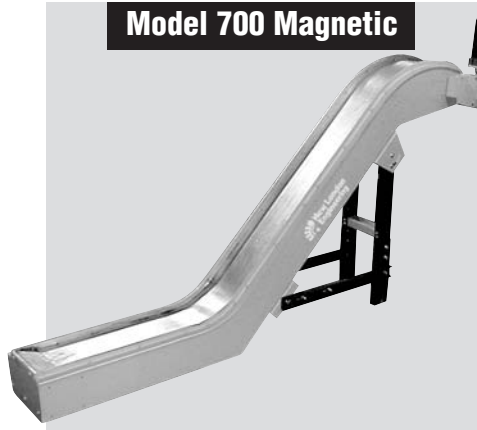

Model 700 Magnetic

- Commonly used to reduce the risk of jamming
- Used in applications involving fasteners, small metals, metallic sludges, submerged metals and sharp-edged scrap

Model 711 Drag

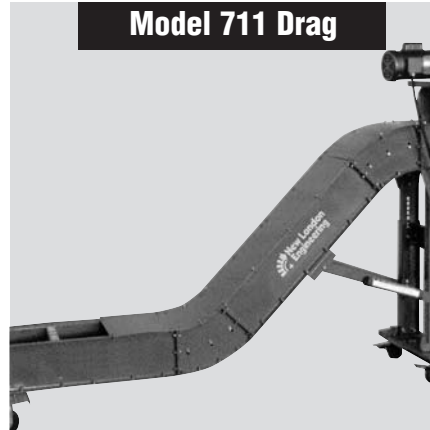

Model 711 Drag

- Commonly used to move small, fine chips and turnings, and fine granulated scrap

MODEL	STANDARD CENTER	FRAME DEPTH	FRAME GAUGE	CURVES	OTHERS
Model 700	12" Center	6-5/8"	12	30, 45, 60	Ceramic magnets – standard duty Neodymium magnets – heavy duty
Model 711	12" Center	8-5/8"	12	30, 45, 60	Unique single chain drag with 1-1/2" high UHMW drag flights

Metal Handling Conveyor Solutions

Hinged Steel Belt Options		
Item #	Option Description	Application
Drive Locations		
1	Top Mount R or L Side	Top mounted Right and Left sides are the standard drive locations.
2	Side Mount R or L Side	Side mounts are used when overhead clearance is limited.
Belt Options		
3	Conventional Top Belts	Standard design — Conventional belt hinge loops are mated together on the top of the belt. This design results in a raised surface at the point where the belt loops are mated. Conventional tops are used in most applications.
4	Flat Top Belts	Flat top belt hinge loops are mated together on the under side of the belt resulting in a smooth or flat belt surface. This flat surface eliminates the pinch point between the hinge loop and the cleats. Flat top belting is often used to convey small objects such as fasteners or screws and in impact applications.
5	Plain Belts	Used for moving almost everything in non-liquid situations.
6	Pimpled Belts	A pimpled surface adds texture to help scrap resist adhesion to the belt. Used primarily in oily applications.
7	Perforated Belts	A 5/32" hole is perforated into the belt so liquids can flow through the belt and drain back to the accumulation tank. Drainage is 20 GPM/sq. ft. of belt of a watery-based liquid.
8	Outside Sidebars	Sidebars are used when more chain pull is necessary. The rated chain pull almost doubles to 3,000# when sidebars are attached. Sidebars are standard for conveyors wider than 24" and longer than 20'.
9	Conventional Sidewings	Sidewings help contain the product on the belt and help prevent side jams.
10	Radial Sidewings	Radial sidewings are used instead of the standard conventional sidewings when jamming of smaller parts may be a problem. Jamming usually occurs in the gap between the wings as the belt is going through a curve. Our exclusive interlocking design virtually eliminates this gap.
11	Keystock over Sidewings	Keystock is a piece of steel welded to the top of the frame. It helps to prevent small or thin scrap from jamming between the top of the sidewings and the frame top.
12	Impact Bars-Bottom Mounted	Impact bars are 3/16 x 9/16 x 1-1/2" channel welded to the bottom of the belt. Used with heavy loads and drops to prevent the belt from buckling and related damage. (Available space permits use in flat top only.)
12	Impact Bars-Top Mounted	Impact bars are 3/16 x 9/16 x 1-1/2" channel welded to the top of the belt. Used with heavy loads and drops to prevent the belt from buckling and to protect the top of the belt.
12	Heat Dissipating Bars	Dissipating bars are channel 3/16 x 9/16 x 1-1/2" bars welded to the top of the belt. These bars help absorb heat and help prevent heat damage to the belt. Recommended when part temperatures are beyond 300°F.
13	Impact Rails	Impact rails are pieces of channel cut the same length as the infeed. They are welded to the frame slightly below the bottom of the belt. Their purpose is to increase belt life by providing additional support to prevent the belt from buckling downward when products are dropped on it.
Not Shown	Sidewing Belt Guides	Belt guides are pieces of steel welded along the frame that act as an additional belt tracking surface. They prolong belt life because the belt runs straighter and smoother. They are typically used when straight sections exceed 20' in total length.
15	Recessed Cleats	Recessed cleats are cut 1" to 2" narrower than the belt width. This gap helps prevent jamming because parts will fall back rather than be pushed to the edge of the cleat where jamming can occur.
15	Cut Back Cleats	Cut back cleats are the same as recessed cleats except that the cuts are at 45 degrees from top to bottom. This angle cut provides a bigger gap between the cleat and the sidewing than a recessed straight cut. This gap helps prevent jamming because parts will fall back rather than be pushed to the edge of the cleat where jamming can occur.
16	Wiper Cleats	These are UHMW plastic cleat extensions bolted to the metal cleat. They are used to clean carryover debris that may accumulate on the bottom pan.
17	Center Lane Dividers	Center lane dividers provide separation between products on the belt when multiple products are conveyed.
Frame Options		
18	Bolt-On Bottom Pan	Bottom pans are bolted to the frame bottom. This design is a safety feature because it closes off access to the return belt. This option is typically used when the conveyor is in an open environment.
19	Top Cover	A top cover is a piece of sheet metal that is bolted to the top of the siderails. Top covers enclose the unit to help contain product that may tumble or bounce off the belt.
20	Chip Suppressor	A chip suppressor is a tube-like unit that is mounted on the front portion of the top cover. Suppressors help prevent spillovers of bulky and stringy material by directing it back under the top cover and back onto the belt.

Metal Handling Conveyor Solutions

Hinged Steel Belt Options		
Item #	Option Description	Application
21	Liquid-Tight Bottom Pan	A liquid-tight bottom pan is a piece of sheet metal that is formed to the frame bottom. Their purpose is to contain fluids within the conveyor so they can be drained into an accumulation tank.
Not Shown	Marine Bearings	Marine bearings are a bronze bushing pressed into the infeed sprockets. Used in liquid-tight applications.
23	Drain Holes	Drain holes provide a means for liquids to flow through the conveyor's bottom pan and into an accumulation tank. (These holes are not plugged.)
24	Fixed Brush at Discharge	Brushes help knock scrap off the apron at discharge to prevent carryover onto the bottom pan.
25	Rounded Infeed	With a rounded infeed, any carryover product rolls off the rounded edge and onto the wiper cleat. Used when total recovery of carryovers is necessary.
26	Access Panels	These are openings cut into the frame's side. They are used for easy access to clean or lubricate the conveyor.
27	Lifting Lugs	Lifting lugs are welded to the conveyor frame. They are used to move the conveyor and/or to aid in installations or removal.
28	Drain Plug	Drain plugs are used to connect a hose to the conveyor to drain or recycle liquids.
29	Take-Up at Infeed	The take-up assembly is designed to take up belt slack due to stretching. A take-up at the infeed is an additional take-up to the one at the discharge. Because longer belts have more stretch slack, this take-up is recommended for units more than 20 feet long.
30	2, 3-1/2, 6 & 12" Flared Rails	Flared siderails are used to contain product and to widen the loading area. The flares also direct the product back to the center of the belt to help prevent jams. 30° and 40° flares are available.
30	Vertical Rails	Vertical siderails are used to contain product. Available in 2, 3-1/2, 6 & 12"
Supports		
31	Supports	New London Engineering will calculate your support needs per application.
32	Knee Braces	Knee braces connect the supports to the frame. They add rigidity and structure to the conveyor. Knee braces are recommended for all units over 36" in elevation and with casters. New London Engineering will calculate your knee brace needs per application.
33	Spreaders	Spreaders help the supports to maintain their intended width or spread.
Casters		
34	3-1/2, 4 & 6"	Rigid, Rigid with Brake, Swivel, Swivel with Brake
35	Outboard Mounted Casters	These casters are mounted to the side of the conveyor rather than the bottom. This format raises the conveyor only 2" off the floor. Used when the infeed clearance is limited.
36	Floor Locks	Floor locks are mounted to the caster brackets. They are used to secure the unit in place during use.
Other Options		
37	Flappers	Flappers help direct products that are dropped on the conveyor away from the infeed and onto the belt.
38	Automatic Chain Oilers	This is a gravity flow lubrication system that is typically mounted at the discharge end. The system is designed to lube the chain and the tracks. Usually used in applications where the product being conveyed is dry and free of liquids.
39	Manual Tube	This is an enclosed tube designed to store your owner's manual safely and conveniently.
	Discharge Chute	Discharge chutes direct the product into the desired location. They are available in either fixed or pivoting positions and in manual or powered configurations.
	Customized Infeed Hopper	Hoppers direct loose material onto the belt. Hoppers are custom made based on each application.
	Quench Tanks	A quench tank is a liquid-tight welded tank usually mounted at the infeed. They are used to submerge parts for cooling or cleaning purposes.
	Special Paint	New London Engineering will match any quick-dry enamel paint chip. For us to match colors exactly, a paint chip must be supplied.
40	Conventional Rollers	These economical rollers are the industry standard.
41	TruTrak Flanged Rollers	TruTrak flanged rollers prevent the belt from rubbing on the frame which virtually eliminates potential wear to the frame, and the belts, axles, sidewings and cotter pins.

Metal Handling Sketch Diagrams

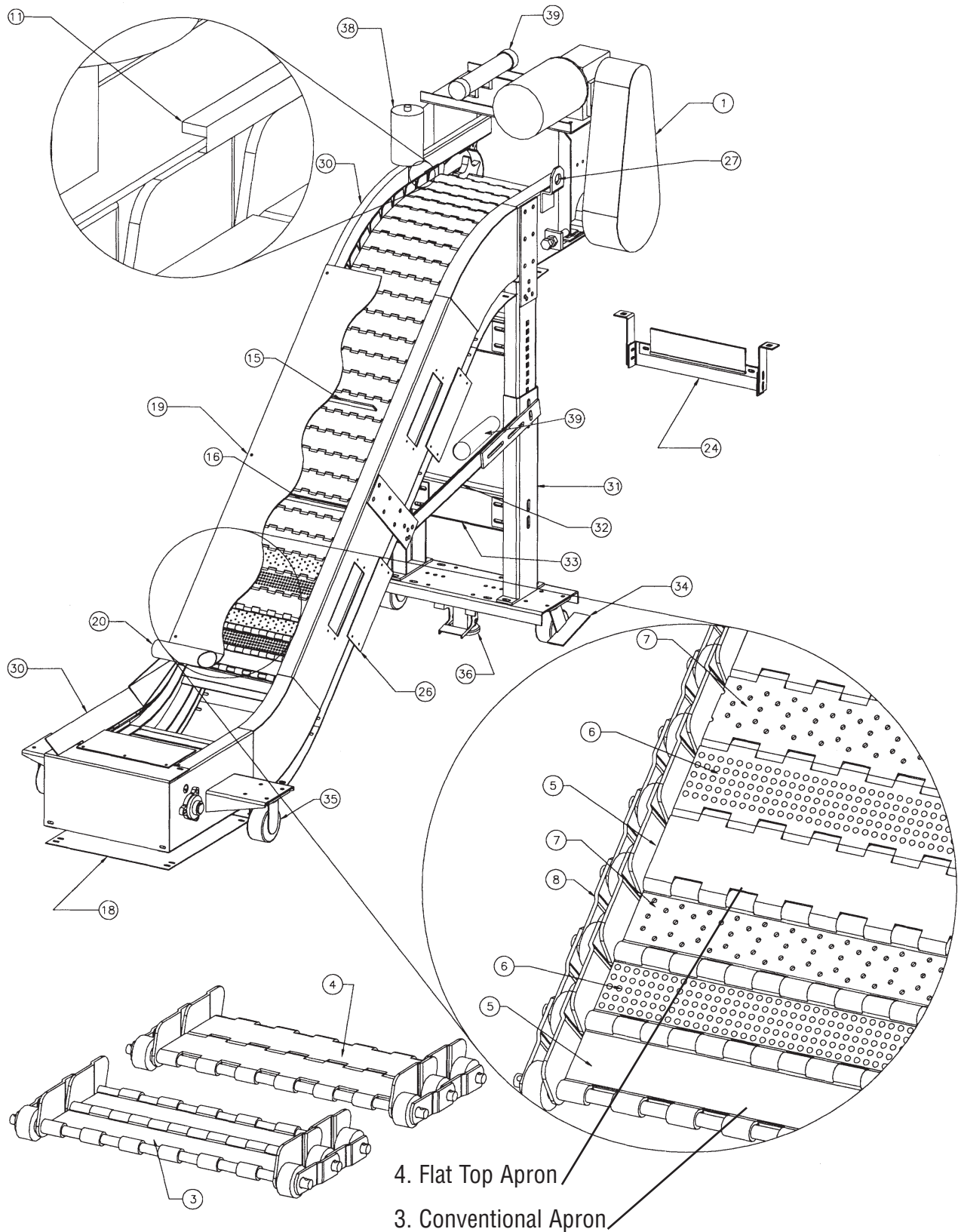

4. Flat Top Apron

3. Conventional Apron

Metal Handling Sketch Diagrams

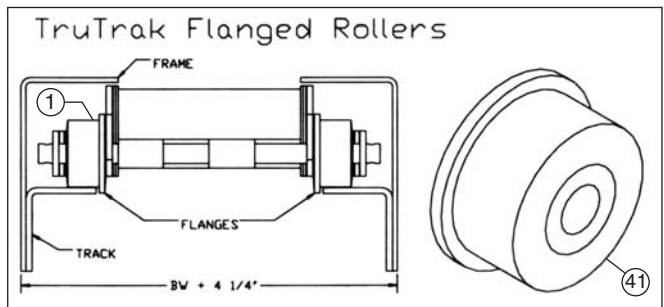
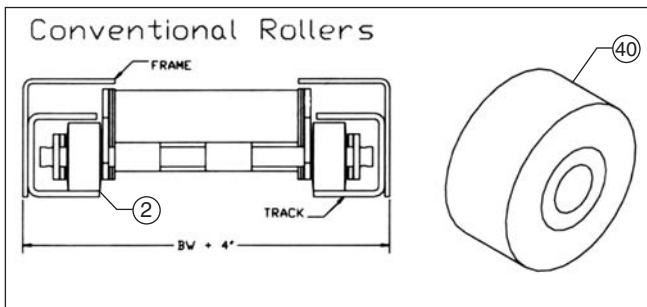
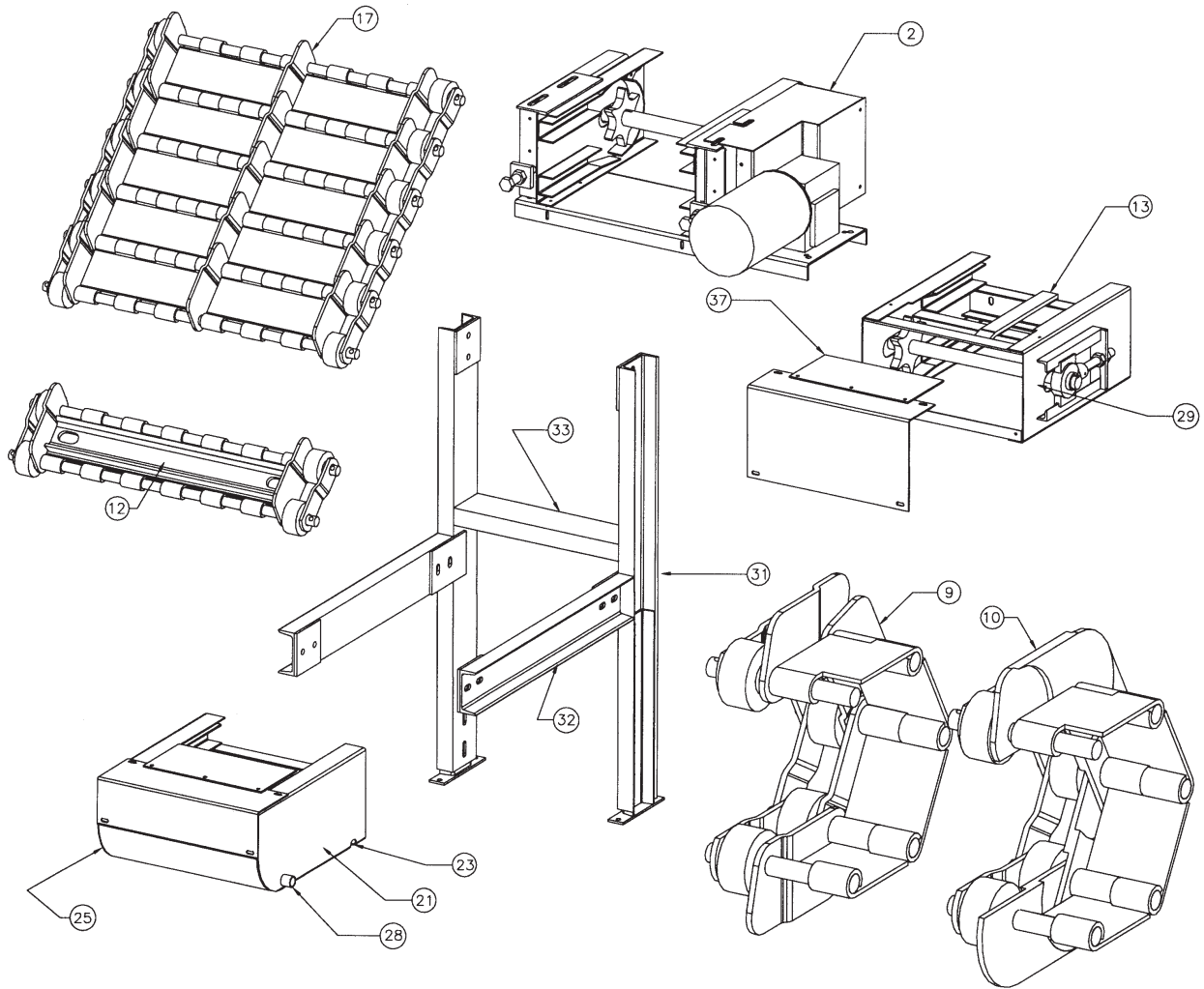

TruTrak rollers are recommended for use in long run, heavy load applications and where prevention of downtime is priority.

Hinged Steel Belt Specifications

Model 721

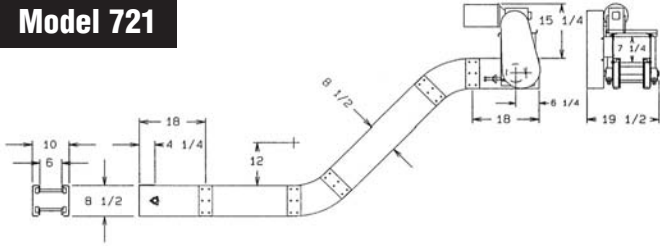

Model 722

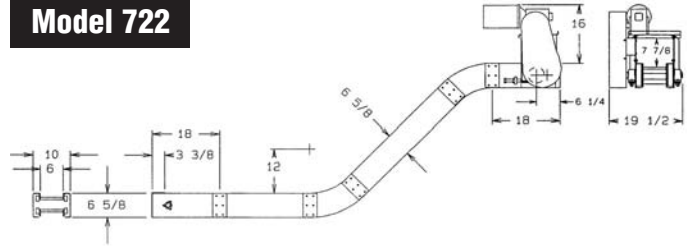

Model 725

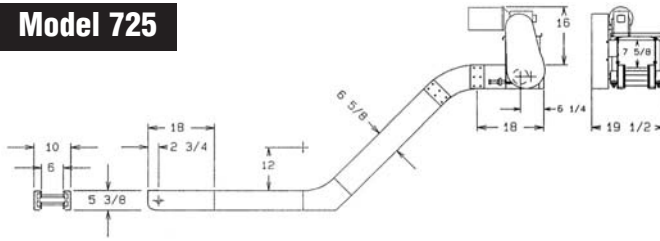

Model 727

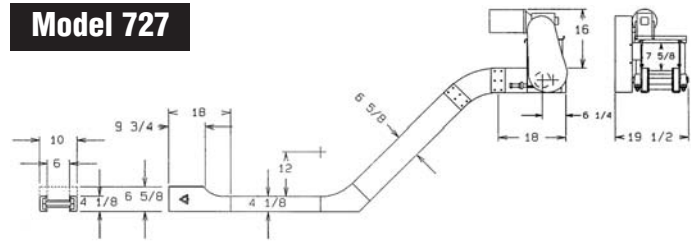

Model 715

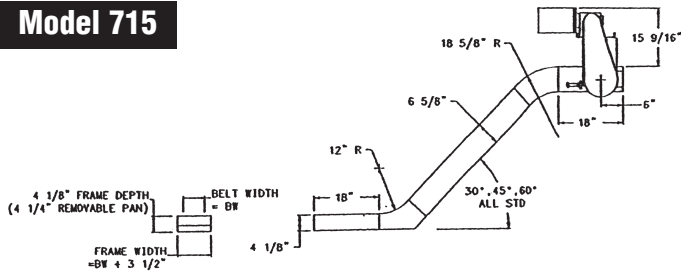

Model 700

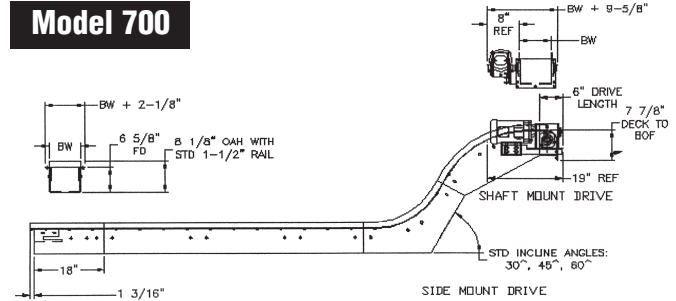

Model 711

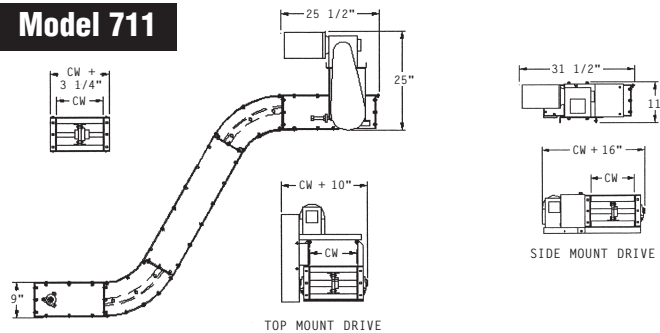

Model 760

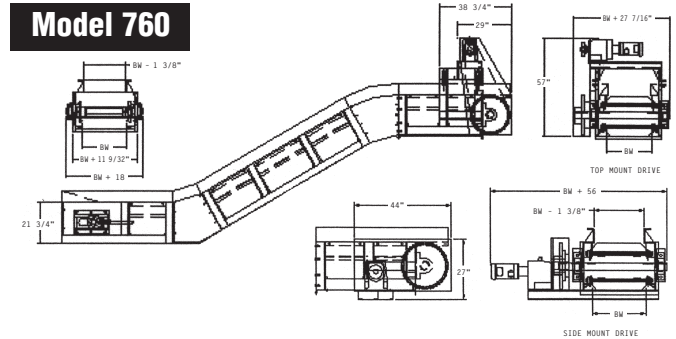

Model 751

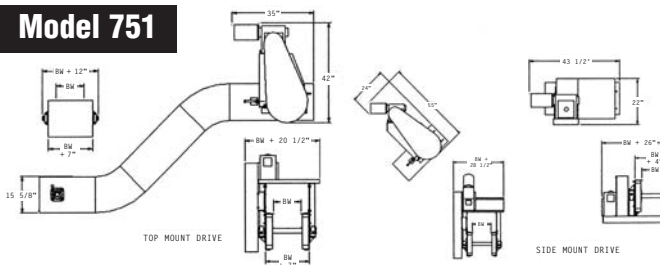

All models are shown with 45° incline. Both 30° and 60° inclines are also available.

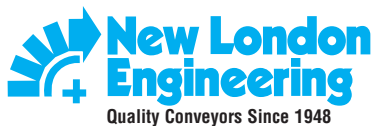

1700 Division Street • New London, WI 54961
800-437-1994 • 920-982-4030 • fax: 920-982-6800 • www.nleco.com