

MISC. ACCESSORIES

PNEUMATIC BRAKE ASSEMBLY



Model PBA pneumatic brake assembly is used to automatically brake rollers for flow control and also for indexing when combined with pneumatic stop. Model above for medium duty applications while model at right designed for heavy duty use. Both shown mounted in optional conveyer.

PNEUMATIC BRAKES MODEL NUMBER
PBAM-24

PBA(medium or heavy duty*)-(brake length)

*Specify M for medium duty or H for heavy duty

SPECIFICATIONS

AIR CYLINDERS: 1/2" stroke.

SOLENOID VALVE: Single, 110 volt.

CONSTRUCTION: 7 ga. formed with 5/16" pad.

LENGTH: 24", 36" and 48" (specify).

OPTIONAL: Double solenoid and electrical controls.

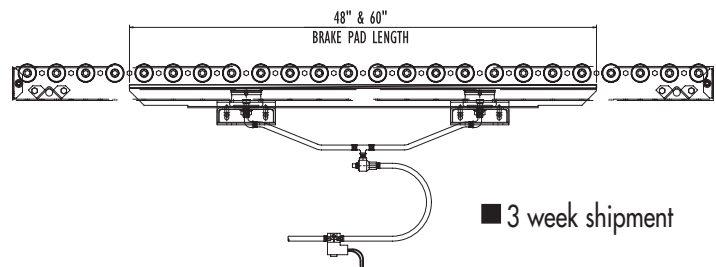
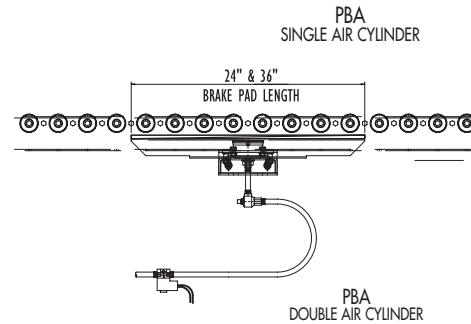

■ 3 week shipment