

MODEL 351TCDLRC HEAVY DUTY TAPERED ROLLER CHAIN DRIVEN LIVE ROLLER CURVE



Conveyor shown with side mounted drive and optional supports

351TCDLRC is a true taper heavy duty chain driven live roller curve. Ideal for conveying pallets or other heavy unit loads, this conveyor features "true taper" to maintain product orientation throughout the curve.

SPECIFY MODEL NUMBER PER EXAMPLE
351TCDLRC-51-90-R
351TCDLRC-(between frames)-(degree)-(left or right)

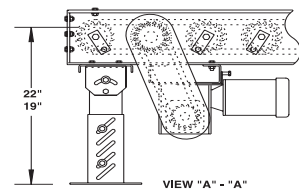
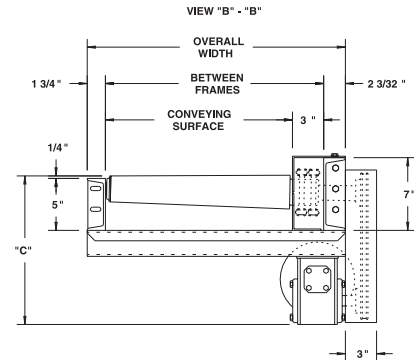

DETERMINING DRIVE LOCATION

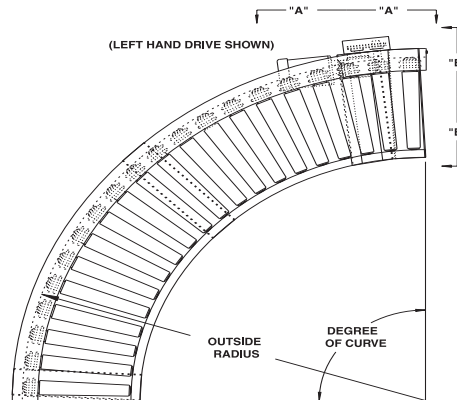
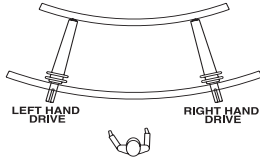

UNIT		90°		45°			
BF	LARGE O.D.	SMALL O.D.	OUTSIDE RADIUS	QTY. RLRs.	WT (lbs.)	QTY. RLRs.	WT (lbs.)
21"	3-1/4"	2-1/2"	6-6"	20	778	10	423
27"	3-1/2"	2-1/2"	7'-1-1/2"	22	966	11	524
33"	3-3/4"	2-1/2"	7'-9-1/4"	24	1192	12	644
39"	4"	2-1/2"	8'-4-3/4"	26	1460	13	787
45"	4-1/4"	2-1/2"	8'-4-3/4"	26	1523	13	801
51"	4-1/2"	2-1/2"	9-1/2"	28	1889	14	990
57"	4-3/4"	2-1/2"	9'8"	30	2307	15	1210
63"	5"	2-1/2"	10-3-3/4"	32	2789	16	1464

SPECIFICATIONS

TREAD ROLLERS: Heavy duty 11 ga. tapered rollers, model 351T with sprockets, for true taper effect. See chart, upper right corner for roller dia.

CHAIN DRIVE: Roller to roller with No. 60 circular roller chain.

END DRIVE: Reversible drive either side mounted or underside (specify). Main drive roller is supported by precision, heavy duty, lubricated, ball bearing units.

ROLLER CENTERS: 6" RC measured at outside radius of curve.

SPEED: 35 FPM, constant.

BED: 5" at 6.7 lbs. and 7" at 9.8 lbs. structural steel channel frame.

BEARINGS: Precision ABEC bearings.

CHAIN GUARD: The chain drive is enclosed, top and bottom, along the entire length of the conveyor.

MOTOR DRIVE: 3/4 HP, 230/460/3, 60 cycle, ODP right angle gear motor.

DRIVE LOCATION: Drive located on outside of curve. Specify right hand drive or left hand drive (drive hand determined with reference point located at outside of curve).

ELECTRICAL CONTROLS: Optional.

HP @ 35FPM	"C"
3/4	15"
1	15-1/4"
1-1/2	16-1/8"
2	17"

OPTIONAL EQUIPMENT

BED: Rollers on 4-1/2" centers on outside radius for 21"-39" BF.

FLOOR SUPPORTS: Supports available. See Conveyor Accessories.

SPEED: Constant speed 1.5-60 FPM; DC variable speed; AC inverter variable speed. Other constant or variable speeds available.

NOTE: CAPACITY CHANGES WITH SPEED. 100 FPM MAX. WITH ROLLER-TO-ROLLER CHAIN DRIVE.

MOTORS: Available through 3 HP in TEFC, explosion proof, dirty duty, 115/230/1, 575/3, etc.