



# BEL 150

SEMI-AUTOMATIC TOP & BOTTOM TAPE CASE SEALER



\*picture shown with optional infeed & outfeed table and casters

*PERFORMANCE DELIVERED*

The BEL 150 is a high quality, semi-automatic tape case sealer designed for the entry level market. This versatile and compact machine can seal a wide range of case sizes and fit in operations with limited floor space. When combined with a BEL case former, it allows one operator to form, pack and seal corrugated cases in a single operation.

A main feature of the BEL 150 is the Uni-Drive System which powers both side belts with a single motor, keeping them synchronized to provide a square seal even after prolonged use. This simple and rugged design will deliver years of reliable and low maintenance performance.

## STANDARD FEATURES

- » Uni-Drive squaring technology that provide consistent and uniform seal on cases
- » Designed and built in North America with premium materials 2 point tool-less case size changeover
- » Simple and quick operation and maintenance
- » Reliable, consistent "no break" tape advance with DEKKA 22 Stainless Steel 2" tape heads

## MACHINE SPECIFICATIONS

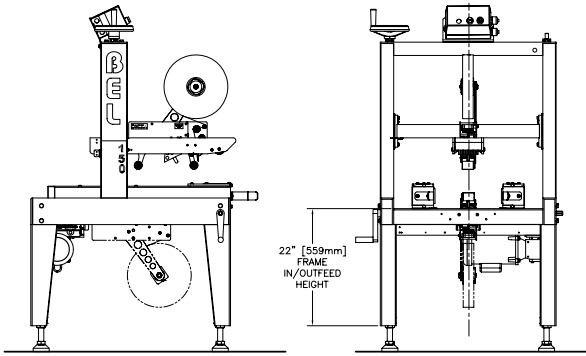

- » Machine Weight: 480 lbs
- » Machine Dimensions: 37.5"(L) x 33"(W) x 60"(H)
- » Electrical: 120 Volts, 1 PH, 60 Hz - 8 amp draw
- » Speeds: up to 30 cases per minute

## OPTIONAL MODIFICATIONS

- » Modifications for undersized or oversized cases
- » Enviroguard water resistant options available
- » Gap Flap or other case style modifications
- » Custom voltages
- » 3" Tape head upgrade

## OPTIONAL ACCESSORIES

- » Locking casters
- » Infeed/outfeed table or conveyor
- » Accumulation table



### Easy Case Size Changes

Tool-less case size changes are simple and quick with change points accessible from both operational sides of the machine.

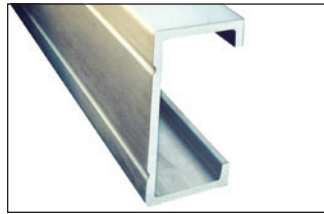

### Lasting Performance

Corrosion resistant and paint free construction guards against machine wear and extends machine life.

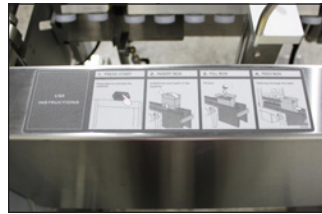

### On Machine Instructions

User-friendly pictorial guides and color coded labelling for convenient operation and size changes.

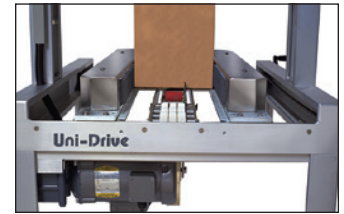

### Repeatability and Reliability

Wexxar/Bel's Uni-Drive System synchronizes both side belts, eliminating case skew, ensuring a square seal even after extended periods of use.

## COMPLETE SOLUTION



### BEL 505 series

Semi-automatic case forming and packing stations folds and holds a case blank in place, providing an efficient and ergonomic solution for hand pack lines.



### Accumulation Table

Ensures product is delivered continuously and ergonomically to the operator. This allows convenient and quick packing as it keeps the product in reach of the operator.



### KDF Box Stand

One of the most popular accessories for semi-automatic packaging lines. The box stand holds case blanks in a convenient position for quick and ergonomic packing.

## CASE SIZE RANGE

	Length	Width	Height
Minimum	8" 203 mm	5" 127 mm	4 1/2" 114 mm
Maximum	unlimited	18" 457 mm	21" 533 mm

### Infeed/Outfeed Height (with adjustable foot pads)

*Note: Casters add 4" to minimum and maximum height*

Minimum	25" (635mm)
Maximum	32" (813mm)

Machine Speed: Up to 30 cases per minute.  
Oversize model available. Consult factory for case size ranges.

*Specifications are subject to change without notice.*



1S450 Summit Avenue, Suite 175, Oakbrook Terrace IL 60181  
Ph. 844 220 0086  
www.tceconveyors.com  
conveyors@tceconveyors.com