



 **WEXXAR BEL®**

BEL 252

FULLY AUTOMATIC TOP & BOTTOM TAPE CASE SEALER

EoL

**END OF
LINE**

BEL 252

FULLY AUTOMATIC TOP & BOTTOM TAPE CASE SEALER

BEL 252 INCREASES SAFETY AND ACCESSIBILITY

Case Sealing with the BEL 252's ultra-safe Snap Folders allows for quick and easy maintenance and case clearing.

Delivers Reliable And Low Maintenance Performance

The BEL 252 is a revolutionary fully automatic tape case sealer featuring Wexxar Bel's Snap Folder technology. This ultra-safe design allows the machine to be versatile and compact without the need for excessive guarding. This allows the machine to fit in operations with limited floor space and also keeps the machine easy to access and maintain. When combined with a Wexxar Bel case former, it creates a complete case forming and sealing packaging line.

A main feature of the BEL 252 is the Uni-Drive System which powers both side belts with a single motor, keeping them synchronized to provide a square seal even after prolonged use. This simple and rugged design will deliver years of reliable and low maintenance performance.



ABOUT THE BEL 252



EASY CASE SIZE CHANGES

Tool less case size changes are simple and quick with change points accessible from both operational sides of the machine.

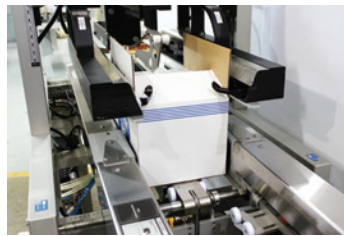

ULTRA-SAFE FLAP FOLDING

Wexxar Bel's Snap Folder keeps operators safe while freeing the machine from guarding, reducing the machine footprint and allowing for easy maintenance.



ON MACHINE INSTRUCTIONS

User-friendly pictorial guides and color-coded labeling for convenient operation and size changes.

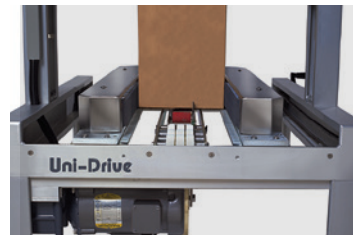

REPEATABILITY AND RELIABILITY

Wexxar Bel's Uni-Drive system synchronizes both side belts, eliminating case skew, ensuring a square seal even after extended periods of use.

COMPLETE SOLUTION

FULLY AUTOMATE YOUR PACKAGING LINE WITH THESE FORMING AND PACKING SOLUTIONS.



BEL 505 SERIES CASE FORMER

Semi-automatic case forming and packing stations provide an efficient and ergonomic solution for hand pack lines. The machine folds and holds the case in place for the user to pack with both hands.



WF20 AUTOMATIC CASE ERECTOR

Fully automatic tape or hot melt case erector with Wexxar Bel's patented Pin & Dome technology for reliable and consistent case forming.



PRODUCT AND CASE DELIVERY CONVEYORS

Modular product and case delivery conveyors which can be customized with multiple packing stations for convenient case forming, packing and sealing.

For more information, visit www.TCEconveyors.com

CONFIGURATION

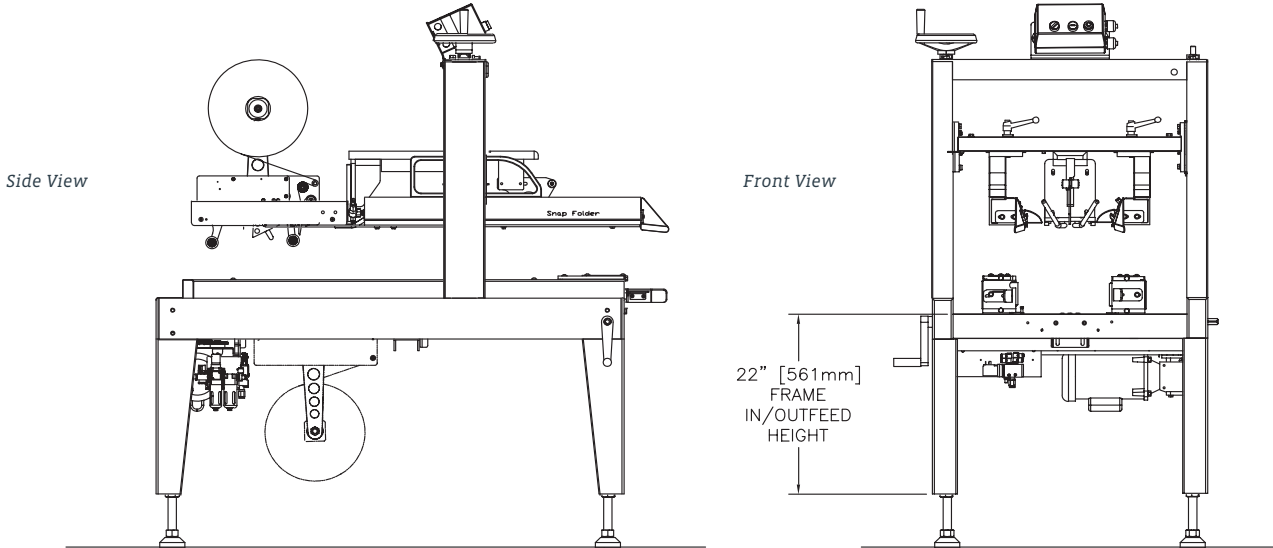

STANDARD FEATURES

- Snap Folder ultra-safe design folds flaps without the use of dangerous flap kickers
- Uni-Drive squaring technology that provide consistent and uniform seal on cases
- Paint-free finish guards provides a clean finish and protection against contamination and the environment
- Magnetic motor start prevents accidental restarts and protects the motor from power overload
- Easy and minimal maintenance including quick tape head and belt changes
- Reliable, consistent "no break" tape advance with Dekka SE-22 stainless steel 2" tape head

OPTIONAL MODIFICATIONS

- Modifications for undersized or oversized cases
- Custom voltages
- Enviroguard water resistant options available
- 3" Tape head upgrade

OPTIONAL ACCESSORIES

- Locking Casters
- Indexing Stop Gates
- Infeed/Outfeed Table or Conveyor
- Digital Dial Indicators

PRODUCT SPECIFICATIONS

Machine Weight	650 lbs
Machine Dimensions	56"(L) x 33"(W) x 60"(H)
Air	0.13 cubic feet per cycle at 90 p.s.i.
Electrical	120 Volts, 1PH, 60 Hz - 8amp draw
Speeds	up to 25 cases per minute

Specifications are subject to change without notice.

CASE SIZE RANGE

	LENGTH	WIDTH	HEIGHT
Minimum	8" 203 mm	6" 152 mm	5" 127 mm
Maximum	22" 559 mm	15 1/2" 394 mm	16" 406 mm

Oversize model available. Consult factory for case size ranges.

INFEED/OUTFEED HEIGHT

Minimum	25" (635 mm)
Maximum	32" (813 mm)

Note: Casters add 4" to minimum and maximum height



PROMACH[®]



WEXXAR BEL

At Wexxar Bel, corrugated container packaging applications are limited only by the imagination. Our Wexxar case formers and case sealers have been installed in nearly 40 countries and consistently bring customers the lowest cost of ownership and the highest standards of safety. Wexxar also offers the BEL line of corrugated box sealers, tapers, and packing systems as well as the IPAK line of tray and bliss formers, stackers, and sealers systems. As part of the ProMach End of Line business line, Wexxar helps our packaging customers protect and grow the reputation and trust of their consumers. ProMach is performance, and the proof is in every package.

Distributed by



**Thomas
Conveyor &
Equipment Co.**



**Thomas
Conveyor &
Equipment Co.**

1S450 Summit Avenue, Suite 175
Oakbrook Terrace IL 60181
Ph. 844 220 0086
www.tceconveyors.com
conveyors@tceconveyors.com